

EM 23

**Modern dairy farming in warm climate
zones**

Volume 3

Bart Gietema

© Agromisa Foundation, Wageningen, 2005.

All rights reserved. No part of this book may be reproduced in any form, by print, photocopy, microfilm or any other means, without written permission from the publisher.

First edition: 2005

Author: Bart Gietema

ISBN: 90 5285 015 1 / 016 X
NUGI: 835

Foreword

The text of this volume of Modern Dairy Farming in Warm Climate Zones is a revision of an earlier text.

The (very important) financial-economic aspects of dairy farming are not covered in this text. They are dealt with in the AGROMISA guides 'The Farm as a Commercial Enterprise' (110 pages, with exercises and answers; 2003) and 'Farm Accounting' (50 pages; 2003).

IJhorst, NL
January 2004

B.Gietema
compilation, editing and layout
E-mail: b-n.gietema@hetnet.nl

Contents

| | | |
|----------|---|-----------|
| 1 | Health and disease of cows | 5 |
| 1.1 | Disease | 5 |
| 1.2 | Signs indicating whether a cow is healthy or ill | 5 |
| 2 | Causes of diseases affecting cows disease immunity | 7 |
| 2.1 | Parasites | 7 |
| 2.2 | Bacteria | 8 |
| 2.3 | Immunity and vaccination | 9 |
| 3 | Endo + ectoparasites of cattle | 12 |
| 3.1 | Endoparasites | 12 |
| 3.2 | Ectoparasites | 16 |
| 4 | Some important diseases which may affect dairy cattle | 18 |
| 4.1 | Diseases due to deficiencies, toxic substances and metabolic disorders | 18 |
| 4.2 | Viral Infections | 20 |
| 4.3 | Bacterial Infections | 22 |
| 4.4 | Tick-borne diseases | 25 |
| 4.5 | Fungal Diseases | 26 |
| 5 | Calf rearing | 30 |
| 5.1 | Introduction | 30 |
| 5.2 | Calving | 30 |
| 5.3 | Feedstuffs | 31 |
| 5.4 | Calf rearing methods | 33 |
| 5.5 | Calf diseases | 35 |
| 5.6 | Housing | 37 |
| 5.7 | Grazing | 38 |
| 5.8 | Special treatments during the rearing period | 38 |
| 5.9 | Results of good calf rearing | 39 |
| 6 | Herd administration | 41 |
| 6.1 | Cow identification | 41 |
| 6.2 | Farm records | 42 |
| 6.3 | Office records | 43 |
| 7 | Housing of dairy cattle | 45 |
| 7.1 | The climate | 45 |
| 7.2 | Introduction to the housing of dairy cattle | 47 |
| 7.3 | Housing systems | 48 |
| 7.4 | Health facilities | 54 |
| 7.5 | Housing for young stock | 55 |
| 7.6 | Environmental structures | 56 |
| 8 | Suggested practicals in dairy farming training | 62 |
| 8.1 | List of topics for practicals in dairy farming training within regular teaching hours | 62 |
| 8.2 | Suggestions for learning activities outside regular teaching hours | 68 |

1 Health and disease of cows

1.1 Disease

It is not easy to say what 'disease' means. In a general sense it means anything which is not 'normal' with an animal (our cow). However, it is more accurate to say that 'disease' is a condition brought about in a living organism which is detrimental to the health and well-being of that living organism. In the general sense the term 'disease' also includes injuries, nutritional deficiencies, poisoning and hereditary abnormalities.

'Health' is the opposite condition; it is the maintenance of a state of well-being and normal functioning of all the processes taking place in the animal body.

The presence of disease (acute or chronic) reduces production and therefore always causes financial loss to the farmer.

Good health care in the dairy herd with correct feeding, housing and milking, general hygiene and vaccination programmes, is of great importance for optimal technical and financial farming results.

1.2 Signs indicating whether a cow is healthy or ill

The extent to which cows (and farm animals in general) are healthy or ill can be deduced by looking at a number of things, namely:

Nutritional status

The nutritional status can be judged by looking at a cow. The cow can be fat, normal or thin.

A skinny cow is not necessarily a sick cow; for instance, it is normal for recently calved, high production cows, to lose some body weight and become a bit thin.

Therefore, the condition of a cow should be judged in relation to other circumstances, such as how much feed is available, in which lactation stage the cow is, the breed of the cow, etc..

Sick cows tend to lose weight, sometimes very rapidly.

This is because the appetite of the cow decreases, the digestive processes are affected and, if the cow has a fever, the body draws heavily on its reserves.

Way of walking and standing

The way a cow walks and stands can be abnormal because of a pain somewhere in the body.

A clear example is when a hoof of a cow is infected. In this case the cow will often be seen limping.

Eyes

A cow's eyes should have a lively expression. The ears also can give an indication about health (ear movement, ear play).

Skin, coat and mucous membranes

The skin of a healthy cow is flexible, easy to crease (fold), and quick to unfold with disappearing creases.

When the skin is pinched and the fold does not disappear, the cow is dehydrated. This happens in calves with serious scours.

The coat should be smooth and shiny. In cases of anaemia, parasitic infections and deficiencies, the coat becomes rough and dry, and does not have a shiny appearance.

The mucous membranes of the eyelids, nose and vagina should have a pink to reddish colour and should be moist. When a cow is sick, the membranes become either too red or too pale (anaemia).

Digestion

Healthy cows have a good appetite and eat with eagerness. Faeces and urine are discharged regularly and the faeces have a normal consistency. Dairy cows normally defecate 12-18 times a day and produce 20-40 kg faeces. When digestion is disturbed, the cow's appetite decreases and the faeces are discharged too fast (scours) or too slow (constipation).

Ruminants ruminate frequently when healthy. When a cow is not seen ruminating when resting, this indicates that her digestion is disturbed. In this case rumen motility (movements in her rumen) has come to a stop.

Rumen motility can be felt by pushing a fist into the left upper flank of the cow. In healthy cows the rumen can be felt moving about three times per two minutes.

Ruminating is done 6-8 hours per 24 hours and each feed lump is ruminated 40-60 times.

Respiration

In healthy cows respiration is quiet and regular. In cases of unrest, fever, hard labour, fatigue, high environmental temperatures or high humidity, the respiration rate (= number of respirations/minute) increases.

The respiration rate of a cow is 10-30, a calf around 30, a horse 8-12 and a sheep 10-20.

Blood circulation

The compression of the ventricle of the heart enables the blood to pass through the arteries. The compression of the heart can be felt by putting a hand on the heart area, just behind the left elbow.

The heart beat can also be checked by measuring the cow's pulse rate (= number of pulsations per minute).

The pulse of a cow can be felt by pressing softly with the forefinger and middlefinger on an artery at a place where the artery comes close to the surface; that is under the lower jaw close against the chewing muscle or under the tail head.

Calves have a pulse rate of about 100, horses 28-40, cows 60-70 and sheep 60-90. Fever, hard labour, unrest and excitement can make the pulse rate increase.

Body temperature

The normal body temperatures of some farm animals are:

- cow 38.0-39.5 °C
- horse 37.4-38.0
- calf 39.5-40.0
- sheep 38.0-39.5

The animal body has different means of keeping its temperature within the normal range.

In a cold environment the animal will restrict its blood circulation just under the skin in order to prevent excessive heat losses. In a hot environment the opposite happens; the blood circulation just under the skin is increased.

Sweating and increased respiration rate also help the animal to keep its body temperature within normal limits under hot conditions.

Sick animals which have an excessively high body temperature, are said to have a fever. Healthy animals can also have an increased body temperature, for example, after hard labour, under heavy stress or under exposure to the sun during a hot day.

The body temperature is measured in the rectum. A thermometer is put into the rectum for a few minutes for this purpose.

Milk production

When a cow is sick, milk production drops. It depends on the kind of disease whether the drop in production is large or small.

2 Causes of diseases affecting cows disease immunity

Every animal is exposed to the environment in which it lives. The environment can be favourable or unfavourable.

The body of an animal has means to resist disease-causing organisms. The level of resistance the body can give depends on genetic factors and the environment. If the environment is unfavourable, the animal's level of resistance against disease factors will decrease and consequently the animal's chance of becoming ill will increase.

Some unfavourable conditions which affect a cow are:

1 A lack of essential substances like oxygen, feed and water

A lack of oxygen can occur in indoor areas which lack proper ventilation. Animals tied to a rope can also suffer from a lack of oxygen and can even strangle themselves.

A lack of feed makes the cow use up its body reserves. The cow loses weight and becomes thin. In extreme cases, when the cow has lost up to about 40% of its normal body weight, it will die.

In countries with a very long dry season cows may die because of a lack of feed or water or both.

A lack of water results in serious illness. The body tissues dry out and eventually the cow will die.

Animals suffering from severe scours lose a lot of water and dehydrate. In severe cases of scours in calves, dehydration will often lead to death.

2 Tiredness

Tiredness (fatigue) occurs when the animal body has to labour much harder than is usual.

3 An unfavourable climate

Various factors related to 'climate' can have a negative effect on cows, particularly temperature and humidity.

High environmental temperatures may lead to a rise in body temperature. Cows can catch a cold because of draft (a sudden cooling of a part of the body). This can result in scours and pneumonia, particularly in calves.

4 Injuries

Injuries are wounds, bruises, broken legs, a.s.o.

5 Poisonous substances

The consumption of poisonous substances can disturb the processes in the animal body seriously and may even result in death.

A poison can be harmful to health, even in very small quantities.

6 Parasites and harmful micro-organisms

If an animal is in particularly poor condition, **parasites and harmful micro-organisms** may invade its body.

Diseases caused by micro-organisms are often **contagious**.

There are several types of parasites and micro-organisms harmful to cows.

2.1 Parasites

Diseases caused by parasites occur frequently and are therefore of great importance.

Parasites are living organisms which live on- or inside an animal and feed themselves at the expense of that animal. The animal is said to be their *host*.

Parasites damage their host because:

- in an indirect way they use feed from the host so that the host cannot benefit from this feed
- they cause damage to the host's body tissue
- they may form harmful substances (toxins) which are absorbed by the host and are poisonous

Parasites can be classified into **animal** parasites and **plant** parasites.

1 **Animal parasites** are:

- **Endoparasites** (living **in** the body, usually temporarily)

Intestinal parasites, lung worms and liver fluke belong to this category.

Cattle ingest them during grazing. Generally they multiply by laying large numbers of eggs which are then expelled. When the environment is humid and warm the eggs emerge from the larvae.

Protozoa are single-celled organisms with no rigid cell wall (unlike bacteria) and which can move by themselves. There are many types, e.g. coccidia causing coccidiosis in poultry.

- **Ectoparasites** (living **on** the body, whether temporarily or permanently)

The most important parasites belonging to this group are ticks and mites. They affect cattle and other domestic animals.

Also lice and fleas are ectoparasites.

- **Insects**

The tse-tse fly in Africa is a well-known example of a free-moving insect spreading harmful micro-organisms in cattle by biting.

2 **Plant parasites** are:

- **Fungi**

Fungi are found on or inside the skin of cattle. They can cause skin diseases and toxicoses.

2.2 Bacteria

Bacteria are unicellular organisms which multiply by means of division (one bacterium splits up into two). They are very small and can only be seen by using a microscope.

Bacteria can multiply very rapidly. Out of one bacterium more than 16 million can develop in 24 hours.

Bacteria are present everywhere, in feed, in water, on clothes, on equipment, etc. No object is free from them. Millions may be found just in a little scratch in a milk bucket!

By no means are all bacteria harmful to cattle. In fact only a few species are. Many bacteria are very useful, for instance, the bacteria present in the rumen of cattle.

Bacteria die when exposed to sunlight and drought but flourish in damp and dark places.

Under unfavourable conditions certain bacteria can survive for several years. To be able to do this they change into **spores**. Spores cannot multiply. When conditions become favourable they change back into bacteria again.

When bacteria enter the body, the animal will not fall ill right away. The bacteria first needs time to multiply. It is only when the bacteria and the toxins they produce are present in sufficient quantities that the animal becomes ill.

The lapse of time between contamination (infection) and the presence of disease symptoms is called the **incubation period**. This period is different for different diseases. It can vary from some days up to some months and is sometimes even longer.

Bacteria can be classified in different ways. One way is according to their **shape**; for instance, spherical, rod-shaped or spiral-shaped.

Another classification of bacteria is according to the amount of **oxygen** they need for optimal growth and multiplication.

Aerobic bacteria grow best in an environment containing enough fresh air.
Anaerobic bacteria grow best in the absence of oxygen. There are also species that hold an intermediate position.
Finally, bacteria may be classified by the way they **feed** themselves.
Pathogenic bacteria live on or in the living animal body. They 'feed' themselves at the expense of the host and cause infections and diseases.
Saprophytic bacteria feed themselves with dead substances.

A special group of micro-organisms are the **viruses and rickettsias**. They cause **highly contagious diseases**. These diseases often cannot be cured and have to be prevented (vaccination).
A virus is not the same as a bacterium. A virus is a thousand times smaller.

N.B.:

Usually a disease is not caused by just a *single* infectious organism. Several different organisms may be involved (the cause is 'multifactorial').

Mortality = death-rate, number of deaths in given period.
Morbidity = condition of being diseased; the morbidity rate is the proportion of sick to healthy animals
Sub-clinical disease = the cow is sick, but the symptoms are not manifest

The mortality rate alone is not an accurate indication of economic loss. Sub-clinical disease may be of much more economic importance than the combination of deaths and cows showing obvious disease.

Almost all cows (animals in general) in the tropics carry harmful micro-organisms/parasites of one sort or another. The numbers are often not sufficient to have a visible effect (the disease remains sub-clinical). But the cows do not grow and produce properly (milk, meat, animal draught power) as they should under the prevailing environmental conditions.
For instance, intestinal parasites alone can halve the production of a cow without the cow showing any sign of actual sickness.

2.3 Immunity and vaccination

Taking proper care of farm animals *is the most important thing to do in order to prevent diseases*. It will strengthen the resistance of the animals against diseases in general.

'Resistance' is a very complex matter. Important signs of good resistance are proper condition (the animal looks good and is lively), healthy mucous membranes and proper functioning of the stomach. 'Resistance' protects the animal from **all** diseases and temporarily unfavourable environmental conditions.

Generally speaking, **immunity** protects the animal from **one** specific disease. For that reason a high level of resistance is more important than immunity.

However, resistance and immunity cannot be separated from each other. A normal or even high level of resistance is needed to build up immunity. In general, proper animal care enhances both resistance and immunity.

Immunity

When disease-causing micro-organisms enter the body of a cow (animals, in general), through the skin, nose or mouth, the first reaction of the cow is to try to keep the infection localized. The body activates the mucous membranes and the lymph glands close to the place of infection. The lymph glands increase their production of **white blood cells**, which try to eliminate the disease-causing organisms. But if the latter multiply faster than the white blood cells, they and the toxins they produce spread through the body and the cow becomes ill.

Apart from activating the general defence mechanism (white blood cells), the body starts producing specific defence substances as well.

There are two types:

- **antibodies**, which eliminate the disease-causing organisms
- **antitoxins**, which eliminate the toxins.

These substances are called 'specific' because each type of disease-causing organism and the toxin it produces provokes the body to produce antibodies and antitoxins which are specially suited to eliminate that specific type of disease-causing organism and toxin.

If the animal body is able to produce antibodies and antitoxins at a faster rate than the 'enemy' multiplies and produces toxins, both the enemy and the toxins will be eliminated; the animal will recover from the disease.

If this is not the case, and if nothing is done the animal may die.

Fortunately, in many cases vets are able to cure animals by administering medication helping the body to fight the infection. In this way recovery will be faster; or animals which under natural circumstances would have died, can be saved.

Sometimes the disease-causing organisms are not completely eliminated and remain present in the animal body. In this case a cow is not in optimal condition and does not produce to her capacity. The disease is said to be in a **chronic** stage (with often no visible symptoms).

Under poor environmental conditions (for the cow), the disease may recur or, in other words, the disease may again reach the **acute** stage. Think of udder infection (mastitis).

Disease-causing organisms normally do not trouble every type of farm animal. For instance, a certain micro-organism affects poultry but does not affect cattle. Think of coccidiosis. This means that by nature cattle have something that makes them resistant to this micro-organism. In other words, cattle have a **natural immunity** against this micro-organism.

After an animal recovers from a disease, the antibodies will still be present in the body for some time. As long as they are present in sufficient quantities, this disease will not affect the animal again. The animal has built up **immunity** against this disease. It depends on the type of disease how long this immunity lasts. It can vary from a few months up to a lifetime.

Nowadays it is possible to give an animal immunity against a number of diseases **artificially**. This is done by **vaccinating** the animal, or, in other words, by giving the animal a **vaccine**. A vaccine is a culture of a weakened disease-causing organism. It has undergone some sort of treatment to make it less virulent, so that the vaccine will not make the animal very ill or ill at all. However, it is strong enough to make the body react to it by producing antibodies and thus building up an immunity against a certain disease.

In cattle, vaccines are normally administered by injection.

After the vaccine is injected, the animal body needs time to build up the immunity. This takes 1 to 2 weeks with cattle. The immunity lasts from some months up to several years, depending on the disease against which the vaccine was injected and the type of vaccine used. For instance, vaccination against Blackleg has to be repeated every year.

Although not all infectious diseases of cattle can be controlled by vaccination, vaccines are available for a number of dangerous cattle diseases worldwide.

Another way of giving an animal immunity against a disease is by injecting an **antiserum**, containing antibodies against that disease. This antiserum can come, for instance, from an animal that has

survived the disease. It is injected directly into the bloodstream and gives the animal immunity right away. The animal does not have to form the antibodies itself.

This form of immunity is called **passive immunity** whilst the immunity the animal builds up itself after vaccination is called **active immunity**.

The immunity obtained after an antiserum injection generally does not last long, from one week up to one month). This method is only used in emergencies, when there is an outbreak of a disease or in case an animal has to be protected for only a short time; for example, after an operation when there is a risk that the animal may be infected with tetanus through a wound.

3 Endo + ectoparasites of cattle

3.1 Endoparasites

Endoparasites live **in** the bodies of animals, in one or more of their organs, at the expense of their **host**. But part of their life-cycle is usually external.

Intestinal parasites

Roundworms (nematodes), or simply ‘worms’, are intestinal parasites of cattle. There are many different intestinal parasites and they cause large economic losses to (dairy) cattle farmers all over the world.

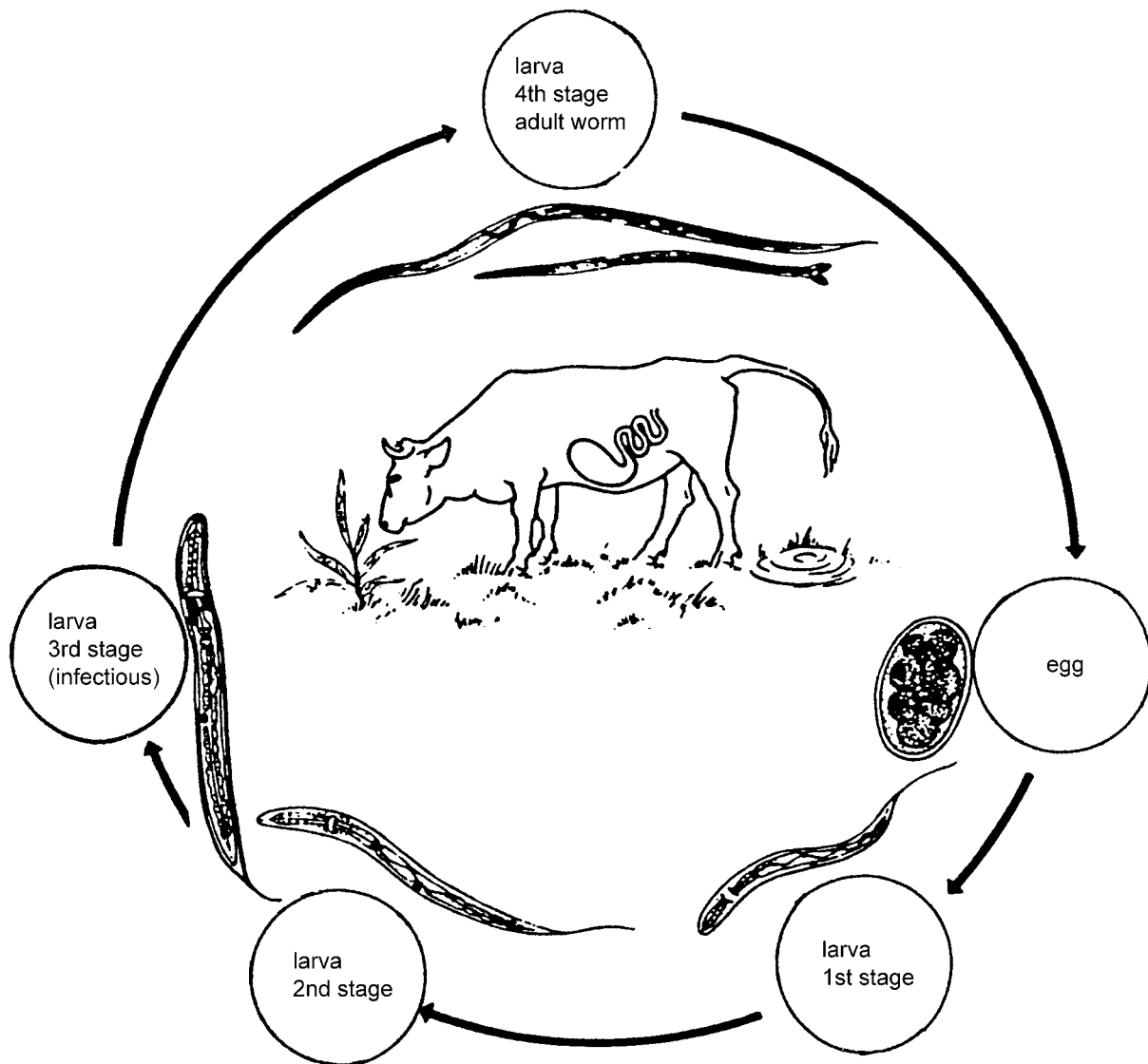

Figure 1: The life-cycle of intestinal parasites (stomach-intestines)

Life-cycle

The life-cycle of intestinal parasites is illustrated on the following page. Adult female worms lay large numbers of eggs in the intestinal tract of the host; the eggs are expelled with the faeces. The faeces form a good environment for the eggs and for the larvae which emerge from the eggs. Eggs as well as larvae cannot stand dry conditions.

These larvae develop into a second and third stage. The third stage larvae spread out over the pasture; rain helps them leave the faeces.

These third stage larvae are the infectious ones. They cannot feed themselves which means that they need a host animal. If they are not ingested by the cattle, they die after some time. Those which are ingested can grow and develop into adult worms in the cows.

Under favourable conditions for the worms, the whole life-cycle of the worms takes about five weeks.

The number of adult worms present in the stomach and the intestinal tract influences the development of the infectious larvae into adult worms. If the number of adult worms is already rather high, fewer larvae will get the chance to develop into adult worms than if the number of adult worms is low. This mechanism is very important in keeping the number of worms inside the host within certain limits and in preventing serious sickness of the host animal. However, it can be imbalanced under unfavourable conditions for the cow.

Young cattle (calves!) are very vulnerable to worm infections. They still have to develop the mechanism to keep the number of worms under control. In other words, they still have to build up a degree of resistance against worms.

Symptoms

The symptoms which indicate whether a (young) cow is infected heavily with intestinal parasites are not very specific. They often occur when the animal has other problems as well.

The symptoms are:

- decreased growth rate
- a dry, not shiny and open coat of hair
- anaemia (lack of blood) and decreased body weight
- decreased appetite
- at times, a change in the consistency of the faeces (scours)

Diagnosis

The only reliable method of determining if an animal is infested with intestinal parasites is to examine the faeces under a microscope, for the presence of eggs.

Apart from this, examination of the blood and the grass may be helpful.

Treatment and prevention

- Feed the young animals well.
- They can be treated with a 'dewormer' (a medicine) during the wet season, to prevent heavy infections (so-called drenching).
- Calves should not be put into pastures which are heavily infested with parasites.
Pastures which are always used to graze calves are normally heavily infested with parasites. A way to 'clean' those pastures is to mow them and remove the old grass every time the calves have grazed the pasture.
- Calves should never stay in the same pasture for more than two weeks. After a fortnight the number of infectious larvae increases. This is due to the fact that the eggs which the calves expelled when coming into the pasture are developing into infectious larvae around this time.
- Keep the calves indoors and feed them grass from a pasture that is never grazed by cattle. The older the calves are when they are put to pasture, the better it is.
- Let the calves graze ahead of adult cows. In this way they get good grass and because they only eat the top parts, they will not get heavily infected with intestinal parasites.
However, this system is often difficult to realize in practice, because of the extra fencing required.

To prevent heavy parasite infection in calves, a **combination** of some of the above-mentioned measures will have to be taken.

Lungworm

Adult lungworms are 5-8 cm long and live in the bronchi of young cows. Female worms lay up to 200 eggs/day; they are coughed up and then swallowed by the animal. During their journey through the intestinal tract, the eggs mature and larvae emerge.

This is why only larvae and not eggs, are found in the faeces. Outside the host, the larvae in the faeces develop into infectious larvae within 6-7 days. Together with grass, infectious larvae are ingested by the animals. After changing somewhat in the abomasum, they enter the intestinal tract and break through the intestinal wall into the bloodstream and the lymphatic system. They are then transported to the lungs where they break out of the blood vessels and enter the lung tissues. Here they grow and become adult worms. The whole process takes about 3-4 weeks.

The total life-cycle of the worms, including the part outside the host, takes 4-5 weeks under favourable conditions for the worm. Infectious larvae are very sensitive to sunlight and dry conditions.

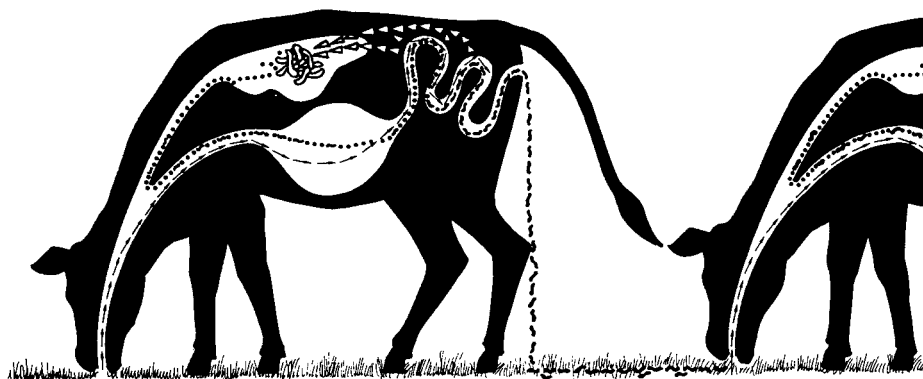

Figure 2: The life-cycle of the lungworm

Symptoms

Young cattle (calves and heifers) in particular may show disease symptoms such as coughing, depression, poor appetite and loss of body weight. Older animals which were infected in early life have built up some resistance and will only get into problems after heavy infection.

Diagnosis

Infections can be diagnosed by examination of the faeces and saliva. Look for larvae and, in the saliva, look for eggs as well.

Treatment and prevention

- There are 'dewormers' (medicines) available which act against lungworms. After treatment the animals should be moved to a clean (a recently mown) pasture to prevent new infection.
- The same grazing management practices helpful in the prevention of heavy intestinal parasite infection are also effective in preventing heavy lungworm infection.
- Specially treated larvae can be administered to young calves at an age of 6 weeks and again at 10 weeks, to help the calves build up an immunity.

To prevent all infection the calves have to be kept indoors. The treated larvae will not make the calves sick but will stimulate the build-up of some resistance. About two weeks after the last treatment the calves can go out on the pasture. The resistance will be preserved when the calves are infected with normal larvae when they are grazing.

Liver fluke (Fasciola)

The liver fluke *Fasciola hepatica* (a trematode) is widely spread in temperate and subtropical regions and also in higher altitude tropical areas. It mainly affects sheep but also cattle and other ruminants. The mature liver fluke lives in the bile ducts of the liver and the immature forms in the liver tissue itself.

The adults are about 18-30 mm long and 4-13 mm thick. Their colour is a dirty grey to brownish.

Liver fluke disease occurs mainly in animals grazing on wet pasture.

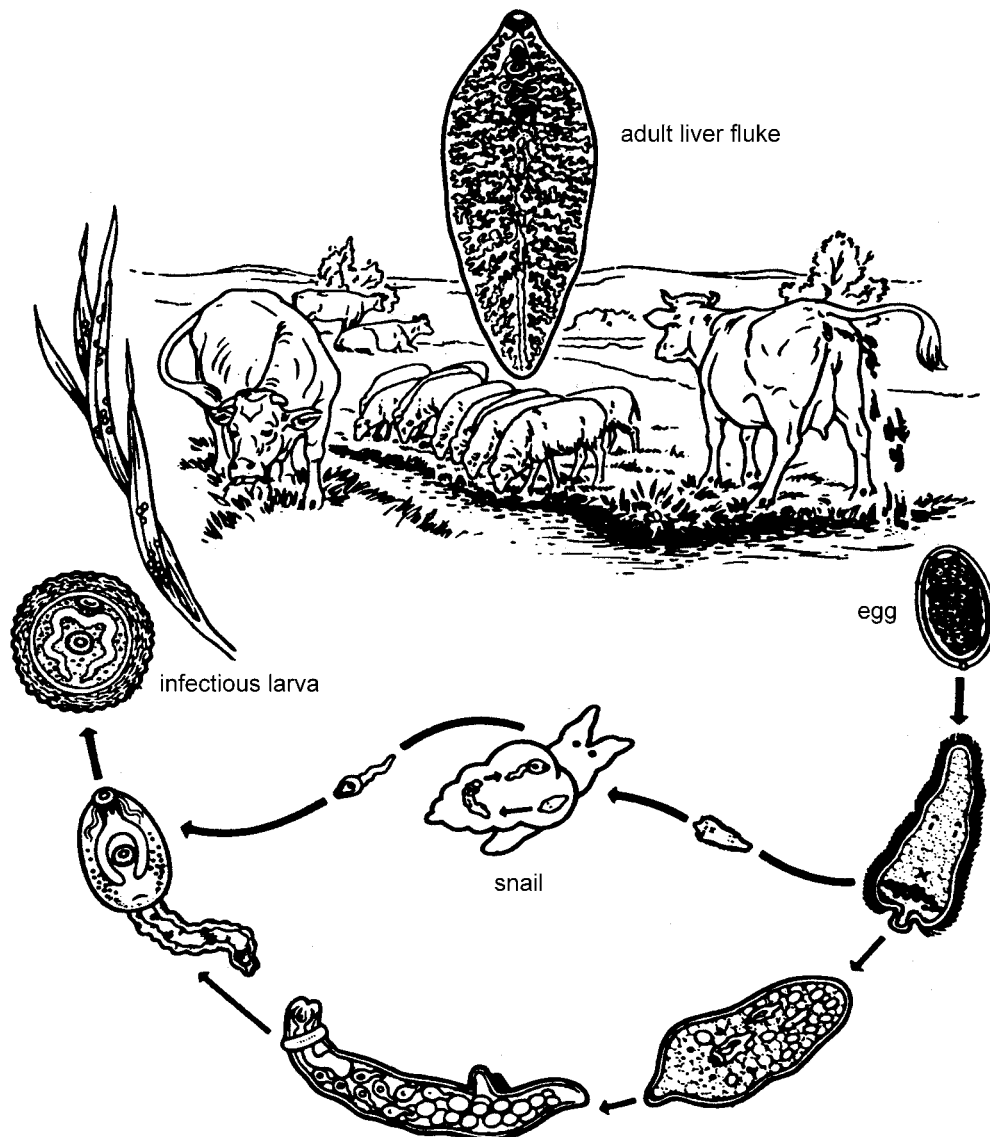

Figure 3: The life-cycle of the liver fluke

Life-cycle

The eggs of the fluke pass down the bile ducts into the intestine of the host and are expelled with the faeces.

For their further development they require as their 'intermediate host' a **snail** which lives mainly in mud (so-called land snails). The parasites pass through several development stages in the snail before they emerge, and then attach themselves in the form of cysts to grass blades. This cyst is the infectious form.

When the cysts are picked up by a grazing animal, the wall of the cyst dissolves in the intestinal tract and the young fluke emerges.

After boring through the wall of the intestine and then the capsule of the liver, it spends 6-8 weeks wandering about in the liver before settling down in a bile duct.

The total period of development in the host, i.e. from the swallowing of the cyst by the host to sexual maturity of the parasite, amounts to 2½ to 3 months. The adult fluke lives for about one year.

Symptoms and diagnosis

Affected cows and sheep will show decreased milk production, lose body weight and develop anaemia.

The symptoms are not very specific.

Infections can be diagnosed by examining the faeces under a microscope. Look for eggs.

In slaughtered animals the liver can be examined for the presence of liver flukes.

Treatment and prevention

Specific liver fluke-killing medicines are available. It is important to use the right doses.

Infection can be reduced by controlling the amount of snails in the environment. This can be done by making the environment less favourable for snails, for instance by improving the drainage of the pasture.

In the tropics *Fasciola gigantica* is economically the most damaging fluke. It mainly affects cattle but also sheep and other ruminants. It generally uses a water snail as its intermediate host.

Medicines against intestinal worms and liver flukes are called **anthelmintics**. It should be noted that anthelmintic resistance to drugs has developed in many places, particularly in South America.

3.2 Ectoparasites

Ticks

Ticks are everywhere and they transmit several serious viral and protozoan livestock diseases. **Tick control is one of the first requirements for successful dairy farming in most warm countries.**

Many different species of ticks are known; not all of them are of economic importance.

Ticks feed on the blood of their host. In the 'unfed' stage ticks are usually flat but when engorged with blood they are more or less spherical.

Ticks are capable of taking in many times their own weight in blood, with a corresponding increase in size.

Apart from the loss of blood, which in heavy infestations may be considerable, ticks injure their host chiefly by the toxic effect of their saliva **and by the transmission of diseases.**

The damage done to the skin by the attachment of the tick may also cause the skin to become inflamed and permit the entry of other parasites such as screw worms.

The damaged skin itself is of reduced value to the leather industry, even when the wounds have healed before slaughter.

Life-cycle

During its development the tick passes through the stages of egg, larva and nymph before it becomes adult.

The eggs are laid on the ground. The larvae which emerge from these eggs climb high up on grass blades and attach themselves to a passing host.

According to their method of further development, ticks are divided into one-host, two or three-host ticks.

The first group goes through all the stages of development on one and the same animal. In the case of two-host ticks the larvae develop into nymphs on the first host. The nymphs then drop down on the ground and moult into adults, which become attached to the second host. Three-host ticks attach themselves to a different animal at each stage of development, dropping down and moulting into the next stage on the ground.

The time taken for completion of the life-cycle differs from one species of tick to another and is largely dependent upon climatic factors. In the most important cattle ticks the development period of each stage (larva, nymph, adult) on the host is generally one week.

The survival time of the various stages on the ground, in the absence of a host, without feeding, may be considerable, sometimes several months. During this time there is no further development of the tick but the pasture remains infested!

Control

Ticks can only be 'attacked' when they are on their host animal. For this purpose certain insecticides are used, called **acaricides**. After an application of acaricides on the host (which has killed the ticks), re-infestation is prevented or limited for some time.

Acaricides are applied in the form of **sprays or dips**. Regular and proper application of acaricides against ticks will also be effective against most other ectoparasites.

Ticks can become **resistant** to acaricides. However, it may take many years for resistance to develop. When resistance is observed, the amount of acaricide can be increased but this will not help for long. The best thing to do is to switch to another acaricide with a different chemical composition.

If the treatment does not seem to be very effective, it does not mean resistance is developing but more likely the treatment is not being carried out according to instructions.

To keep the ticks under control, **regular treatment** is necessary. The frequency depends on the season, the breed of cattle and the effectiveness of the chemical used. However, in areas where ticks are common it will normally vary from once a week to once every three weeks.

In areas where ticks are a menace, tick control should be **thoroughly discussed and practised during training programmes**.

Generally speaking, tick control by acaricides and curative drugs is becoming more and more difficult because of the increasing resistance of ticks to various chemicals and because of residues of these chemicals in meat and milk.

In recent years the accent of tick control has shifted to more flexibility, integrating various control measures. Economic factors and public health concerns have played a role in this.

Insects

In Africa the **tse-tse fly** is important because of its role in the transmission of cattle sleeping sickness (nagana; trypanosomiasis).

Actual cattle sleeping sickness is a disease caused by blood parasites. This disease is difficult and expensive to control with medicines.

There are various strategies to control the tse-tse fly itself, which is the transmitter of the disease.

Several other insects play a role in the transmission of cattle diseases.

Mites can cause extensive damage to skins.

Acaricides used to control ticks are often effective against other ectoparasites as well.

So called 'zero-grazing' minimizes the risk of infection with tick-borne diseases and trypanosomiasis.

4 Some important diseases which may affect dairy cattle

A disease that may be of importance in one country or region may be absent or of little significance in another.

The following is **very general introductory information** on some (dairy) cattle diseases which are important worldwide.

Diseases associated with **reproduction** are treated in our guide REPRODUCTION IN DAIRY CATTLE (2 parts).

The introduction of exotic blood in local dairy cattle goes along with **foot and leg problems** (e.g. over-grown claws) They are dealt with in our guide FOOT CARE IN CATTLE.

Farmers often cite **mastitis** as one of their major problems. It is also a problem for the small farmer. Cleanliness of cow and utensils, milking area, the milker, timely milk transport, are very important. Mastitis is particularly common in zero grazing. There is a chapter on **mastitis** in volume 2 of our MODERN DAIRY FARMING series.

CMlf diseases receive attention in the following chapter of this guide.

Further reading: H.T.B.Hall 'Diseases and Parasites of Livestock in the Tropics'.

Intermediate Tropical Agriculture Series, Longman, London and New York.

The above book is about livestock diseases and parasites in the tropics in general (not just cattle). Its level is 'academic'.

Our suggestion: seek additional information & advice locally, for diseases and problems which occur on your particular farm or on farms in the neighbourhood, or in your area or region. Our present text is merely an introduction, pointing out certain diseases which often occur in (dairy) cattle farming worldwide. Use the 'empty' pages in this guide for information which is of local importance.

4.1 Diseases due to deficiencies, toxic substances and metabolic disorders

Milk fever (hypocalcaemia)

Milk fever is a metabolic disease which can occur just before, during, but usually shortly after calving (1 to 2 days).

Milk fever occurs almost exclusively in older cows which are (very) high producers.

Genetic factors may be involved which make one cow more susceptible than another.

Causes

In a case of milk fever the calcium content of the blood of the cow is reduced, often to half the normal level. Calcium content depends on the amounts of calcium entering and leaving the blood. The blood receives calcium from the digestive process and from the calcium-release of the bones of the cow. Loss of calcium (secretion) takes place via the urine and (colostrum) milk.

The calcium metabolism is regulated by certain hormones and by vitamin D. During and after calving a lot of calcium is secreted by the blood into the udder.

The calcium requirement for milk production increases rapidly at this time. If this requirement is not met by new calcium entering the blood, the calcium content of the blood will drop and if the drop is large, 'milk fever' will be the result.

It should be noted, however, that milk fever is not a disease caused by a lack of calcium. Normally there is enough calcium in the feed. The problem is that the calcium metabolism has to adjust itself to a rapidly increasing requirement.

Symptoms

The symptoms which can be observed are a consequence of the decreased calcium content of the blood. This causes functional disturbances in the muscle system of the cow.

The symptoms are:

- the cow seems 'dull and silent'
- the body temperature drops a little
- extremities (ears, feet) may feel 'cold'
- refusal of feed, especially concentrate
- no rumen contractions
- no faeces or only little dry, stiff faeces
- the udder becomes flabby, no milk is let down
- the cow has difficulty in standing up and after a while cannot get up at all. Following this the cow becomes more or less unconscious
- if the disease occurs before or during calving, the labour pains may weaken and the delivery may need assistance.

Treatment

- An injection of a calcium solution by a veterinarian. Some magnesium is added to this solution to decrease the effect of calcium on the heart of the cow.
After 10 to 15 minutes the cow is able to stand up again and starts to eat a little. Defecation occurs again.
Recovery is often spectacular (which is nice for the vet).
- It is not good practice to milk the cow completely for the first few days after treatment.
- Sometimes the cow may show symptoms again 12-24 hours after the first treatment. Quick treatment is then necessary.

Prevention

- Do not give too much concentrate to cows in the last week before calving. 'Steaming-up' increases the risk of milk fever.
- Give the cow her normal diet after calving to make sure she consumes enough calcium.
- Do not milk the cow completely for the first few days after calving. This limits the milk formation in the udder somewhat and therefore the outflow of calcium from the blood.
- The cow should have ample space during and after calving and should have room to walk about.

It is very important to try to prevent cows which have had milk fever once, from getting it again the next time they calve.

Tympany (bloat)

Tympany is a problem with the gas produced in the rumen: the gas cannot escape from the rumen for one reason or another.

The susceptibility to this disorder varies from one cow to another; therefore it is likely that genetic factors are involved.

Causes

Normally the gases which are produced in the rumen are belched up by the cow. With tympany the gas cannot get out of the rumen. Possible causes are:

- A disruption in the motility (contractions) of rumen and reticulum. When a cow does not get enough fibrous material (roughage) in her diet or when she gets large quantities of concentrate, layering in the rumen may not come about. This means that the gas layer is mixed up with the other layers and foam formation is the result. This foam cannot be belched up and bloat may occur.
- The use of certain feedstuffs increases the risk of bloat when they are fed in large amounts. For instance, lucerne, clover, very young grass, potatoes and cabbage leaves.
- The gullet is blocked, for instance by a potato.

- The rumen wall is inflamed.
- The presence of warts where the gullet enters the rumen, causing partial blockage of the gullet.

Symptoms

- standing behind the cow, one can see that the left flank is swollen
- the cow is depressed and restless
- sometimes the animal has its mouth open
- the cow stands up and lies down frequently
- the cow kicks with her hind legs at her belly
- groaning
- the cow defecates and urinates often
- sometimes death occurs through suffocation

Treatment

- Put the animal in a position so that the hind legs are lower than the front legs.
- Give the animal exercise.
- An attempt may be made to get the surplus gas out of the rumen by putting a piece of hose through the gullet into the rumen. This is of use when the bloat is caused by a blockage of the gullet. Hold the head of the cow high and put the hose far back into the throat to prevent it from entering the wind pipe. The hose should not have a sharp rim.
If no air comes out of the hose, the bloat is the result of foam formation in the rumen.
- To get rid of the foam in the rumen, lukewarm oil can be given to the cow, for instance, cooking oil; for an adult cow ½ to 1 litre is needed.
- If none of the aforementioned treatments is successful, a veterinarian has to be called. He may apply medication to reduce the formation of foam in the rumen.
- **In very serious (acute)** cases the cow's life is in danger and quick action is needed. The rumen may have to be punctured. This is done by stabbing the animal in the left flank where the rumen lies under the skin.
- If the cow recovers, give her some roughage like long grass. Do not give concentrate for the first few days.

Prevention

Ensure the cows receive enough roughage in their daily ration to ensure proper functioning of the rumen.

4.2 Viral Infections

Rinderpest (cattle plague)

Rinderpest is a viral disease. The virus is transmitted by direct or indirect contact between infected and susceptible cattle.

Rinderpest used to be the **most serious cattle disease** (quite recently in Africa, and in Europe in earlier centuries).

Recently it has again become something that should be actively watched, not only in Africa but also in parts of Asia.

In its classical form, rinderpest shows typical necrotic mouth lesions, stinking breath and haemorrhagic diarrhoea.

In principle rinderpest can easily be prevented by **vaccination**. However, there may be logistic problems, for instance, with the cooling of the vaccine. Civil disorders may disrupt vaccination programmes. Moreover, each campaign should be followed by **annual** vaccination of young stock.

Vaccination against rinderpest may be combined with other vaccinations.

Foot-and-mouth disease (FMD)

FMD is a **highly contagious disease** affecting cattle in particular. However, sheep, goats and other cloven-footed animals can be affected as well.

The disease is known in many countries all over the world.

Cause

The cause of this disease is a **virus**.

The disease is spread chiefly by the contents of the characteristic blisters on bursting and by the milk, urine, nasal discharge and other secretions which convey the infection directly from a sick cow to a healthy one. Indirect infection also occurs, by contact with clothing, tools, feed troughs, wool, milk and meat.

The virus can also be spread by other animals which are not themselves susceptible to the disease (dogs, cats).

A cow which has recovered from the disease may become a carrier.

The incubation period is 3-8 days.

Symptoms

The first sign of the disease is a rise in temperature, which, being of short duration, often passes unnoticed.

After this, the disease shows itself in loss of appetite, slow rumination and the escape of saliva from the mouth in long, ropy strands. Often the infected cow can be seen standing motionless with glazed, staring eyes.

Within 2-3 days, blisters filled with a clear yellow fluid appear. They spread rapidly over the whole mucous membrane of the mouth and then burst allowing their contents to escape and leaving behind raw areas which are very painful and occasionally bleed.

At the same time small blisters appear on the feet. The cow is unwilling to stand up and can only move with much pain. Usually there are also blisters on the udder teats and the whole udder is swollen and tense.

Milk production drops and the milk looks yellowish and develops a somewhat bitter taste. Subsequently there are often fertility problems.

Another disease, **vesicular stomatitis** (inflammation of the mouth with blisters) looks like foot-and-mouth disease but is not FMD.

Control

Major dairy cattle exporting countries are free from FMD and may even have stopped preventive yearly vaccination (member countries of the European Union EU, since 1992; USA, Japan). But occasional, localized outbreaks are still possible; they will immediately be suppressed should they occur, under the officially adopted 'stamping out' policy.

Stamping-out was actually practised in 2000-2001, in the UK (many outbreaks), France (just one or two) and Holland (several outbreaks, limited to certain districts). Stamping-out proved to be effective, at least in Holland and France and they have been officially declared FMD-free again (we write October 2001). But stamping-out in practice caused considerable public concern, particularly in Holland (TV screens; images of protesting farmers and ugly scenes). The public was shocked by the ruthlessness of the policy; not only affected cows, but all (healthy) cows on a farm, together with all other cloven-footed animals on a farm were destroyed. And also on farms surrounding the farm on which FMD was discovered.

The present EU non-vaccination policy may be revised. However, nowadays there are many FMD virus strains, requiring different vaccines. Hundred percent protection by yearly preventive vaccination is impossible. And, of course, the cost of preventive vaccination is considerable.

In other regions or countries outside the EU, USA and Japan, FMD may still occur frequently. If it is the national policy to eradicate the disease, infected animals should be killed and their carcasses

burned and buried. Animals should not be moved from one area to another (no marketing). Restrictions on visits to an infected farm and frequent disinfection of floors and equipment help to prevent the further spread of the disease and helps to protect neighbouring herds from attack. In this way the economic loss caused by this disease can be considerably reduced.

It should be remembered that FMD is highly contagious and only a nation-wide campaign with strict regulations adhered to by every dairy farmer will ensure success in the long run.

Yearly preventive vaccination is likely to be necessary for several years.

However, vaccines may not be of the right type and quality everywhere, it may not be easy to isolate infected cattle and it may not be possible to financially compensate farmers for the loss of cows which have to be slaughtered. Eradication of FMD and other infectious cattle diseases requires a highly developed, and hence costly 'infrastructure' without which it will not succeed.

In areas where the disease is prevalent and where there is no national eradication campaign, vaccination may be carried out to reduce the prevalence of the disease. Vaccination should probably be repeated every eight months, because in many countries the duration of immunity after vaccination cannot be relied upon beyond eight months .

In southern Africa, the African buffalo maintains the FMD virus. FMD is therefore not eradicable in that region.

Rift Valley Fever (RVF)

Rift Valley Fever is caused by a mosquito-borne virus. The symptoms are fever with a bleeding tendency. A wide variety of domestic and wild ruminants are susceptible to RVF, with newborn animals being most susceptible. RVF has the potential to also occur outside Africa

4.3 Bacterial Infections

Tuberculosis (TB)

Tuberculosis is a disease from which few countries are free. All domestic animals, including man, are susceptible. In certain countries the presence of TB in wildlife may be a major issue.

Cause

The organism causing tuberculosis is **Mycobacterium tuberculosis**, which occurs as a human, bovine and avian type. The animal body may retain the bacteria for many years in encapsulated lesions in the lungs or in other organs.

Under certain conditions the capsule may break open and the bacteria may spread through the body.

In this stage the disease is contagious and can pass on to other animals.

The drinking of milk from infected udders by calves is the most common method of transmission in cattle.

Human beings can also be infected in this way (the drinking of infected milk). Infection can also be spread through the air or by direct contact (wound infection).

The disease is usually chronic.

Symptoms

As almost any organ in the cow's body may become involved, there are no clear-cut symptoms indicating the presence of the disease; it depends on which organs are infected.

However, tuberculosis should be suspected when there is a loss of condition without apparent cause, accompanied by swelling of the lymph glands at the angle of the jaw, in front of the shoulder or behind and to one side of the udder.

If the udder is infected, the milk yield drops and hard nodules can be felt in the udder, which becomes enlarged.

If the lungs are infected, there is a dry cough which becomes more frequent and painful as the disease progresses.

There may be yellowish-grey or blood-stained sputum.

Control

The only way to identify the disease in live animals is the use of the **tuberculin test**.

A small quantity of tuberculin is injected under the skin in the neck or tail area.

If tuberculin bacteria are present in the body, a reaction occurs. The spot becomes inflamed and enlarges (formation of a lump) within 72 hours.

If eradication is necessary infected animals should be destroyed. Cow houses occupied by infected animals should be thoroughly disinfected.

Vaccination is possible but is not often used. Vaccinated animals react to the tuberculin test.

Mycobacterium para-tuberculosis is associated with Crohn diseases of humans (a chronic intestinal disease). Never drink raw milk.

Anthrax

Anthrax is a highly contagious disease. All animals are susceptible, particularly ruminants and horses. The disease occurs worldwide, but is more common in tropical than in temperate countries. Its presence dates back to ancient times. It can affect humans as well (starting with spores infecting wounds on the skin or infecting the lungs or intestines).

Cause

Anthrax is a **bacterial disease**, in cows characterised by sudden death and black, tarry substance coming out of the natural openings of the body. The bacterium which causes it is called *Bacillus anthracis*. It is a spore-forming bacterium and the spores can survive in the soil for many years.

Animals are usually infected by coming into contact with infected material. The disease usually runs a very acute course. The incubation period is 1-3 days, sometimes a little longer.

Symptoms

An affected animal has a high fever, dark mucous membranes and shows distressed breathing, grinding of teeth, extreme weakness, bloating and in the final stages swelling (oedema) in the region of the neck, breast, flanks and genital organs.

Localized superficial swellings (carbuncles) may appear, especially in cattle. The swellings are first hot and painful but later cool and insensitive.

The disease may last for only a few hours to a few days before death occurs. Because the disease develops so quickly, animals may be often dead before any symptoms are noticed.

Control

By the time the cow is seen to be sick treatment is usually too late to be of value.

In areas in which anthrax is known to occur it is advisable to **vaccinate** all stock.

Dead animals should be treated with e.g. quicklime and then deeply buried. That is how anthrax was eradicated in the Netherlands early in the past century. Persons who have come into contact with an infected animal (alive or dead) or with infected equipment should thoroughly clean and disinfect the exposed parts of their body and also their clothing including footwear.

Note:

In many countries in the (sub)tropics there are vaccination programmes against major infectious diseases such as anthrax, blackleg, enterotoxaemia and other clostridial diseases not mentioned here.

Tetanus

Tetanus is an infectious disease affecting all animals as well as man; it is characterized by muscle spasms and stiffness.

Cause

Tetanus is caused by an **anaerobic bacterium called Clostridium tetani**. Infection takes place by contamination of wounds with the bacteria. The bacteria produce toxins in the wound, which go to the brain where they cause a marked exaggeration of the responses to normal stimuli. As a consequence intermittent muscular tension occurs.

Symptoms

The incubation period is 1 to 2 weeks, but can sometimes be considerably longer. The first signs of the disease are an increasing stiffness, resulting in the inability to masticate and to move the ears. Walking also becomes difficult.

The muscles under the skin feel tensed (hard). Because of spasms of the muscles involved in respiration, breathing becomes shallow and extremely rapid. In fatal cases the animal suffocates. A high fever develops before the animal dies.

After the onset of the symptoms, death occurs after 5 to 10 days in fatal cases; in young animals death may occur sooner.

Mild cases take up several months to recover.

Treatment

Treatment is difficult and is often unsuccessful.

However, an **antiserum** injection can be given, together with penicillin injections to help destroy the bacteria (see page 7).

Medicines to relax the muscle tension should be administered over a 1 to 2 weeks period.

Prevention

Proper hygiene and cleanliness after castration and other surgical operations should be observed. Wounds should be properly disinfected and should be kept free from contamination with dirt (the bacteria are in the dirt).

Wounds caused by rusty nails and wire need very careful attention.

Immediately after a surgical operation, antiserum should be injected to give the animal passive immunity. Horses especially are very susceptible to this disease.

Vaccination is another preventive measure to obtain active immunity.

Blackleg (blackquarter)

Blackleg is an infectious but non-contagious disease.

Young cattle are especially susceptible (age from six months to three years). Usually the disease becomes acute after an incubation period of 1-3 days.

The disease occurs in almost every country in the world.

Cause

Blackleg is caused by an **anaerobic bacterium called Clostridium chauvoei**.

When this bacterium is exposed to very unfavourable conditions, it assumes a very resistant form (spore) which can remain alive in the soil for a very long time. Blackleg occurs regularly in places with spores in the soil.

The spores enter the animal body through wounds or injuries; oral infection is also possible.

In the cow's body the spores change into bacteria again, and start to multiply.

Symptoms

The first signs of the disease are the sudden onset of bodily discomfort, fever and lameness.

After a short time generalized or localized swellings appear, usually in the areas covered with muscle such as the thigh, rump, shoulder, breast and neck.

At first these swellings are warm and painful but later generally cool and insensitive. The overlying skin is dry and tight, dark or even black. When handled it produces a peculiar crackling or rustling sound (crepitation) and it sounds hollow on being tapped.

The cow has respiratory problems and sometimes colic (severe griping pains in the belly).

Death occurs. Quite often cows die so rapidly that the disease symptoms remain unnoticed (cows are found dead).

Control

The treatment of affected cows is unlikely to be effective. Dead animals should be burned, not simply buried, as the spores would stay alive in the soil for many years.

In areas where the disease is known to occur, stock between six months and two years should be **vaccinated**.

Contagious bovine pleuropneumonia (CBPP)

Contagious bovine pleuropneumonia or 'lungsickness' is an acute, subacute or chronic disease of cattle caused by *Mycoplasma mycoides*.

CBPP was eradicated from much of Europe. At present the disease occurs in parts of Asia and in certain African countries.

CBPP is transmitted by direct contact (respiration). The affected cattle have a frequent, painful cough and are clearly not in good form.

The introduction of CBPP into an area or a herd previously free of the disease is usually effected by a carrier animal. It then spreads slowly through a herd eventually resulting in a high morbidity. In areas where the disease is endemic many of the animals are immune

Where the disease occurs, care must be taken to ensure that there are no infected cattle in any intensive livestock unit.

CBPP can easily go undetected for long periods of time and cause severe cattle losses. It is considered to be one of the most important cattle diseases in Africa.

Control is carried out by annual **vaccination** and **slaughter** of infected animals. This requires, as always, a well-organized veterinary service with sufficient funds, staff and equipment, excellent diagnostic services and the full co-operation of stock owners (compensation, education). No cattle may move in or out of a cordoned-off area. The above control measures have recently been quite successful in Botswana, for instance.

4.4 Tick-borne diseases

There are several tick-borne diseases:

Theileriosis

Commonly called East Coast Fever ECF or Mediterranean Fever.

Theileriosis is a major constraint to livestock production in the Mediterranean basin and large parts of Africa, the Middle East and the Far East.

Symptoms are high fever, listlessness and a frothy exudate at the nostrils just before death.

The disease is caused by parasitic protozoans (*Theileria*, various forms) transmitted by ticks.

Proper tick control is of the utmost importance where this and other tick-borne diseases occur.

It has been reported that the only practical method for **vaccination** against ECF is the 'infection and treatment' method, developed in Kenya. Cows are infected by injecting large amounts of sporozites (the infectious material) obtained from infected ticks, and are simultaneously injected with long acting tetracycline to limit parasite multiplication. There may be later developments.

Heartwater

Heartwater is a rickettsial disease (Cowdria) only known in sub-Saharan Africa and certain Caribbean islands.

The symptoms are fever, nervous signs, convulsions.

Heartwater also affects sheep and goats.

Cure with antibiotics is possible, but there is little time. Vaccination is a possibility and is being researched.

Babesiosis

Also called piroplasmosis, or Texas fever, tick fever and redwater. It is widespread throughout the tropical world.

It is a protozoal disease (*Babesia*) transmitted by blood-sucking ticks.

The symptoms are fever, coloured urine, progressive weakness and increased heart rate & respiration.

Anaplasmosis

Anaplasmosis is another tick-borne disease.

The disease affects cattle especially but can also occur in sheep and goats. The disease does not result in high mortality but can cause severe economic loss because of the serious debility (weakness) of infected animals.

Indian cattle (*Zebu*) are more resistant to the disease than cattle originating from temperate regions. It seems that older animals are more susceptible than younger animals.

Cause

Anaplasmosis is caused by parasites, called anaplasms, which live in red blood cells. The anaplasm is considered to belong to the rickettsiae. These are small micro-organisms which can multiply only in living cells.

The disease is transmitted by ticks and certain flies which are the natural hosts of the anaplasms.

Symptoms

In the early stages of the disease there is usually a brief rise in temperature, which may return to normal as the infection proceeds.

Breathing is rapid and difficult. The animal shows signs of exhaustion, with cessation of rumination and loss of appetite. After the disease has been present for some time, the skin and mucous membranes become yellow and pale (anaemic).

The cows may be seen eating soil. Their gait is stiff and unsteady and they urinate frequently.

Sometimes there is constipation and sometimes the faeces contain blood or are coated with slime.

The lymph glands are enlarged and there is swelling around the eyes.

In chronic cases the disease may last for more than 2-4 weeks after the appearance of the first symptoms. There is severe anaemia from which the cow makes a only partial recovery after several weeks.

In acute cases (not very common) the cow may die within 3-4 days.

Control

No effective method of treatment is known but antibiotics can help to relieve the situation. However, they will not eliminate all the anaplasms and the cow will remain a carrier and may get sick again.

To reduce the severity of the disease, sick animals should be separated from the herd and should be provided with shelter and a good supply of clean water.

Vaccination is possible but does not give complete protection.

A proper tick-control programme also helps to protect the cows against anaplasmosis.

4.5 Fungal Diseases

Ringworm

Ringworm is a disease of the skin and hair which occurs worldwide and affects many animals, not just cattle.

It occurs most frequently under conditions where the skin remains wet for a long time and where temperatures are high.

Cause

Ringworm is a **fungal disease**. The fungus may be transmitted from one cow to another by direct contact, by brushes, halters and ropes. The wind may spread the fungus and birds can also transmit it.

Symptoms

Crusts of about 3 cm wide are formed. Later the crusts become thicker and after that they fall off and the skin surface, at first wet, becomes dry again after which hair starts to grow again.

Itching may be seen but is not a feature of ringworm infection. It may occur as the result of a bacterial infection of the skin after the crusts have fallen off.

Crusts appear mostly on the nose, ears, above the eyes and on the perineum (region of the body between anus & scrotum or vulva).

The whole process may take up to four months, from first symptoms to recovery.

Animals which have recovered are immune to re-infection with the same fungus, sometimes for long periods.

Control

Infected animals should be isolated from the herd.

For individual treatment, gentle brushing and washing of the crust areas with a fungicide will be helpful.

The disease can spread to man, so care has to be taken when working with infected animals.

Additional notes:

(1)

Cattle diseases may also be classified in another way. As follows.

(a) group 1

Diseases like rinder pest, CBPP, FMD which are independent of ecozones or production systems and cause high mortalities and severe economic loss. The technical solutions are largely known, and control depends mainly on socio-economic circumstances.

(b) group 2

Diseases which are mainly vector-transmitted, often eco-dependent, e.g. tick-borne diseases (very important).

Control requirements are multi-factorial, and changes in land use can greatly influence these diseases.

(c) group 3

Largely independent of the ecozone and their importance increases as production systems are intensified. Low mortality, multi-factorial, solutions are based on the application of known technical solutions.

For instance, foot and leg problems, reproduction diseases.

(2)

The control and/or eradication of infectious diseases involves more than making a good vaccine (prevention) or drug (control). Moreover, non-infectious diseases and diseases related with management begin to play a more important role with intensification of livestock production.

Animal health aspects have to be regarded as increasingly important. They are strongly interlinked with feeding, breeding, management, housing and the type of farmer. These interactions need more recognition.

Copies of Western-styled solutions are rarely suitable without major modifications.

(3)

Zero grazing or stall feeding.

Farmers in the (sub)tropics, due to pressure from agriculture and increased population are forced more and more towards a form of zero grazing despite the fact that it involves extra labour and other costs. Zero grazing becomes more and more important around (large) towns.

Stall feeding normally leads to less feed and water offered, with less variability and possible selection, leading to a lower intake. Exercise may help in this respect: sunlight, good for hooves and good for calving.

The health merits of zero grazing: protection from direct harmful effects (too much heat, rain, wind, ticks and tsetsefly, worms and flukes). But if stall fed cows are left out to graze, acute diseases may occur.

On the other hand, most smallholder stables experience an increased incidence of diseases (lungs, intestinal, udder, claws and reproduction disorders). Because of closer animal contact, poor ventilation, dust, muddiness, lack of proper bedding and cleanliness, and general poor hygiene around milking and calving. Mastitis and uterine infections are common.

Keeping out predators and thieves, the reduced burden of day to day herding and the production of farmyard manure are other aspects of stall feeding.

(4)

From a Ministry of Agriculture report on cattle diseases in Uganda (1997), *as illustration.*

There have been outbreaks of major diseases like CBPP, FMD, sleeping sickness (nagana), rinderpest and tick-borne diseases. There are vaccinations against rinderpest, CBPP, anthrax, blackquarter and lumpy skin disease.

'Dipping' against tick-borne diseases used to be common practice in the past; nowadays acaricides are expensive (no more subsidies) and resistance has developed. Consequently tick-borne diseases are rising again.
Especially rinderpest and CBBP reappear if there is no vaccination.

5 Calf rearing

5.1 Introduction

Calf rearing is a very important part of running a dairy farm. Owners and managers should always remember that 'today's calf is tomorrow's cow'. A poor calf will never become a good cow.

Many problems may arise in calf rearing and losses during the first two months can be heavy. For example, average calf losses in certain areas may be about 20%, with some farms losing as much as 50% of their calf crop (including still-born calves).

A high mortality rate is a considerable economic loss to the farmer and for that reason close attention should be paid to correct assistance at birth and to the health of the calves during the rearing period.

As far as health is concerned, one should realize that **prevention is better than cure**. A generous application of drugs is **not** the right way to deal with health problems.

Prevention starts by **observing strict hygiene** during and after birth.

The purpose of good calf rearing should be to obtain:

- a healthy and vigorous cow
- a cow with a good capacity for taking in feed, especially roughage
- a long-living cow
- a cow which produces its first calf at an age of 2-2½ years.

Of course, economic considerations should also come into the picture in the rearing of calves: what does it cost to improve the present method of calf rearing and what will be its financial benefits?

Sometimes specialized farms undertake calf rearing for other farms if this is found to be mutually profitable.

5.2 Calving

The rearing of the calf starts soon after the most suitable sire has been selected and the cow fertilized. The correct feeding of the in-calf cow is the right start in rearing the calf.

The gestation period of a cow is about nine months and nine days (with heifers a little shorter).

Two months before the expected calving date, the cow should be dried off. During the 'dry' period, the foetus increases in weight considerably (Friesian breed):

- foetus of 7 months = 10 kg
- foetus of 8 months = 20 kg
- foetus of 9 months = 35-40kg

The cows should calve down in a normal, healthy condition.

The normal calving sequence (refer to '**Reproduction in Dairy Cattle**' in our series):

- 1 to 2 weeks before calving the udder starts to swell
- about one day before calving, the cow should be brought into a disinfected, **clean** and convenient calving box if possible (remember that a large paddock is much better than an infected, dirty calving box!)
- about two hours before birth, the body temperature of the cow will drop a little
- mucus is secreted from the vagina
- finally the cow becomes restless and actual labour starts (action of uterine muscles)
- first the foetal membrane appears, widening the birth canal; it will soon burst

- then the feet membrane shows and the front hooves and nose of the calf appear; labour is now supported by belly muscles
- only if necessary, help the cow, by pulling on the calf **only** when the cow is pressing; pull with care and do not force anything; disinfect hands and use disinfected pulling rope
- if in doubt, seek for professional assistance

Care of the newly-born calf

Immediately after birth, the navel string should be disinfected with iodine solution; this should be repeated 24 hours later.

Calves can be kept with their dams for 12-24 hours to allow suckling, if this is found convenient; a generous amount of colostrum (see below) taken during the first hours gives the calf protection against various infections.

Only healthy calves should be kept for rearing; at least 90% of the female calves born twin to a male, are sterile.

5.3 Feedstuffs

At birth the rumen of a calf is not yet developed: only the fourth stomach (abomasum) functions.

As the calf grows there is a gradual transition until the ruminant digestive system is fully functional, with a well-developed rumen. The calf is now no longer dependent on a milk diet but can consume other feeds as well (grass, for instance).

Rumen development should be stimulated by feeding the young calf an increasing amount of good quality roughage after the first week after birth.

Digestion of starch in the early life of the calf is poor, so starchy diets should be avoided for the young calf.

The most **common feedstuffs** used for calves are:

Colostrum

This is the milk produced by the cow during the first days after calving.

The composition of colostrum is quite different from that of normal milk; colostrum contains less water, more fat and more proteins than normal milk.

Colostrum is important for the following reasons:

- When the calf is born, it has no resistance against pathogenic organisms, so the calf is very vulnerable after birth. By feeding on colostrum the calf ingests globulins (= protein molecules with 'antibodies', see chapter 2) which pass directly through the intestinal wall into the bloodstream (they are not broken down). This only occurs until about 36 hours after birth, and, in particular, during the first 12 hours after birth. These proteins with antibodies give the calf resistance to the common pathogenic micro-organisms in its environment.
- Colostrum milk contains substances which expel the contents of the intestinal tract at birth and activate its functioning (which is desirable).
- Colostrum milk contains a large amount of easily digestible nutrients and minerals.

If there is no natural suckling, the first feeding of colostrum milk should be given very soon after birth; colostrum can be fed within the first half hour of life! The calf should get colostrum several times a day (say, 4-5 times). This may not be convenient (labour!) and that is why the following feeding practice is often applied (with the calves in cubicles): put colostrum in a clean teat-bucket and fix this bucket at a height of about 70 cm. The calf can now feed whenever it wants to. The first time it may be necessary to help the calf to find the teat of the bucket.

It is not a problem if the colostrum cools down in the bucket, but colostrum should be put in the bucket twice a day and the bucket should be thoroughly cleaned before each filling.

This practice is less labour-demanding and assures a maximum intake of colostrum, which will make the calf grow vigorously and which will have a positive effect on the health of the calf.

Most calves will consume about 4-6 kg of colostrum per day if all is well.

The colostrum milk should not be given mixed with normal milk and should never be warmed up after standing for a while.

The colostrum period should last three days at least. After that, a gradual change to milk replacer can start; lower the amount of colostrum every day and mix it with increasing amounts of milk replacer. However, the change to milk replacer may wait until the second week after birth.

Another method of feeding colostrum milk to the calf in sufficient amounts is to leave the calf with the cow for 1-3 days. During this period the cow should also be milked to stimulate milk production and to evacuate excess colostrum.

Whole milk

This is a rather uneconomic feedstuff but unless skimmed milk or milk replacer is available, it is indispensable for at least 5-6 weeks.

Skimmed milk

Skimmed milk is milk from which most of the fat has been removed. It is an ideal feedstuff for calves and is normally cheap.

Whey

Whey is a by-product of cheesemaking. It is excellent for calves but it should **not** be used before calves are at least 5-6 weeks old.

Milk replacer

When using milk replacer, be sure to **follow the manufacturer's instructions** on mixing the milk replacer with water.

Milk replacer should be of high quality. This means that it should be made of high quality products for calves, such as skimmed milk powder and casein (milk protein).

Milk replacer should contain at least 20% crude protein.

The fat content of milk replacers may vary from 3 to about 25%; 12-15% is the recommended level for feeding calves.

High levels of crude fibre indicate that grains (meal) have been added to the milk replacer. This means a low quality milk replacer as calves cannot digest such replacers well. A good milk replacer never contains more than 1% of crude fibre.

Carbohydrates should consist of milk sugar (lactose) and not of starch, as young calves cannot digest starch well.

In many countries the addition of antibiotics is permitted/recommended; in other countries this may be controversial.

The addition of extra amounts of vitamin A, D, E and B 12 is good practice and is often done by replacer manufacturers.

A milk replacer should stay in suspension and **not** settle when mixed with water. Preferably use warm water when mixing replacer with water.

Poor quality milk replacer results in poor growth of calves and increased incidence of scour.

A good milk replacer suits calves just as well as whole milk and is cheaper than whole milk (per kg dry matter). However, it is not available everywhere.

Concentrate

This is a very important feedstuff for calves and it is normally cheaper than whole milk.

For that reason the minimum amount of milk should be used in calf rearing and concentrate feed should be given from an early age. Concentrate feeding should start from the second week onwards

and should be supplied freely for the first 2-3 months. Fresh concentrate should be given every day and not in one amount which lasts for a few days, as the concentrate will become less palatable and the calves may reject it.

Concentrate for calves, usually called **calf starter**, should be very palatable, low in crude fibre and high in protein (at least 15-20%).

Again, calf starter may not be available everywhere. In that case, seek local advice for a proper formula.

Roughage

As roughage is the future staple feed of the calf, it should get used to it as soon as possible. The roughage can be hay, silage or any kind of high quality green feed.

Water

Last but not least: **water**. Indispensable, especially during hot weather. It should be clean and fresh. Always 'ad libitum', that is to say the calf should drink whenever it wants to.

Note:

There is a great deal of variation in the amounts of feed recommended in calf feeding.

When taking decisions about how to feed the calves, a farmer should be guided by two things:

- 1 **realisation of a daily growth rate of 400-600 grams (depending on the breed) and**
- 2 **achieving this as cheaply as possible.**

In bucket-rearing the schedule for the first week is normally as follows:

- 1st day to 2nd day ad libitum colostrum
- 3rd to 4th day 3-4 kg of milk per day
- 5th to 7th day 4-5 kg of milk per day depending on breed

5.4 Calf rearing methods

Single suckling

The calf stays with the mother cow until weaning. This method is commonly used in beef production schemes.

A problem is that cows may not come in heat early enough and this results in a longer calving interval.

Multiple suckling (nurse cow)

One (high yielding) cow can be used to suckle 2-4 calves, in consecutive batches, for the entire duration of the lactation period. This saves labour.

A difficulty is that the nurse cow may not accept foster calves.

Partial suckling (restricted suckling)

The calf stays with the mother **for a limited time**, normally no longer than a few days. During this time the calf gets the necessary colostrum directly from the cow and it can have as much as it wants.

An advantage is that there are few problems as far as hygiene is concerned. It is also an easy method and gives good results. However, there are problems sometimes when it comes to accustoming the calf to the bucket, after weaning. If this is a serious problem, the calves should not stay longer than 24 hours with the mother.

Another form of partial suckling is when the calf is allowed to feed at the udder of the mother cow **a few times a day**, whilst the rest of the milk is removed by the milker. This goes on until weaning.

In tropical (dairy) breeds the calf may be needed to stimulate milk letdown.

A great problem is that one cannot check the amount of milk that the calf drinks; allowing the calf to drink too much costs money! Admittedly, this method has its attractions especially for the farmer who owns only a few cows.

Artificial calf rearing (bucket rearing)

Immediately after birth the calf is separated from the mother and put into a pen. The calf is given colostrum but this is fed in a bucket.

This method gives good results provided that the farmer pays a lot of attention to **cleanliness** of bucket and pen and ensures that the right feeds are served, in correct amounts. Under poor conditions artificial rearing may result in very heavy calf losses, say 50% or even more. In such cases changing to partial suckling may considerably improve the situation.

The advantages of artificial rearing are that one knows exactly how much feed the calf consumes and that milk can be substituted for a cheaper product. However, artificial calf rearing requires a **high management level** and is rather labour-demanding.

The following **two** feeding programmes have given good results, with Friesian cows, in East Africa:

Table 1:

| week | whole milk | concentrate | roughage |
|-----------|--------------|-------------|---|
| 2nd | 5 litres/day | handful | a little good hay or a mixture of sorghum, lucerne and napier grass, slowly increasing |
| 3rd | " | " | |
| 4th | 6 l/day | ½ kg | |
| 5th | " | " | |
| 6th | " | " | |
| 7th | 5 l/day | 1 kg | |
| 8th | " | " | |
| 9th | 4 l/day | " | |
| 10th | 3 l/day | " | |
| 11th | " | " | |
| 12th | 2 l/day | 1½ kg | |
| 13th-40th | nil | 1½ kg | |

Note:

If **scouring** tends to become too troublesome, or if the calves are of light breeds, the amounts of milk can be reduced.

From the second week, roughage and fresh water should always be available.

During the first 12 weeks the concentrate is 'early weaner pellets' (whatever the milling industry calls them), and afterwards 'young stock pencils', or the like, can be used.

In the above case the total per calf for 40 weeks is 350 litres of whole milk, 55 kg of early weaner pellets and 285 kg of young stock pencils.

The second feeding programme is as follows:

Table 2:

| week | whole milk | skimmed milk | concentrate | roughage |
|-----------|--------------|--------------|-------------|---|
| 2nd | 5 litres/day | | handful | |
| 3rd | 4 l/day | 1 litre/day | „ | |
| 4th | 3 l/day | 3 l/day | ½ kg | |
| 5th | 5 l/day | 5 l/day | „ | |
| 6th | 1 l/day | 6 l/day | „ | |
| 7th | 1 l/day | „ | „ | |
| 8th | | „ | 1 kg | |
| 9th | | „ | „ | |
| 10th | nil | „ | „ | a little good hay or a mixture of lucerne, sorghum and napier grass, slowly increasing |
| 11th | | „ | „ | |
| 12th | | 5 l/day | „ | |
| 13th | | „ | „ | |
| 14th | | „ | „ | |
| 15th | | „ | „ | |
| 16th | | 4 l/day | 1½ kg | |
| 17th | | 3 l/day | „ | |
| 18th | | 3 l/day | „ | |
| 19th-40th | | nil | „ | |

In both cases, after two weeks **water** should be freely available (no limits).

The total of 40 weeks is 112 litres of whole milk, 525 litres of skimmed milk, 50 kg of early weaner pellets and 220 kg of young stock pencils (from 12 weeks).

Naturally **there are many other good feeding programmes. The above tables are only examples.** Quite a few people may rightly think that the amounts of milk fed to the calves in these examples are excessive.

Other remarks:

- Calves should be taught to drink out of a bucket.
Feeding twice daily is satisfactory.
Sudden, significant changes in both the amount and type of feed should always be avoided.
- When using artificial milk powder (or replacer), the **solubility** of the product is an important point; the product should be dissolved following the instructions of the supplier.
- **Always keep a close eye on the calves.** They should always drink their milk quickly; if not, then the calf is not well and the milk should be taken away.
- The calves should feel 'comfortable'. Avoid colds and draughts, cold and wet floors (little bedding, on concrete), a sudden supply of cold milk.
- Other easily visible health signs are: glossiness of the hair, liveliness of the calf, colour of the calf, colour and consistence of the droppings.

5.5 Calf diseases

Diarrhoea (scours)

Calf diarrhoea may be caused by various viruses and bacteria. Early feeding of colostrum is the best preventive, along with isolating a calf after birth (in a disinfected, clean cubicle) and preventing draughts. Dipping the newly-born calf's navel (umbilical cord) in iodine is also important. Use clean utensils and keep the calf area clean and disinfected.

Do not overfeed the calves as this may also cause scours.

Poor quality milk replacer may also cause problems.

If a calf develops scours, **early detection** is important and treatment should begin as soon as the first symptoms (loose faeces) are noticed. Do not wait until the next feeding.

Symptoms of scours are:

- strong smell of the faeces
- the faeces are liquid and have a whitish colour
- buttocks and anus are dirty
- the calf appears dull

Not feeding milk or milk replacer for one or two feedings is quite helpful in many cases.

Instead of feeding milk, boiled water should be given, at body temperature. It is good practice to add one teaspoonful of baking soda and one teaspoon of salt to the water and, if available, some dextrose. The salt is added to replace the salts lost during scouring.

If no improvement is seen after a day, it will be necessary to contact a veterinarian, possibly for some medication (antibiotics).

During scouring a calf loses a lot of liquid and there is a risk that the calf **dehydrates** and becomes very weak.

An easy test for dehydration is to pinch the calf's skin gently along its neck or rear leg and see if the skin returns quickly to normal or if it remains in a fold for a few seconds.

If it stays in a fold for a few seconds, dehydration is present and extra liquid has to be provided. If the calf is too weak to drink, liquid should be forced into the calf by using a bottle.

If scouring lasts longer than one day, the calf should receive some feed as its body reserves are not sufficient for it to go without feed for two days.

If dextrose can be provided during the first day, then the same treatment with boiled water, dextrose, salt and baking soda can be continued for one more feeding, taking care that extra amounts of this mixture are given during the second day to make up for the loss of water and salts during scours.

If, after one day, some improvement is seen (the calf looks stronger, is more lively), some milk or milk replacer can be given (about the normal amount), but still with the addition of a little salt and (if available and if necessary) an antibiotic.

Take care that boiled water is available to the calf at all times and if the calf will not willingly drink, water should be forced upon it by bottle.

However, if the calf's condition becomes very serious and if it is unable to rise and has sunken eyes, veterinary help is needed to give the calf intravenous fluids and salts, otherwise the calf will most likely die.

If scours have been detected in an early stage and if prompt treatment is started, in many cases the calf will recover after a day or two.

Calf pneumonia ('clinical respiratory disease')

Although bacteria and viruses may be involved in pneumonia, several external factors like draught, chilling, dampness, high humidity and poor ventilation of the calf area, increase the risk considerably of getting pneumonia.

Calves are most susceptible just after weaning until 5-6 months of age.

Symptoms may include coughing accompanied by a running nose and watery eyes. In most cases there is a high fever (40-41½ °C).

Unfortunately, a rather high percentage of calves with pneumonia usually die, even after treatment.

Early treatment with antibiotics by a veterinarian gives the best results.

Because the calf's environment can contribute so much to respiratory health, it is very important to keep the calf area draught-free and to prevent strong manure/urine odours (proper ventilation!).

Paratyphoid

Paratyphoid is caused by the bacterium *Salmonella dublin* and can easily be recognized, because the body temperature of the calf rises to 41-42 °C.

Treatment with an antibiotic is necessary.

The calf should be separated from the other calves and the whole calf shed should be disinfected.

5.6 Housing

The way calves should be housed depends mainly on the climate. The colder the climate, the more attention should be paid to housing.

There are different ways to feed calves:

- individual feeding in separate pens
- group feeding

Although both ways have proved to be successful, success depends first of all on proper care, by the farmer or his personnel, and the way the calves are housed. It is important to know that calves are far more sensitive to draught than to cold.

Individual pens

With individual pens it is easier to watch the calf (health!) and the risk of contagious diseases is reduced.

Particulars:

- the individual pens can be movable pens
- the pens should be enclosed with 3 draught-proof walls
- each pen should have 1 to 1½ m² of floor space
- the floor of the pen should be well drained; if possible clean bedding should be provided every day
- there should be troughs for water, concentrate and roughage
- the calf should stay in the pen for at least 10 weeks, after which it can be allowed to stay outdoors during the day

If they are to serve their purpose, the walls of the pens should be impervious to prevent nose-to-nose contact and contamination by dung and urine. They should be constructed of a material which allows thorough cleaning and disinfection between calves; sheet metal or plywood is quite suitable.

The above material is usually quite expensive in the (sub)tropics. A cheap and satisfactory alternative is to tether the calf in a pen which is about 60 cm wide and open at the back. Dung and urine always pass to the rear rather than to the walls of the pen, the next pen or the feed and water buckets.

Such pens can be constructed very cheaply because the walls do not need to be made of impervious materials. Less bedding is required because only the bedding at the rear of the bed is fouled. They can be raised 20 cm from the ground to keep them drier.

group feeding

With group feeding it is less easy to watch the individual calf but feeding is easier.

Particulars:

- calves are kept in groups of 6 to 8 calves
- each calf should have about 2 m² of floor space
- the floor should be well drained; if possible clean bedding should be supplied every day, or a slatted floor should be used
- troughs for water, concentrate and roughage should be installed
- after weaning, the calves can be kept outdoors, separated from older animals; water and concentrate should be available
- concentrate should be given up to the age of 9 to 12 months, depending on growth and live weight

With group feeding, self-sucking or the sucking of another calf's udder or navel can be a problem. This is why keeping the calves separated, in individual cubicles, until weaning is completed, is sometimes preferred to group feeding.

Teaching the calves to drink from a bucket when 2-3 days old and avoiding prolonged use of teat buckets (when group feeding) may help in reducing the sucking habit somewhat, but there is no guarantee that the habit will not occur.

5.7 Grazing

Having been weaned, the calves are supposed to get their feed mainly from grazing (roughage); remember that the best grazing is hardly good enough for calves of this age!!

There are several ways to graze the calves:

- they graze ahead of the cows
- they have their own paddocks (a different paddock every 10 days)
- they are tethered and are moved to clean grass every day

On large farms, the first and second method are the most convenient ones. On smallholdings, the last method is a good and practical method, if no other animals are grazing the same area.

Young calves should be kept out of the main grazing areas of older animals, because **young calves are very susceptible to worm infection**. The best method for the smallholder dairy farmer seems to be to tether the calf to clean grass during daytime and have it indoors at night, during which time the calf should get some **concentrate** and hay.

If no concentrate is available, very good fodder should be mixed (for instance, young napier grass, sorghum, setaria, lucerne) and given to the calf.

Up to the age of 9-12 months, the calf should be kept and fed in this way, in order to get a healthy, vigorous heifer that calves down as early as possible (2 to 2½ years old).

5.8 Special treatments during the rearing period

Dehorning or debudding

There are different methods of dehorning a calf; all are successful, depending on the experience and skill of the operator rather than on the method used:

With caustic potash

This should be done within the first week of the life of the calf.

When applying caustic potash, contact with the human skin should be avoided and, after treatment, suckling cows should be kept away from the calf.

Steps:

- clip the hair of an area about 2½ cm in diameter, over the rudimentary horns
- spread a little heavy grease (milking jelly) around the outer edge of this area, to prevent the caustic potash from running into the eyes of the calf
- after treatment, do not let the calf go outdoors when the weather is rainy
- the stick (caustic potash) is rubbed on the skin area immediately over the horn until the hair is removed and the skin becomes red (for about 15 seconds); leave the calf alone (without other calves or cows) for at least one day

With flexible collodion solution

This should be applied within two days after birth.

Steps:

- clip the hair of the horn area
- clean this area with spirit to remove fatty covering
- apply a little collodion, with a small brush, and rub it in
- apply a second time without rubbing the collodion in
- after 48 hours, check whether the collodion film is still present; if not, repeat the treatment

With a hot iron (electrical or charcoal)

This should be done 2 to 3 weeks after the birth of the calf. It is a very good method.

Steps:

- clip the hair of the horn area
- place the heated iron on the horn button, at short intervals, for 5 to 10 seconds each time
- heating is continued until the colour of the tissue around the base of the horn button turns to deep copper
- the heat will kill the growth cells

With a rubber ring (elastrator)

This method is used when the horns have already developed and it is too late to apply other methods.

5.9 Results of good calf rearing

It is repeated that the main purpose of good calf rearing is to get healthy, vigorous heifers which calve down at the age of 2 to 2½ years (for the first time). This means that the heifer should be served at the age of 15-21 months, depending on the breed of the heifer. The daily growth rate from birth up to first service should be at least 500 gram.

With the following table it is possible to calculate the growth rate of young calves:

Table 3:

| Girth | Live weight (kg) |
|--------|------------------|
| 65 cm | 28 |
| 70 cm | 34 |
| 75 cm | 41 |
| 80 cm | 49 |
| 85 cm | 58 |
| 90 cm | 68 |
| 95 cm | 79 |
| 100 cm | 91 |
| 105 cm | 104 |
| 110 cm | 118 |

Take as an example a calf born on 1st October; its girth is then 73 cm, which corresponds with a live weight of 38 kg.

On 18th November of the same year, the calf is measured again; the girth is now 87 cm which corresponds with a live weight of 62 kg.

The gain is 24 kg and this has been reached in 47 days; therefore the daily growth weight has been:

$$\frac{24,000}{47} = 511 \text{ gram}$$

The above table is valid for most breeds up to a girth of about 100 cm.

Above 100 cm, it is no longer very accurate, because each breed grows to its own 'specifications'.

Naturally, the time of first service does not only depend on body weight or on age, it is normally a combination of various factors.

The main factors are:

- Breed; Bos indicus breeds are later-maturing than Bos taurus breeds.
Of Bos taurus breeds, the Jersey is earlier-maturing than the Friesian.
- Body weight.
- Age.

At the time of the first service, the heifer should have a body weight of approximately $\frac{1}{2}$ to $\frac{2}{3}$ of the breed's mature weight.

The following table indicates the desired body weight for various breeds of cattle, at the time of the first service. The aim should be to reach this body weight at the age shown in the table:

Table 4:

| Breed | Live weight (kg) | Age |
|----------|------------------|--------------|
| Friesian | 300 (at least) | 18-21 months |
| Ayrshire | 275 | 18-21 months |
| Guernsey | 250 | 15-18 months |
| Jersey | 250 | 15-18 months |
| Sahiwal | 250 | 24-30 months |
| Boran | 250 | 24-30 months |

6 Herd administration

On every dairy farm there should be data on the cows which the farmer should have on hand; for instance, age, last calving date, insemination/mating date and date of drying off.

On small farms this is not a problem; the farmer usually knows his/her cows and easily remembers the particulars of each individual cow. Literacy and numeracy is of great help of course; in fact 'modern dairy farming' is almost unthinkable without abilities to read/write and make simple calculations.

The owner or manager of a large farm, however, will have problems in remembering the particulars of each individual cow and he will need a way to have these particulars available daily, when he is among his cows.

Another problem is that on large farms the cows are not known by name.

In order to keep accurate records, a means of identifying individual cows should be established.

6.1 Cow identification

The method of identification has to be cheap and easy to apply.

On the other hand, the identification mark should be permanent and easy to read, even from a distance. The identification mark should also be legible in different situations, for example, during grazing, dipping and milking.

There are several ways of marking a cow and a method should be selected which is most suitable for the farm in question:

➤ **A sketch** (drawing or marks) or a **picture** of the cow. It can be made of each young animal in the herd.

It is considered a rather inefficient way to identify cows; it is very difficult to apply when the animals are whole-coloured.

➤ **Branding**. Mainly used on beef cattle. Branding can be applied to adult stock only. On black cattle branding is not very legible. Branding reduces the value of the hide considerably.

➤ **Freeze-branding**. This method makes use of liquid nitrogen of minus 190 °C. The identification number should be applied on the coloured parts of the skin. On white animals the number does not show. With this method the hide is not damaged (only the pigment is removed).

➤ **Ear-tattooing**. Figures and/or letters are tattooed in the inside of the ear of the cow, with special equipment (tattooing forceps). Unless properly done, the tattoo mark may tend to fade. The cow has to be restrained when one wants to read the tattoo mark, which is inconvenient.

➤ **Ear-notching**. This is a simple method of identification, provided that a 'code' is used. A disadvantage is that the 'numbers' are difficult to read from a distance.

There are many different codes; the following is generally accepted by farmers:

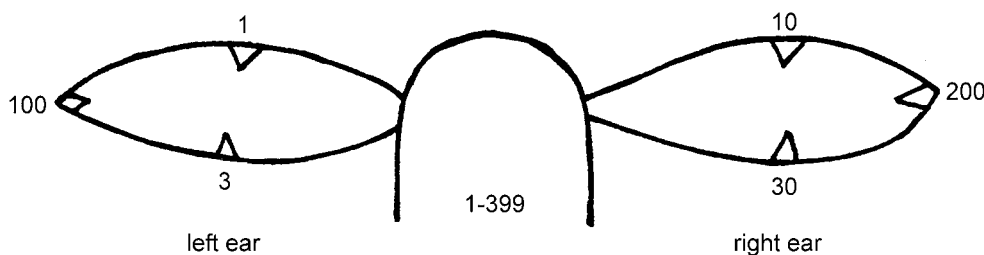

Figure 4:

With the above code, numbering is possible in the range of 1 to 399. Each notch has a specific meaning, as indicated.

When reading or when making notches, always stay on the animal's left side, behind the ears.

Never put more than two notches in the upper edges of the ear and more than three in the lower edges.

- **Tags.** There are several makes of tags, metal as well as plastic ones. Each kind of tag has its own applicator, for the ears or for the tail or legs. Tags are fairly effective but they may get lost under certain circumstances.
- **Neckstrap.** The neckstrap (collar) made of plastic is a simple but rather expensive way of identification. Under certain circumstances (hot sun, spraying/dipping), the plastic becomes hard and may break.
- **Chain collar with number plate.** Simple and fairly cheap. It is for multiple use. If the chain is very strong the animal may hang itself under certain circumstances.

6.2 Farm records

As stated before, the herd's complete records are not very helpful in the day-to-day management of the herd. The farmer (or his personnel) will need an aid to memory, on which to base instant decisions when he is among the cows. There are several possibilities:

Reproduction card

On this card the farmer can note down particulars of individual cows. When such a card is filled in properly, the farmer has many useful facts on hand about a particular cow. Such facts are: expected calving date, calving problems, uterus infection, heats, inseminations or servings, diseases and treatments and other facts a farmer wants to note down for future reference.

Cow calendar

The cow calendar gives information about reproduction matters at a glance. It should be installed near the cows: farm office, dairy room, a store or any other convenient place.

Below follows a description of the **disk model**, with revolving disk and with fixed indicators. It can be made locally; see illustration.

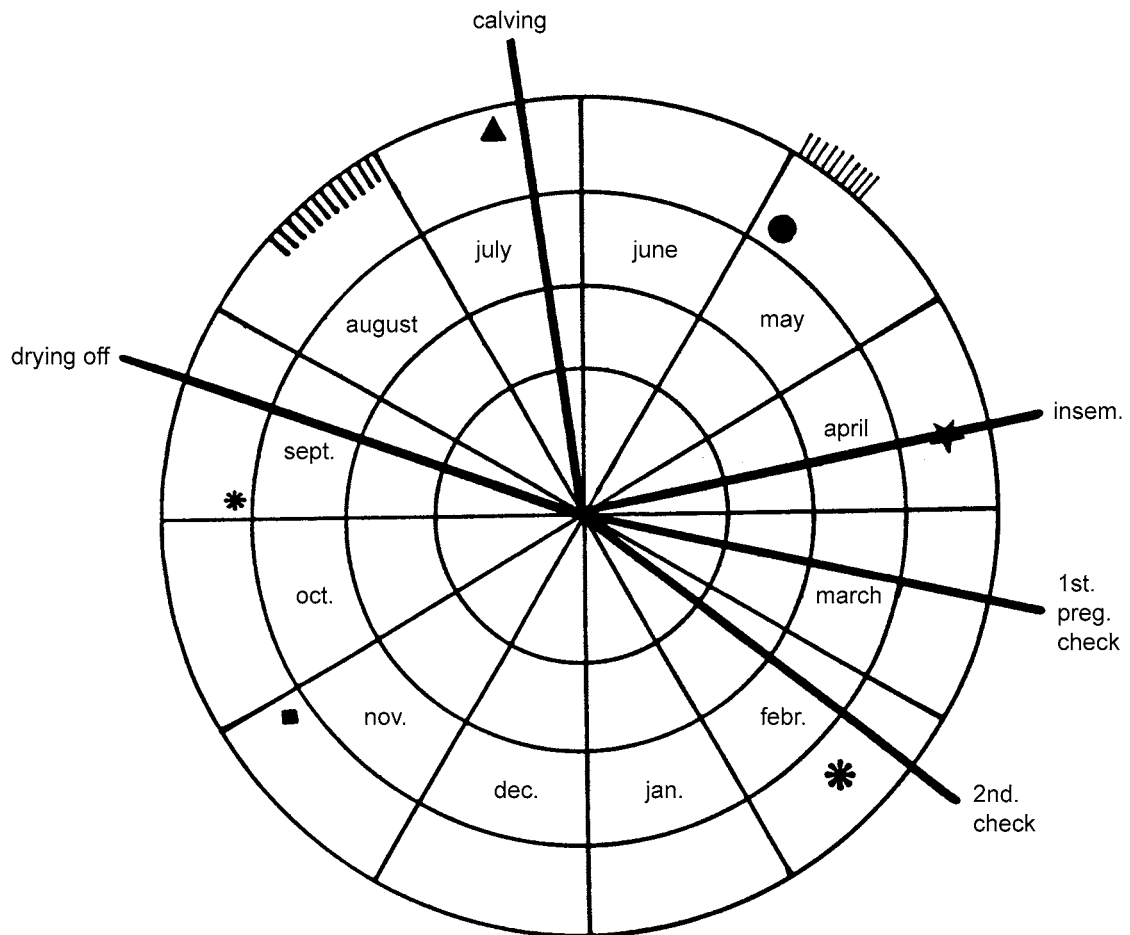

Figure 5: Disk model cow calendar

The disk is divided into 12 sections. Each section represents one month and is sub-divided into days. The fixed indicators indicate successively:

- the insemination date (or date of natural service)
- the date on which pregnancy has to be checked (21 days after the insemination date)
- the date of drying off (7 months after the insemination date)
- the (expected) calving date (9 months after the insemination date)
- sometimes a second pregnancy check indicator is used (6 weeks after the insemination date).

The use of the disk model cow calendar is explained in our guide 'Reproduction in Dairy Cattle', book 2. It should be remembered that the cow calendar is a relatively sophisticated tool; quite often a simple card system will be more appropriate.

Other aids which can be used by the farmer are, for instance, the 'daily note book'. It is to be filled in by the farmer as well as by the vet when he visits the farm, the tractor driver, crop manager and other persons dealing with the farm.

Later on, all relevant data are entered on individual record cards of cows and on other farm records.

6.3 Office records

So far only records for use 'among the cows' have been discussed.

These records mainly concern reproduction and health and only cover one year or one lactation period.

Normally a farmer wants to have a **complete** record of each individual cow, covering the whole life-time of the animal. Such record cards (the number of which equals the total number of cows on the farm) can be kept in a box in the farm office.

Many data can be entered on the individual record cards; for instance:

- (name and) number of the animal
- birth date
- pedigree
- calving dates and reproductive performance
- calves born
- diseases and treatments
- production figures
- other data that might be useful to retain

As soon as a calf is born, or a calf or cow bought, and kept on the farm, a new card should be started. Ideally, every week all new data should be entered on the individual record cards.

These records are necessary for making the right decisions concerning breeding, culling and other matters.

Other cow records a farmer may possibly have to deal with are:

- milk recording forms
- artificial insemination records; insemination plan
- herdbook administration
- health administration for official purposes

Apart from records concerning the calves and cows, there are **other important records**:

- grassland use and grazing plan
- feed conservation plan
- roughage control
- stock of concentrates

and, most importantly,

- financial data ('farm accounting') and economic administration (how successful is the farm, financially speaking)

N.B.

Reproductive records are also dealt with in our guide *Reproduction in Dairy Cattle* (2 vols.).

The AGROMISA guides 'The Farm as a Commercial Enterprise' (latest edition 2003; 110 pages) and 'Farm Accounting' (2003; 50 pages) deal with financial-economic aspects of dairy farming.

7 Housing of dairy cattle

7.1 The climate

The local climate is a combination of factors which include temperature, rainfall, humidity, sunshine and wind.

The climate affects dairy cattle in two ways:

- direct effect on the cows
- indirect effect on the cows' environment

Thermoregulation

A cow absorbs heat from direct or from indirect sunshine. The digestion of feed also produces heat. The above heat **gains** must be counterbalanced by heat **losses**, if the body temperature of the cow is to remain the same.

The cow loses heat to its environment by;

- radiation, convection and conduction
- evaporation of water through sweating and panting

Cows try to regulate their rate of heat loss so as to maintain a (constant) body temperature of 38-39 °C.

Within a certain air temperature range (the 'neutral zone') regulating the body temperature is not so difficult for a cow: a greater or smaller blood flow to the skin, more or less evaporation of water from the skin and the lungs and changes of posture, are things that the cow can do herself.

At temperatures **below** this neutral zone the cow has to eat more, which means extra feed just for body temperature maintenance.

Above the neutral zone the cow is likely **to eat less**, in order to decrease heat production from the digestive process. In other words, if the air temperature rises above a 'critical' temperature, the cow will reduce her feed intake. Digestion will then produce less heat and this will diminish the heat problem for the cow. But the cow will also **produce less milk!** and this is not what a farmer likes.

The critical air temperature is said to vary from 25 to 35 °C, mainly depending on production level and breed.

European breeds have higher production levels and higher digestion rates than tropical breeds. Therefore the feed intake of European cattle diminishes at lower air temperatures than the feed intake of tropical cattle; examples:

- with Friesian cows at 24-27 °C
- with Jersey and Brown Swiss cows the decrease starts at 26-29 °C
- with Brahmans it starts at 32-35 °C

Boran cattle are reputed to have a superior heat tolerance compared with other breeds.

Dry cows require less feed than lactating cows and as the air temperature rises their feed intake does not diminish so rapidly.

Increasing humidity and intensive sunshine also tend to depress the intake of feed.

Cows, especially European breeds, may not like grazing in the heat of the day. Whenever possible, cows should be allowed to graze at night, especially when the quantity and the quality of the available feed is poor.

Housing the cows will decrease heat production. Maintenance requirements will be reduced by about 20%.

Walking long distances for drinking water will markedly **increase** the maintenance requirements.

Peaks in heat production occur 2 to 3 hours after feeding. In hot weather it is therefore advisable to feed supplementary feedstuffs in the early morning or late in the afternoon and to encourage grazing during the cooler hours.

A reduction in feed intake because of heat may be recovered partially by using more concentrated feedstuffs. Cows on a low crude fibre diet produce less heat and more milk than cows on a high crude fibre diet.

Fertility

High air temperatures also tend to depress **fertility**:

- it takes more time for cattle to become sexually mature
- oestrus (= heat) periods become shorter
- more temporary fertility, more 'silent heats' and more embryonic deaths

Moreover, signs of oestrus are less clear in heat-stressed cows. Bulls may show less libido and the quality of their semen may decline.

Remember that many of the effects of high air temperature on reproduction may in fact be the result of low feed intakes.

Modifying cold conditions

In some areas in the (sub)tropics, night temperatures may be so low as to affect the survival of newly-born calves.

Calves should first of all be protected from **draughts** in order to prevent respiratory disorders. Usually semi-open boxes or buildings with outer walls from 1 to 1½ metres high, give sufficient protection against cold weather and draughts.

Modifying hot conditions

When air temperatures are often above 25 °C, it makes sense to consider modifying the 'heat load' on the cows. In particular when production levels are high and when there is little wind, a lot of sunshine and a high relative humidity. In this situation one should always ask oneself: what does a certain measure cost and what will be its benefit?

Shading and (artificial) **cooling** are measures that may be considered.

Radiant heat 'falls' on the animals from all directions but mainly from above.

Bare soil produces a greater heat load than a pasture.

Per adult cow a shaded area of about 5-6 m² is the minimum that is required and the shade should be 3-4 m high.

The orientation of the shade is a point to consider; for instance, should the orientation of a roof be East-West or North-South?

The kind of roofing material is also a point to consider. All shading materials are better than no shade. However, thatched roofs are most effective because they insulate well and they reflect the light of the sun.

Aluminium and galvanized iron roofs are also suitable. Extra insulation from leaves, grass or insulation boards placed on the roofing material may be considered.

Trees are very effective but, of course, around noon, when shade is most welcome, the shaded area is smallest.

Cooling by means of water (evaporation) is very efficient. It can be achieved by:

- providing relatively cool drinking water to the animals at all times (storage tanks in the shade; underground piping)
- wetting the animals by sprinklers (during the hottest part of the day)
- providing wallows (think of the buffalo)

Fan cooling for cows is relatively more expensive. Before considering fan cooling, first of all make maximum use of natural ventilation.

Pad-and-fan cooling is even more expensive. The lower the relative humidity of the incoming air, the more effective the cooling. The principle is evaporation of water in the incoming air.

N.B.

The above text on how the climate affects dairy cows has been adapted from an article by H.M.J.Udo, lecturer, Wageningen Agricultural University, in the Netherlands.

7.2 Introduction to the housing of dairy cattle

The following text on the housing of dairy cattle has been prepared by what was formerly called the Institute of Agricultural and Environmental Engineering (IMAG-DLO) of Wageningen in the Netherlands.

Inside their 'houses' the cows should feel reasonably comfortable at all times.

In this respect not only the temperature but also possible chills and draughts (calves!) and ventilation should be taken into consideration.

Of particular importance, too, are surfaces on which the cows have to walk and lie down (foot problems, slippery surfaces, cleanliness).

Structures chosen and building materials used should be both suitable and as cheap as possible.

However, it is not only the climate which has to be taken into account. Designers should also consider things not directly related to the comfort of the cows, e.g. milking, feeding facilities and waste management (including the 'fly aspect').

Particular attention should be paid to the housing of young stock.

Health care of the adult cows and storage of feeds and milk, materials and equipment should also receive attention.

In **hot climates** the following is particularly important:

- sufficient yard space
- plentiful supply of water
- sufficient trough space for each cow
- shade over the feeding as well as over the loafing area
- wire fences instead of walls so as not to restrict air flow
- planting of trees to lower the temperature
- sowing of grass or other forages in the area surrounding the pens (where possible)
- white-painted buildings
- shading of drinking troughs to keep the drinking water as cool as possible

On the following pages, housing systems are described which are commonly applied but this is only a brief description.

Admittedly, these systems have developed in European climates and may not necessarily be quite suited to conditions elsewhere.

Advice: choose designs which take the local climate into account as fully as possible. In fact little may be needed compared with European standards where the climate is not extremely hot. If the climate is extreme, it is obvious that one should try to control the environment only to the extent which is strictly necessary, in order to keep down costs. Try to make use of materials which are readily available locally.

The text deals with the larger dairy farm. If there are just a few cows, seek advice and look for local examples.

7.3 Housing systems

Two main housing systems can be distinguished, namely **tie-up housing** and **loose housing**.

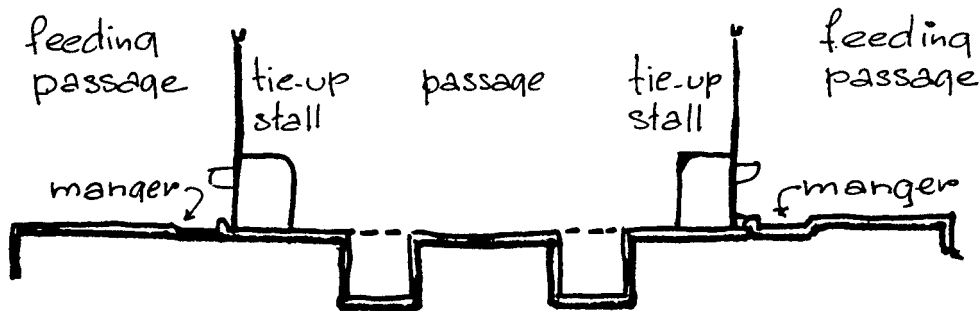

Figure 6: Tie-up housing – tail to tail

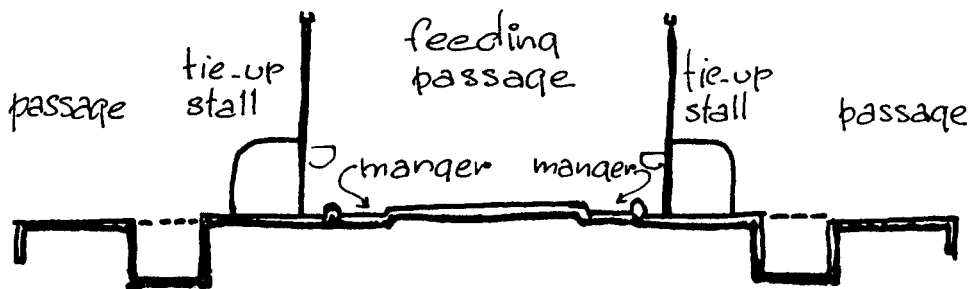

Figure 7: Tie-up housing – head to head

In **tie-up housing** each cow is restrained in a stall. Feed is delivered into a manger in front of the cows. Milking takes place individually in the stall, by hand or by machine (bucket or pipeline milking).

Manure is collected in a gutter.

When cows are tied up all the year round they may get foot (hoof) problems and become stiff.

The detection of heat demands more attention with tied cows than those in loose housing.

A high incidence of trampled teats may be another disadvantage of this type of housing.

In **loose housing** the cows are not tied up, they can walk around freely.

In this type of housing there is usually a loafing area and a lying area, with a feeding area separated from the lying area. The cows are forced to walk frequently.

The manure is spread over a large floor area. The manure can be collected by scraping the dung by hand into a manure pit or a channel. Manure can also be scraped away with a small tractor or with an automated scraper. From the manure pit or channel the manure can be pumped into an outdoor silo or other storage construction.

Milking in this type of housing is usually done in a milking parlour attached to the housing unit or in a separate building. The cows can be milked by hand or by a milking machine.

Feed may be provided in a manger behind a feeding rack with one or more cows per feeding place. It is advisable to have one feeding place for each cow.

Further particulars about tie-up housing

The stalls may be arranged in a single row or in a double row. In a double row arrangement the cows can be stalled facing each other (head-to-head), with a central feeding alley. Figures 6 and 7. The cows can be tied up in the stalls with tie-fittings or tie-chains around their necks. In the latter case the cows have more freedom of movement, but it takes more effort to keep them clean. Manure is collected into a gutter behind the cows. The gutter may be open and shallow. The manure is removed manually or mechanically.

Another possibility for manure handling is deep gutters covered with steel grates, from which the manure can float into a manure pit outdoors. Figures 8 and 9.

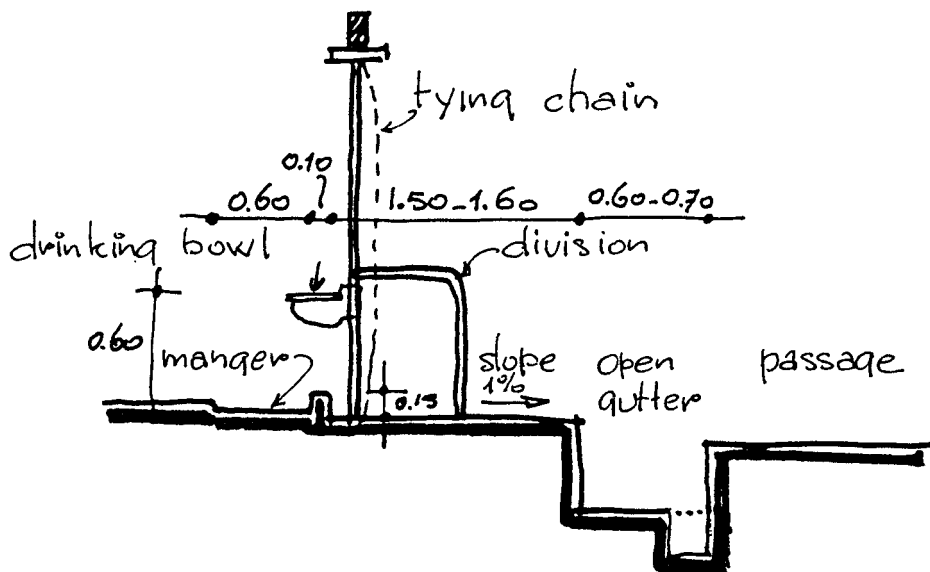

Figure 8: Tie-up stall with open gutter

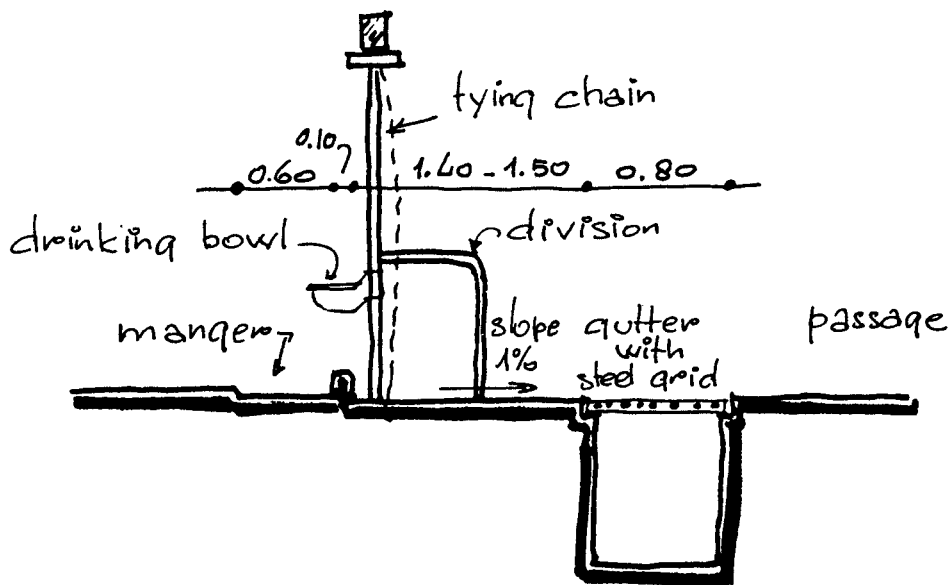

Figure 9: Tie-up stall with covered gutter

The size of the stalls depends on the size of the cows to be housed and on the system of manure removal. The following measurements are used for Holstein-Friesian cows with a weight of 500-600 kg:

Table 5:

| Stall width in metres | stall length in metres | gutter system |
|-----------------------|------------------------|---------------------------|
| 1.10-1.20 | 1.50-1.60 | stall with open gutter |
| 1.10-1.20 | 1.40-1.50 | stall with covered gutter |

The stall size can vary to fit larger or smaller cows.

The cows are usually separated by partitions. When there are no partitions the stall width has to be increased by 50-100 mm.

Drinking bowls are provided at the rate of one per two stalls.

Soft bedding is essential for the comfort of the cow.

Furthermore it keeps the cow clean and helps to prevent hoof problems.

Several types of bedding are used. Stall mats e.g. rubber mats are not uncommon but rather expensive.

The manger in front of the cows has a width of 0.5-0.6 m and is separated from the stall by a curb with rounded edges about 0.15 m high. The bottom of the manger should be at least 40-50 mm higher than the stall level.

Types of loose-housing

Two types of loose-housing can be distinguished:

- loose-housing with a common lying area
- loose-housing with cubicles ('cubicle houses')

Loose-housing with a common lying area

In houses with a common lying area the cows can lie down anywhere. The floor may be an earthen floor and is then usually provided with bedding; in this case the bottom should be well drained.

In dry climates earthen floors without bedding can be used; the dry manure should then be removed frequently.

The loafing area behind the manger with a feeding rack is mostly covered with concrete and should be at least 3 metres wide.

Loose-housing with cubicles – cubicle houses

In a cubicle house the lying area is provided with cubicles. The cows are not tied and for each cow there is a stall which the cows may enter and leave as they please.

Cubicles can be arranged in a single row or in more than one row with a central feeding alley or with feeding alleys along the side walls.

In the case of a double row of cubicles the number of places is matched with those of the feeding rack and they are of the same width.

The cubicles can be arranged with the cows facing one another (head-to-head), or the other way round (tail-to-tail).

With the tail-to-tail arrangement a central loafing alley with a width of 2.20 metres between the cubicles is needed.

If the cubicles are arranged head-to-head, two loafing areas behind each row are necessary. Usually one of the loafing alleys is combined with the feeding alley behind the feeding rack. The total housing area needed in this case is no larger than with the tail-to-tail arrangement.

Figures 10 and 11.

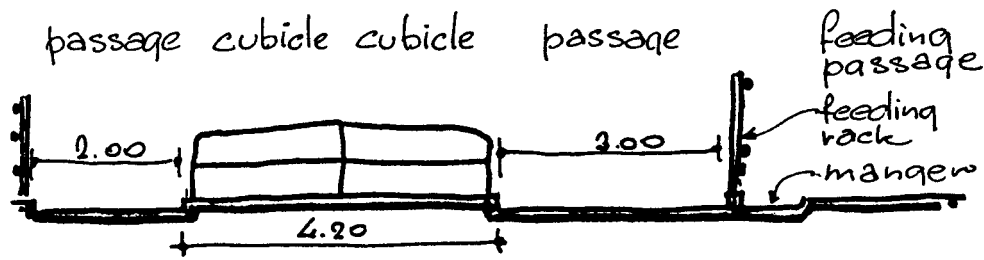

Figure 10: Double row cubicles – head to head

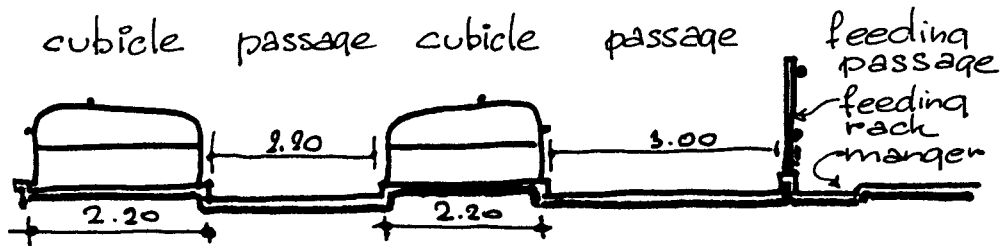

Figure 11: Double row cubicles – tail to tail head to head

The size of the cubicles depends on the size of the cows to be housed. The following measurements are common for Holstein-Friesian cows with a weight of 500-600 kg.

Table 6:

| Arrangement of cubicles | Cubicle width in metres | Cubicle length in metres |
|-------------------------|-------------------------|--------------------------|
| single row | 1.10-1.15 | 2.20 |
| double row | 1.10-1.15 | 4.20 |

The size may differ to fit larger or smaller cows.

The floor of the cubicles can be an earthen floor with a thick layer of bedding, or can be solid, with a soft top layer.

The simplest bedding for cubicles is packed earth or sand. This bedding is inexpensive but needs care in order to maintain a flat surface. Sand is quickly pushed around by cows. Therefore it should not be used with mechanical or liquid manure systems because it fills up storage tanks and it is very abrasive, therefore damaging equipment, eg. manure pumps.

A concrete foundation with a disposable bedding of chopped straw, sawdust, wood shavings or crushed corncobs is more common.

Hard surfaces of cubicles should have a slope of at least 1% so that urine will drain into the alleys.

Figures 12 and 13.

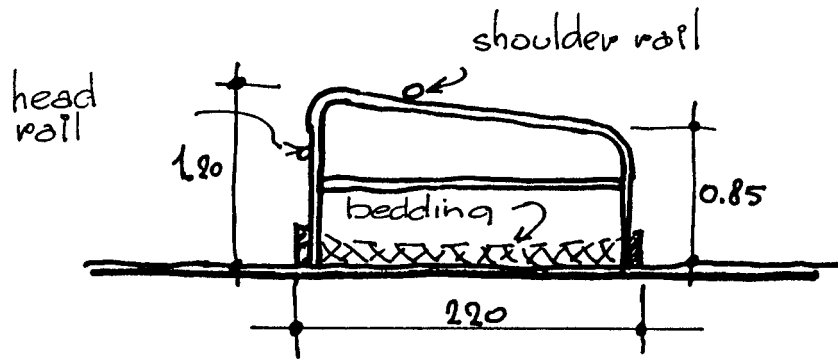

Figure 12: Cubicle with thick bedding

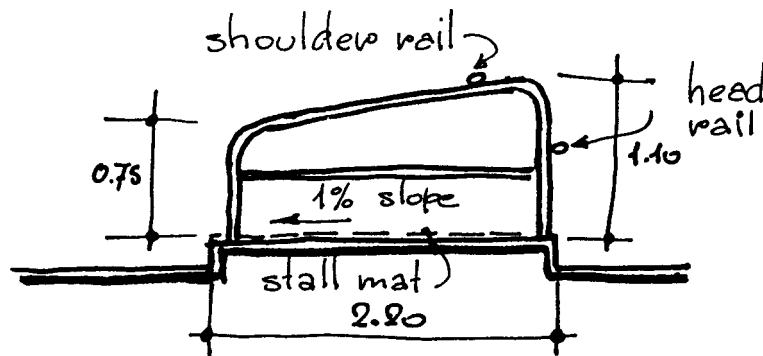

Figure 13: Cubicle with solid floor

The front of the cubicle partitions with thick bedding is 1.20 m high and the back 0.85 m. In cubicles with solid floors these measurements are 1.10 and 0.75 m respectively.

With a solid floor in the loafing alleys the height of the step into the cubicle is 0.20 m; with a slatted floor this step can be 0.15 m.

To prevent the cow from soiling the cubicle, shoulder and head rails are needed. This provision will force the cows backwards when they stand up. The distance of the adjustable shoulder rail to the back of the cubicle, measured diagonally, should be about 1.80 m, the height to the cubicle floor may vary between 1.05 and 0.90 m.

There are different types of cubicle partitions on the market; some provide a little more comfort to the cow than others, but functionally there are no real differences.

Figure 14.

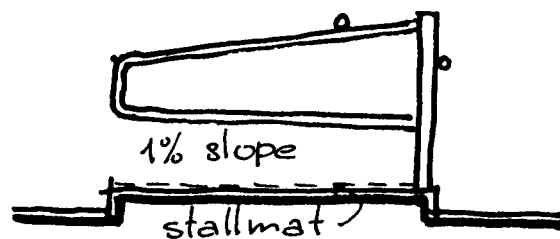

Figure 14: Cubicle partition (alternative)

The manger is separated from the loafing alley by a feeding rack. Different types of feeding racks are available. In general, the self-locking feeding rack has a manger length of 0.65 m per cow. A diagonal feeding rack with a manger length of 0.60 m is more economical.

The most simple feeding rack, the so-called English feeding rack, is made of two pipes only. However, with this type of feeding rack the cows can easily pull feed into the loafing alley and they can easily push each other aside.

Figures 15, 16 and 17.

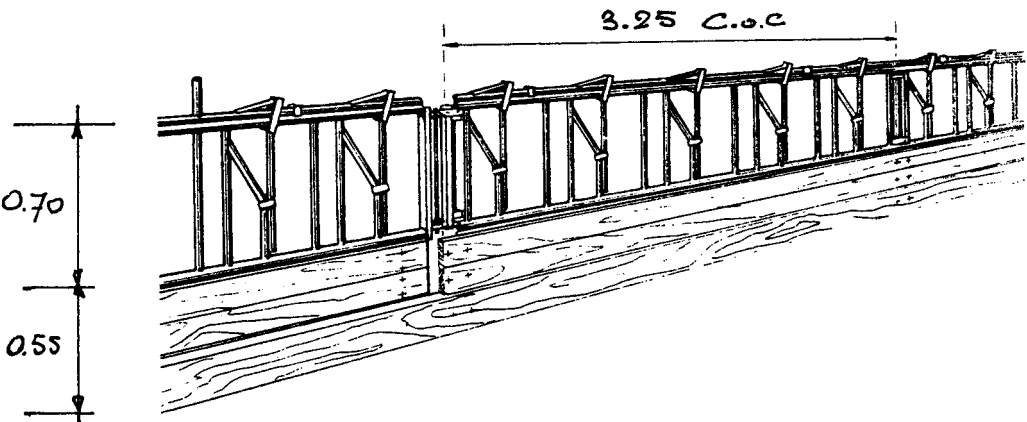

Figure 15: Self-locking feeding rack

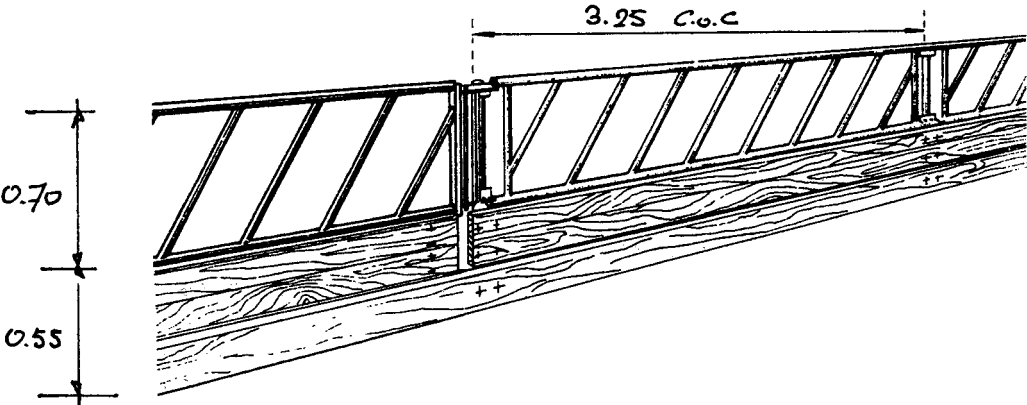

Figure 16: Diagonal feeding rack

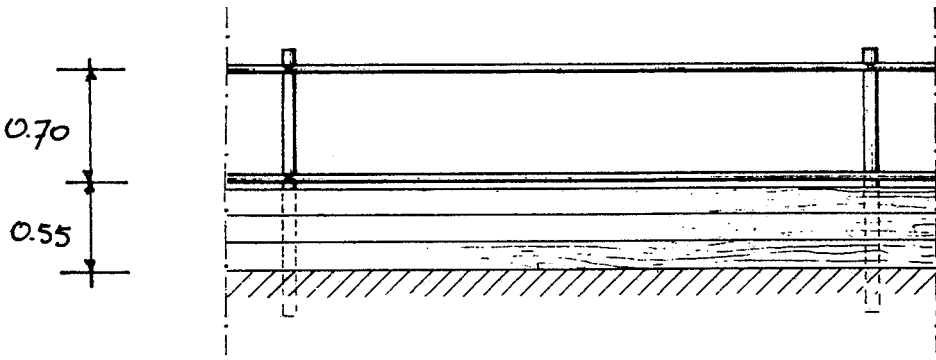

Figure 17: English type of feeding rack

7.4 Health facilities

To ensure good health care on a dairy farm, sufficient health facilities are needed.

The capacity of the health facilities and the minimum number of stalls are shown in percentages of the total number of milking and in-calf cows:

Table 7:

| Health facilities | Percentage | Minimum number |
|-------------------|------------|----------------|
| treatment area | 5 | 2 |
| separation area | 3 | 2 |
| calving area | 3 | 2 |

With tie-up housing there is no need for a special separation area.

If enough space is available behind the stalls (at least 4 m behind the manger), cows can also calve down in their own stalls.

Treatment area

This area is used for confining animals in heat, for artificial insemination, routine checks, pregnancy diagnosis and for examining sick cows.

The animals are separated when they come from the milking parlour. Therefore this area should be located close to the parlour. The width of the treatment area should be at least 0.70 m per cow and the length 3 m.

It is convenient to have a separate movable treatment box for treating hoof problems, for trimming hoofs, for taking blood samples, etc.

Separation area

To treat sick cows properly and to prevent the spread of disease agents it is sometimes necessary to separate a cow from the herd using a special separation area.

The cows can be housed in this area in 1.20 m stalls. There should also be the option to change this area into pens.

The sick cows will probably have to be milked so this area should also be near the milking parlour. Drinking water should be available. Frequent cleaning of this area is important. Therefore, a concrete floor with a gutter should be provided.

Calving area

In cubicle houses the cows should calve down in a special calving area. This permits proper attention at calving and prevents infections. Here the cows can be tied up in stalls. At least 4 m should be available behind the manger.

The above separation and calving areas should have partitions.

Stabling calving cows in the separation area and putting sick animals in the calving area should be avoided.

It is very important to clean and to disinfect the calving and separation areas after the cows have left. The manure is collected into gutters.

Foot bath

To prevent hoof problems a foot bath should be available. In loose-housing systems with a milking parlour, a foot bath measuring at least 2.00 m in length and 0.15 m in depth can be situated just by the collecting area. The width of this foot bath should be the same as that of the passage to prevent cows from passing by the bath without using it.

7.5 Housing for young stock

During the first weeks after calving, mortality can be quite high, and become a real problem, due to poor husbandry.

In the planning of a dairy farm the housing of young stock should receive special attention.

The area needed to house young stock depends on their number and on the type of housing.

The number of young stock places depends on:

- calving pattern of the dairy herd
- replacement percentages of dairy cattle
- the length of the grazing period
- division of the herd into age groups

It is advisable to divide the young stock into the following age groups:

- 0-1 month-old animals
- 1-5 months-old animals
- 5-22 months-old animals
- 22 months-old animals and older

The group up to 5 months old should be separated from the milking cows. Sometimes this group is housed in an entirely separate building on the farm.

The following table shows suitable housing systems for the different groups of young stock:

Table 8:

| Age group in months | Housing system |
|---------------------|--|
| 0-1 | individual pens with slats |
| 1-5 | tied up in stalls, group pens, cubicle houses |
| 5-22 | tied-up in stalls, loose houses with or without cubicles |

Calves from birth up to 4 weeks are best placed in clean, disinfected individual pens separated from the cows. The pen partitions should be solid and smooth with a height of 1.50 m. The floor should be equipped with wooden slats. The width between the slats should preferably be 20 mm.

The heifers can be housed with the group of non-lactating cows. The housing of these animals is similar to the housing of the lactating cows.

The following table shows the minimum measurements of cubicles and mangers of Holstein-Friesian young cattle depending on age and weight of the animals.

Table 9:

| Age in months | Weight in kg | Cubicle size in m | | Manger length in m |
|---------------|--------------|-------------------|--------|--------------------|
| | | Width | Length | |
| 1-2 | 70 | 0.60 | 1.30 | 0.35 |
| 2-5 | 150 | 0.70 | 1.50 | 0.40 |
| 5-12 | 300 | 0.80 | 1.70 | 0.50 |
| 12-18 | 410 | 0.90 | 1.90 | 0.55 |
| 18-24 | 490 | 1.00 | 2.10 | 0.60 |
| from 24 | 500 | 1.10 | 2.10 | 0.65 |

The measurements presented here may be adjusted to fit young stock of other breeds.

7.6 Environmental structures

In the tropics and subtropics **minimum facilities** for the housing of dairy cattle are quite often sufficient and appropriate.

A simple umbrella-like roof construction to prevent direct solar radiation (sunshine) is often satisfactory in many cases. Leaving out the side walls will favour natural ventilation.

The environmental provisions and general layout should also provide maximum comfort and good sanitation.

One should be aware of the ever-present moisture and corrosive waste products on a dairy farm.

Concrete, masonry and steel are the basic materials to work with in this respect. Concrete is favoured for floor slabs, alleys, waste disposal structures and foundation walls. It is not advisable, however, to use prefabricated concrete elements such as slatted floors if there is not much demand for such material locally.

Steel with sufficient corrosive protection is favoured for fences, gates, partitions and mechanical equipment.

Structural framing may be of wood or steel. Aluminium and timber products are commonly used in places free from liquid wastes and animal traffic.

The superstructure consisting of beam constructions, roofing and possibly wall constructions, should be built preferably of local materials and follow local designs.

For roofing it is desirable to use a reflecting roofing material like aluminium sheets. However, hay, straw or leaves can also provide a well shaded area when conditions are right (no strong winds, for instance).

To reduce the radiant heat load, extra insulation beneath the roofing material, preferably with an air gap, may be provided.

Structures of tie-up houses

The roof of a tie-up house is usually a beam construction covered with roofing material. Figure 18 shows an example for a single row tie-up house. With a double row house, a hatched roof construction is preferred due to the larger width.

To stimulate natural ventilation, an open ridge must be constructed. In very hot climates an extra ventilation gap halfway along the roof combined with transverse ventilation may be a good proposition.

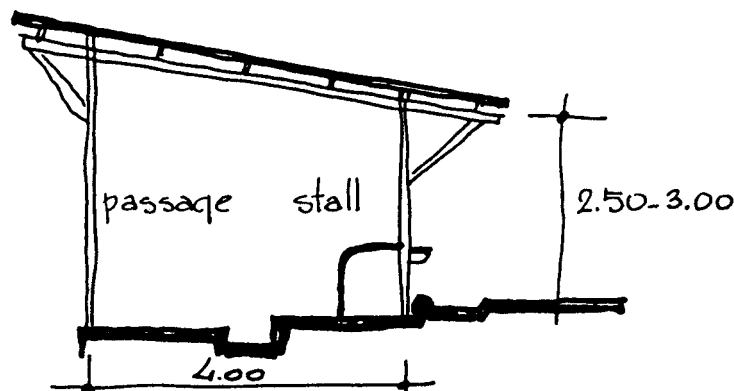

Figure 18: Single row tie-up house

With lower temperatures and/or higher wind velocities the walls should be partly closed. When enclosure increases, one should be aware of the need for sufficient ventilation.

Structures of loose houses

In loose houses the roof may be constructed in various ways. Flat roofs are satisfactory in areas with low rainfall but with higher rainfall a sloping leak-proof roof is advisable. A minimum shade structure consists of roofing only over the lying area.

For loose houses with cubicles, an East/West orientation of shading is advisable to prevent direct sunshine falling into the cubicles.

Loose houses with a common lying area should preferably run North to South so the sunlight will strike all parts of the lying area at some time each day to dry the lying area. The prevailing wind direction should also be considered when a decision is made on the siting of the buildings.

Figures 19 to 25 show examples of shade structures with various cubicle arrangements. A minimum height for the side walls of 3.00 m is recommended. Shading of the feed-loading alley behind the feed manger should be considered in order to stimulate the feed intake of the cows.

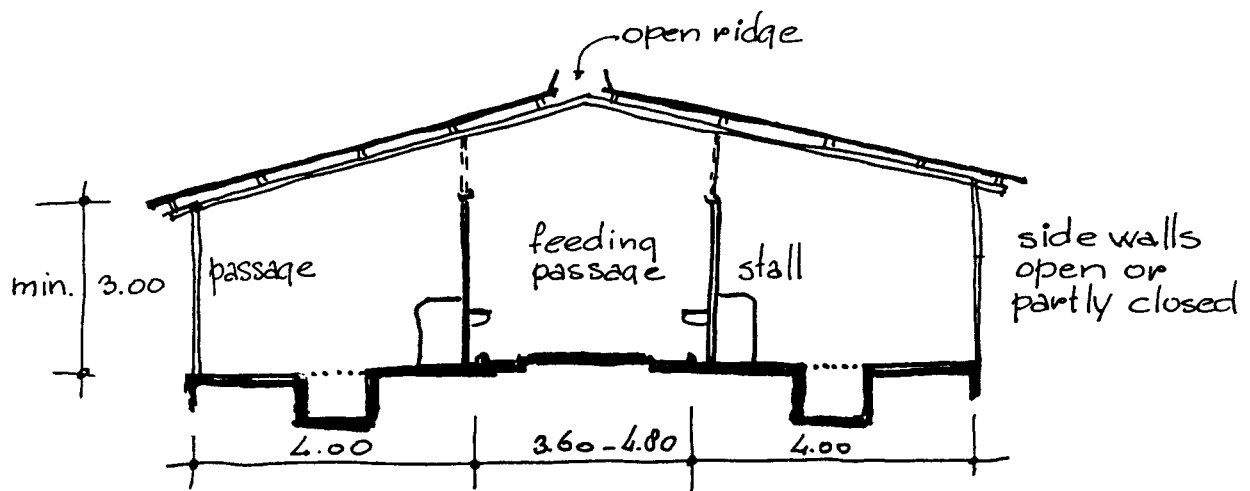

Figure 19: Two row tie-up house with open ridge

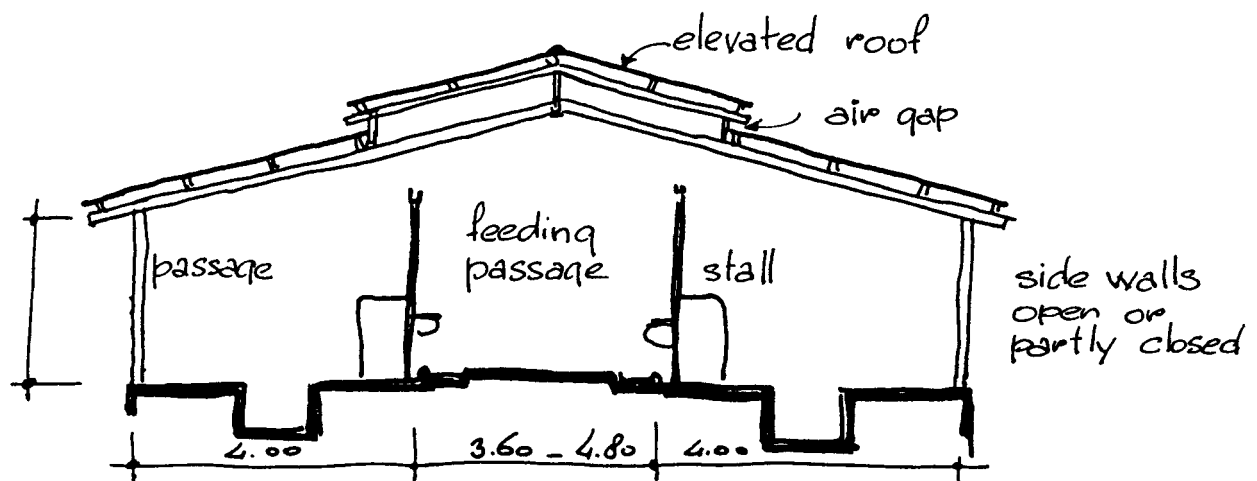

Figure 20: Two row tie-up house with elevated roof

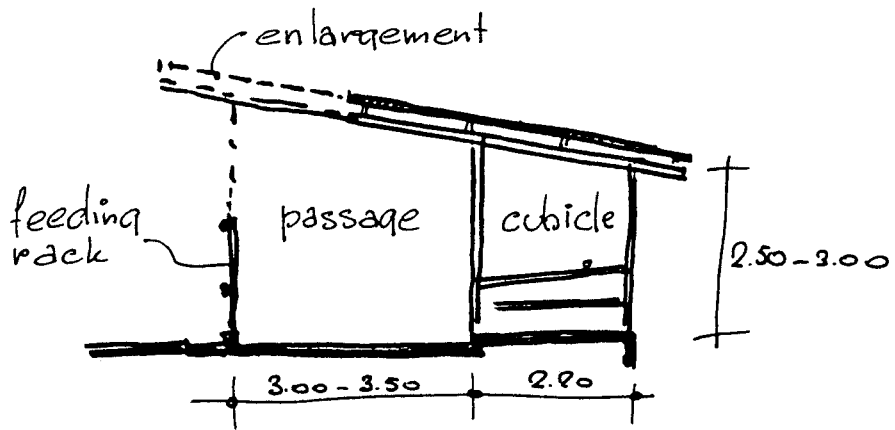

Figure 21: Single row cubicle house

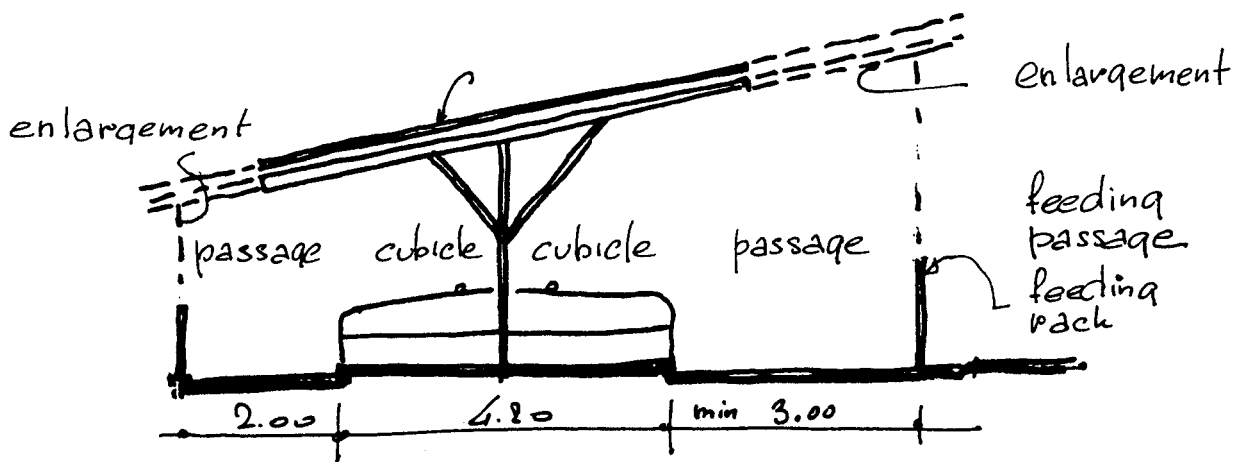

Figure 22: Double row cubicle house – head to head

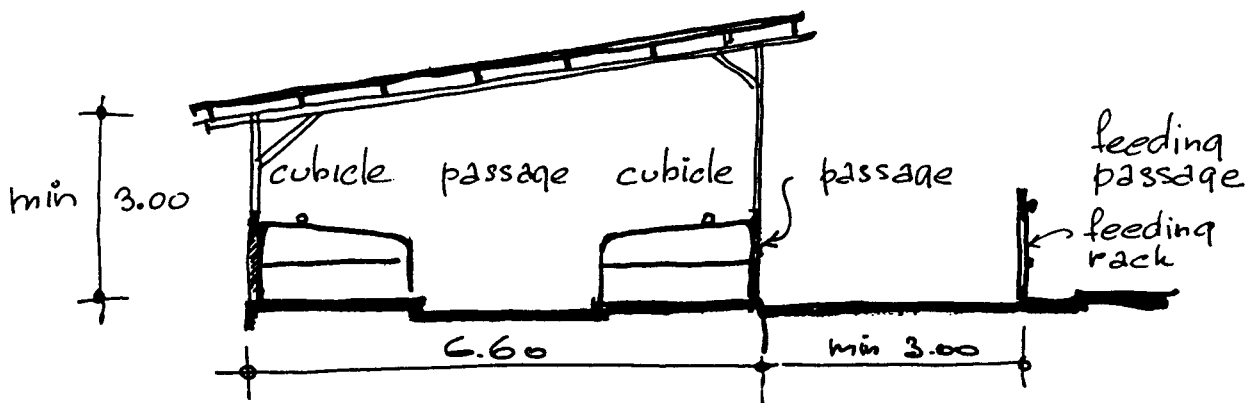

Figure 23: Double row cubicle house – tail to tail

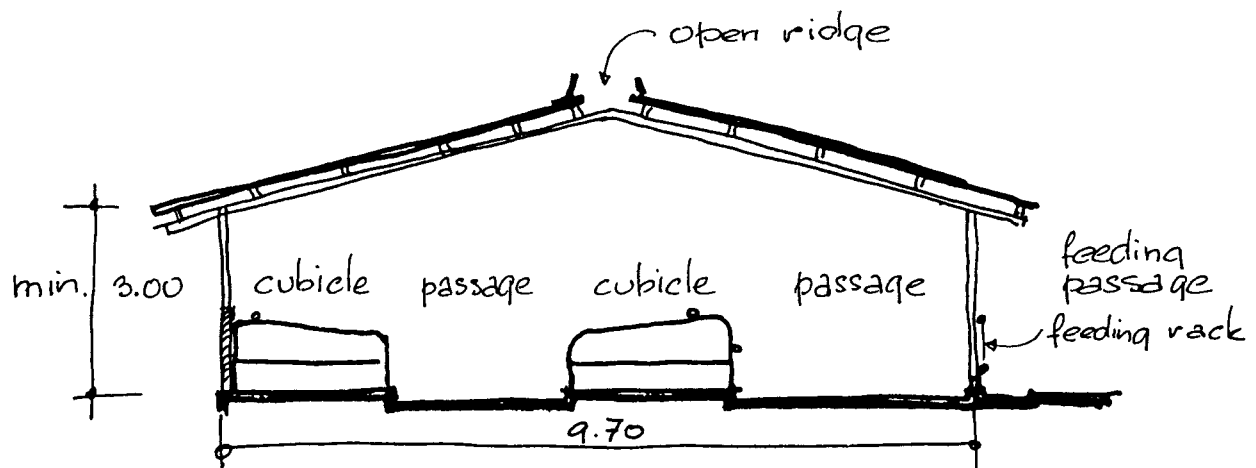

Figure 24: Double row cubicle house with pitched roof

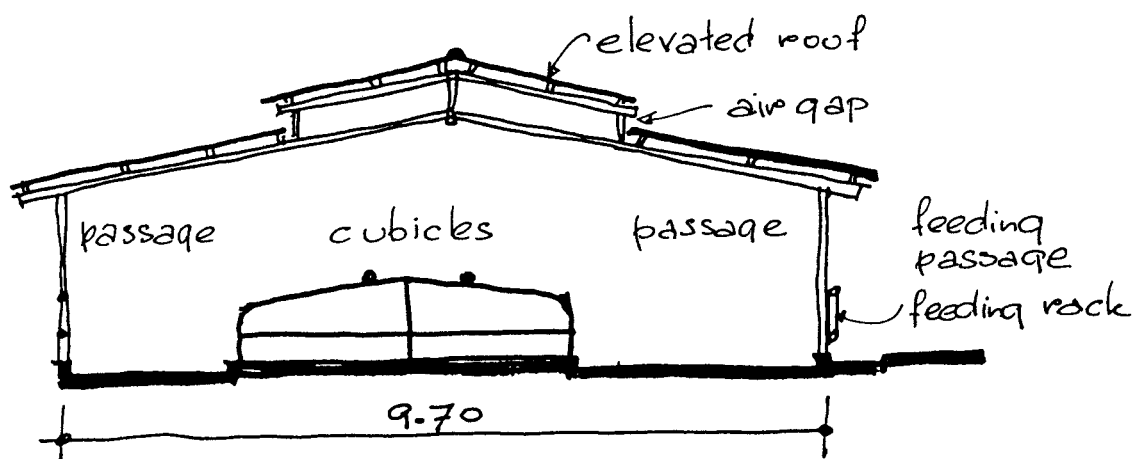

Figure 25: Double row cubicle house with elevated roof

A disadvantage of shading the loafing area may be that the cows lie down in this alley and become dirty. If the cows mainly feed at night-time, it is advisable not to shade the feeding-loafing alley.

To prevent rain from falling into the feeding manger it is desirable to cover the manger and the feeding passage partly or entirely.

Depending on temperature, wind velocity and rainfall, side walls have to be left out partly or entirely.

The concrete alleys of loose houses should slope in the direction of manure movement. A 3% slope is recommended if the manure is scraped out. The floor of the alley should be level from side to side.

New concrete floors are highly abrasive for the hoofs of the cows and will cause sore feet until traffic has smoothed the surface. The break-in period can be shortened by dragging a heavy concrete block or metal scraper over the new floor.

In Figure 26 a basic plan for a dairy house with cubicles in tropical areas is shown. The head-to-head arrangement provides optimal shade with a minimum shade structure. It is preferred to locate the drinking bowls under the shades with water provided through the ground.

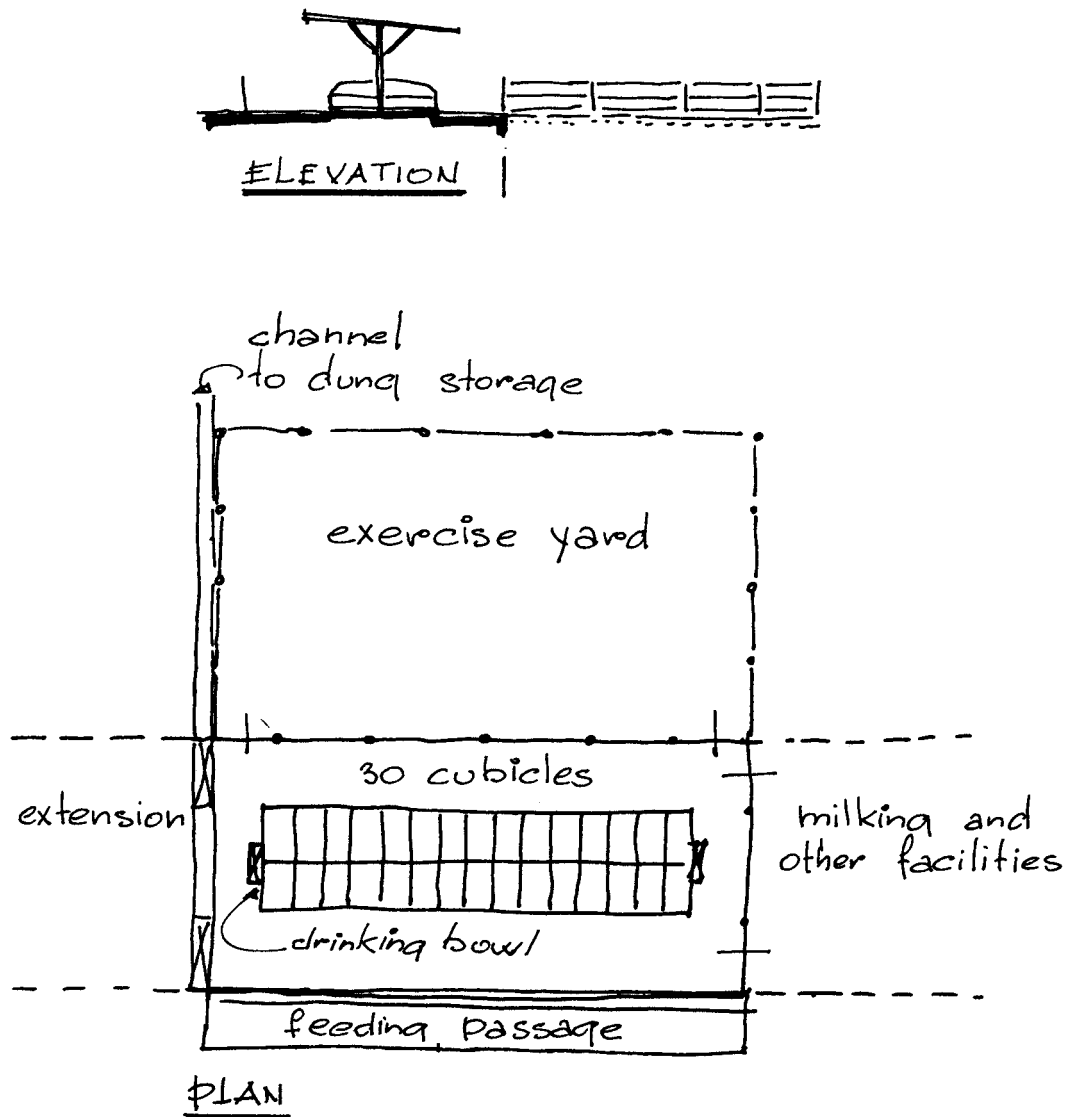

Figure 26: Basic plan of loose house with cubicles

It is advisable to provide unpaved areas next to concrete areas in order to permit more exercise. These unpaved areas have to be cleared of irregularities which may cause hoof problems. During wet periods these areas should be closed off.

The manure is collected into a central dung channel, to be discharged into a silo or other kind of storage.

Milking and other facilities may be located in an extended part of the cow house. It is also possible to situate these facilities together with the calves and the young stock in a separate building.

Additional notes:

Due to pressure (less land available; more and more people) smallholder dairy farmers in warm climate zones are forced more and more towards a form of **zero grazing**. The vicinity of large towns and good milk prices stimulate zero grazing.

Stall feeding normally leads to less feed and water offered, with less variability in the feed, leading to a lower feed intake. The farmer has to be aware of this.

The cows should be 'exercised' regularly: for sunlight; exercise is good for hoof problems and calving.

Positive aspects of zero grazing are protection from direct harmful effects: too much heat, mud, wind, ticks and tse-tse flies, worms and flukes. But if stall fed cows are left out to graze, acute diseases may occur.

On the other hand, most smallholder stables experience an increased incidence of diseases (affecting lungs, intestines, udder, claws and reproduction), through closer animal contact, poor ventilation, dust, muddiness, lack of proper bedding and cleanliness, and general poor hygiene around milking and calving. Mastitis and uterine infections are common.

Other positive aspects of housing are: keeping out predators, thieves, reduced burden of day to day herding, production of farmyard manure. But housing also means a lot of work; think of feeding!

Types of housing: under trees, in poled shade building, stanchion type barns with facilities of a gutter to collect manure, shed with cubicles for resting and an area for walking and feeding.

8 Suggested practicals in dairy farming training

In vocational agricultural training **practical lessons** ('practicals') can be of great help to prepare the student for his or her future agricultural occupation. If the student is to become a farmer, farm manager or extension worker, he/she should be able to do all that is necessary for animals and crops to thrive and be profitable, make judgements, take decisions and act on these decisions. Theory lessons do not prepare the student sufficiently, but good practicals can be of great help.

AGROMISA has a brochure on this subject called 'Guide to Effective Teaching' in which the role of practicals in agricultural training is described. The way to conduct practicals also receives due attention in this guide. Interested readers are referred to this brochure. It can be obtained by contacting AGROMISA.

In dairy farming training, the **setting up of valid practicals** should be a main concern of course designers and teaching staff. Otherwise teachers and students all too often tend to spend too much time in classrooms.

'Routine work with animals' is very important in dairy farming training, but it should not be exaggerated.

If it is felt that students should be able to do a certain job 'routinely' (without giving it much thought) and at a certain speed (proficiency), **repetition** is required. But training in a particular job should stop when the students are capable of performing it satisfactorily (they have passed a test). They should then go on to learning something else. Students are '**too expensive to keep**' to be used as labourers, which happens sometimes.

On the following pages an attempt has been made to list (and to describe briefly) topics for practical lessons which are possible and recommended in a dairy farming training centre with a dairy herd. The setting is Central Africa. There are grazing pastures and there is some arable land for fodder production. There is no irrigation. The Centre also has a ranch with beef cattle. There are classrooms and a modest school laboratory room.

The practicals are mainly about the dairy herd and its immediate requirements. No attention is paid to subjects such as farm management, crop production and farm mechanics, although they are, perhaps, equally important.

The practicals are listed in arbitrary order.

Naturally, under certain circumstances, some of these practicals may not be needed; or perhaps additional practicals may be required.

8.1 List of topics for practicals in dairy farming training within regular teaching hours

1 Establishment, maintenance and cropping of planted pastures

Early in the course the trainees plant and grow different grasses in small, fenced(?) plots on a suitable tract of land (no water logging), preferably not too far away from the premises.

The size of the plots should be such that in principle the trainees can do all the work that is involved. The trainees follow the development of the grasses; they maintain the plots and do the 'harvesting' (cutting, grazing) for the duration of the entire course. Also the collection, storage and harvesting of seed and planting material.

Some 'experimentation' could be introduced, for instance, different fertilizer levels, use of herbicides, intercropping, mixing grasses with legumes.

Let the trainees do suitable 'counts' as much as possible; for instance, square metre plant stand counts, crop weights, output per person (labour).

These plots are not individual trainee plots; all trainees should work on all plots and should profit mentally from all plots.

This is an attractive series of practicals that could be quite beneficial. However, careful planning is required: which grasses, size of the plots, where, which treatments, which counts.

To be repeated every year.

2 Establishment and maintenance of legume crops

This should be conducted on similar lines.

Legumes are more difficult to establish than grasses.

Consider broadcasting or sowing in rows, and the role of fertilizers.

One could think of the following non-irrigated legume crops:

- rainy season legumes (eleusine, siratro, desmodium green and silver leaf)
- dry season legume (stylo)
- legume shrub (leucaena)

3 Making silage

Making silage is a subject which requires extensive treatment if it is a recommended practice in the region. First of all, the trainees should be involved in the normal, yearly silage making operation that is usually carried out at the Centre.

However, this operation should not be 'disturbed' by the trainees, because it has to be done hurriedly, within a limited time period.

Mixing the trainees with the regular labour force would be a possibility but the training value would be rather limited.

A suggestion is to involve the trainees from a farm management point of view in the normal silage making operation. The subject of making silage could be discussed extensively in the classroom, just prior to the actual silage making operation. The teacher could invent and assign 'counting' tasks for practicals taking place while the operation is under way.

The results should be analyzed and discussed later on, in the classroom.

Secondly, the trainees could possibly make one or two minimum-size silage heaps, all by themselves using a crop from the farm (not planted by the trainees). Perhaps one hectare of maize would do? Or grass?

The trainees prepare the pits. The trainees cut the crop and chop it up, all by hand. They load and haul the crop (ox cart?), establish and cover the heaps.

A working plan is made in the classroom beforehand.

In this case it may be necessary to work outside regular teaching hours.

Perhaps some 'experimentation' could be introduced, possibly resulting in good, average and poor silage.

Later during the course the quality of the product is evaluated. Even if the quality of the product turns out to be poor, this should not be regretted too much; it is the training value which counts in this case (contrary to the regular silage making operation). Next time the results will perhaps be better.

Conclusion: should be tried seriously, could be most interesting for trainers and trainees.

4 Tree killing

Select a manageable piece of land on which the trainees can practise the killing of trees if this is a common practice in the region.

Introduce ring-barking and the application of arboricides.

The trainees should return regularly and evaluate the results.

Introduce some 'experimentation'. Let the trainees mark the trees and make some kind of inventory of the trees before the work starts.

This work could be made useful for the centre itself (bush clearing), but the training aspects should predominate.

5 Field recognition of browsable trees

Introduce names, characteristics, value, how to recognize.

6 Hay making

Hay making should be carried out on the plots described under heading number 1 or on regular pasture land of the Centre.

Rhodes grass is quite suitable for hay making.

Try to introduce some 'experimentation'

Use of tripods? baling (large, small); loose stacking.

7 Mixing of concentrates

After the trainees have had the necessary 'theory' in plenary classroom lessons, they should practise the preparation of concentrates, in or around the cowshed. This is an important practical.

The trainees work in pairs; each pair is asked to prepare mixtures, along the lines described elsewhere in this series on modern dairy farming (volume 1). Preferably with the real ingredients but, if necessary, with dummy ingredients.

Computation forms an important part of the practical (but the feeding value and units used have already been discussed in the classroom; when the trainees do the practical, they should be fully familiar with those aspects).

Possible mixtures:

- a grain with another grain
- a grain with a protein-rich ingredient
- urea with molasses (be aware of lumps!)
- dry and pulverized poultry manure with a grain

8 Assisting at calving; trainees later to be responsible for a few calvings

Practicals with live cows are sometimes difficult to organize because they do not observe regular teaching hours.

This is the case with calving. On the other hand, the trainees should become familiar with the calving process (proficiency cannot be obtained at the Centre).

Suggestions

Once in a while a practical could be spent on attending a calving (in the hope that it will actually take place during that practical). This may have to take place at short notice.

This should take place in the presence of the person who is responsible and in the presence of the teacher/instructor who gives explanations. Try to actively involve at least some of the trainees in the calving process.

See our guide 'Reproduction in dairy cattle' (2 parts).

Later on, outside regular teaching hours (or even at night), a pair of trainees could be made responsible for a calving, ensuring the person normally responsible is within calling distance.

Naturally the trainees take their turns.

By the end of the course, each trainee should have had a few turns as a minimum. Ten calvings (followed by calf care immediately after birth) would be very good.

9 De-budding of calves

Difficult to organize as a practical.

Removal of extra teats could be coped with at the same time as de-budding.
Several methods to be demonstrated? Advantages and disadvantages. Which method is the most suitable (and recommended) locally?

10 The use of the cow calendar

See elsewhere in this guide and our 'Reproduction in dairy cattle' guide.

Although the cow calendar is not used everywhere, it has excellent training value.

Construct an imitation cow calendar (when the real one is in use). Explain how it works and how it should be used. Discuss the cow calendar that is actually in use at the Centre.

After the trainees have understood the calendar, the teacher/instructor 'plays' with the imitation cow calendar, asking questions to which the trainees give written replies. This can be in the form of a test to serve as an evaluation of each trainee.

N.B.: There are several other practicals in this list which can serve for objective individual evaluation of trainees.

11 Ox-training (where appropriate)

The purpose of the programme is:

- 1 to make the trainees aware of the possibilities in the use of ox-drawn farming equipment
- 2 training of oxen (including cows)
- 3 trainees: how to train oxen (including cows) and how to use ox-drawn farming equipment

This could be done within regular teaching hours.

The trainees would have to start with fresh oxen (and cows?). This means that the Centre would have to raise such animals every year; how many?

Four animals per group of 8 trainees working in pairs, would be needed for each practical. One teacher/instructor would have to supervise the proceedings.

Apart from this 'regular' programme, oxen and cows should be available to the trainees, for instance, for haulage work in afternoon hours.

12 Cattle assessment (judgment)

The trainees (working in pairs) assess (judge) dairy cattle, after having learned the criteria to be applied. They should fill in the forms which have been established for this purpose. It is suggested that they look for good conformation only, **not** for breed characteristics.

At the end, results are compared and discussed. An interesting practical from a training point of view. The assessment of ranch animals should also receive due attention (beef cattle). Bulls and oxen should also be included.

This practical could be preceded by a practical on the identification of the various 'components' of a cow, on live animals. Prepare tests in order to check the results because here again, the trainees should be active, not the teacher/instructor.

13 Age estimation of cattle

After the trainees have learned how to estimate the age of cattle, prepare tests. Include systems of ear notching/branding for knowing the age of cattle.

14 Hoof care (where appropriate)

See our guide 'Foot care in cattle'.

15 Cattle identification

Demonstration on branding, eartags, sketches and notching.

Difficult to 'practise', with the exception of making sketches (let the trainees actually do this).

16 Ranch work

At regular intervals, various operations have to be carried out on the ranch (beef cattle). Actively involve the trainees in these operations, let them do the work that is normally done by the regular labour force, until they are really familiar with this work.

This is an attractive practical from a training point of view and one which is regularly repeated. It needs close supervision, however. Although problems may occur, the herd should be there for basic training purposes in first instance. This is to ensure the trainees become confident with cattle. All routine vaccinations and drug administration should be done by the trainees. The ranch provides excellent opportunities in this respect.

17 Dummy hand milking

Practice on a set of artificial udders.

Include the use of detergents and disinfectants.

Set standards that must be reached by the trainees. Trainees who have 'passed' need not continue with the practical.

Introduce an element of competition; do everything to make this dummy hand milking as attractive as possible to the trainees (without this, it easily becomes very tedious and boring).

N.B.: real hand milking is naturally a very important training activity, but it does not fit in with the regular teaching hours dealt with here.

18 Construction, operation, cleaning and maintenance of the milking machine

See volume 2 of this guide, which is about hand milking, machine milking and the storage of milk on the farm, including milk quality aspects.

19 Calf weight taking and recording; computation of growth rates

An attractive practical, in which all trainees of a section can be actively involved. It involves the use of scales and tape measures.

During a practical, pairs of trainees weigh as many calves as possible and record their weight by their identification mark. The trainees return at certain intervals and repeat weighing and recording.

This can be used for the computation of growth rates. Discussion.

20 Weight estimation of adult cattle

Assign definite tasks to individual trainees or pairs of trainees, after having explained what should be done.

Discuss the use of human eyesight and the use of the weight band for cattle. Note down the estimated weights. At the end, the results are compared and discussed.

Give a demonstration on the use of scales.

21 Cattle vaccination

Vaccination could be practised with a dummy vaccination liquid (sterile biological salt solution). Practise on as many cows as possible, in order to reduce skin damage.

Another possibility is to let the trainees carry out all routine vaccinations, in the dairy herd as well as on the ranch.

Methods of vaccination to be learned:

- intramuscular (easy)
- subcutaneous

Consult a vet about this practical. Make sure that the trainer concerned knows how to vaccinate properly (let this be checked by the veterinarian).

22 Drug administering

Let all routine drug administering be carried out by the trainees. Drenching (bottle, gun), the use of the hose pipe (tympany) and the treatment of mastitis should be covered.

Drug administering used in calving.

23 The preparation of solutions and dilutions

An indoor practical, in the school laboratory room.

Highlight the difference between volume % and mass %. Let the trainees work with sugar (a solid to start with) and then with a liquid (KMnO₄, for instance).

This lesson could be followed by a practical about **labels** which one can come across in agriculture and dairy farming. The teacher/instructor could make a collection of various labels (drugs, herbicides, insecticides). What is written on these labels and what does it mean?

Actively involve the trainees (this should not be so difficult). Ask questions continuously.

Finally, some commonly used preparations could be made, for instance, a mixture of vinegar & cooking oil against tympany.

24 Cattle dipping and spraying (tick control)

This is a very important series of practicals in 'tick country'. Trainees 'should know this backwards'; they should become really proficient in this matter.

One could think of the following training elements:

- where to look for ticks on cattle; combined with spraying effectiveness check (every day count the number of ticks found until the next spraying date)
- hand spraying (very important); emphasis on correct solution and on the fact that **all** parts of the animal must be reached (under the tail, in the ears!)
- maintenance of the sprayer
- making up dip solutions (using 'home-made' measure)
- dipping (calibration, head count system, precautions)
- spray race is less important

The ranch and the dairy herd offer good opportunities for practice.

25 How to check the health of cattle

Concentrate on (a) behaviour, (b) feed intake and (c) milk yield, plus temperature reading.

Temperature reading is probably the most concrete aspect; it should be preceded by temperature reading in the laboratory (beakers with water at different temperatures).

Thermometers: to be handled with care!

26 Crush construction

The trainees work in pairs and erect the following crushes, with materials which are on hand.

At the end, the structures are dismantled (for a succeeding section of trainees):

- simple crush race for hand spraying
- V-crush for tethering a single animal
- a four-post crush for tethering a single animal

27 How to restrain cattle

How to let a cow down as this should be done (with a rope).

Hoisting of a foot (for hoof care purposes).

28 Cow grooming

The trainees should groom a few cows individually.

It once again gives them the 'feel' of cows (hopefully a pleasant experience for the cow this time) and it may be useful in view of agricultural shows.

29 Milk tests

It may be considered useful to let the trainees carry out a few simple milk tests, in the laboratory room of the school.

For instance, the mastitis test done on modern dairy farms.

30 Castration of calves

Discuss the Burdizzo method.

The ranch offers good opportunities for practice.

31 Construction of various types of fences

An important practical.

If possible, to be integrated with normal fencing operations.

Training elements:

- digging a hole and putting up one post securely
- erection of a fence straining box
- erection of 50 metres fence in a straight line
- straining of a fence

Work with barbed wire, plain wire, wooden droppers and metal droppers.

32 Making a complete ration for dairy cows

What is a complete ration – how to estimate quantities in the feeding of the dairy herd of the school? Begin by letting the trainees try this.

33 Checking of dry matter intake by dairy cows

Feed silage to a certain number of dairy cows, ad lib and for one full day. Estimate the quantity of silage that is available for the cows.

The next day, estimate the quantity that is left. Assess the dry matter content of this silage.

How much dry matter has been taken in per cow (average)?

Compare this with what is usually stated in books.

34 Yield estimation of a fodder crop in the field

Conduct sample taking (about five square metres each time), computations, and make an estimation of dry matter production (kg DM per hectare).

35 Determination of dry matter content in roughage

Make a rough estimation by twisting a handful between the hands. Also conduct a simple laboratory test if possible.

36 Judging the quality of roughage

Consider the origin and the growing stage when harvested. Assess the colour, smell, palatability. Make an estimation of DM content, energy value and crude protein content. Compare the overall quality of the product with the average product.

37 The preparation of artificial milk from a powder

8.2 Suggestions for learning activities outside regular teaching hours

Certain activities have already been mentioned and are not repeated here (for instance, calving).

1 Hand milking (and machine milking where appropriate)

Hand milking is presumably a 'must' in many places. The trainees should really acquire proficiency in this particular skill. Their performance should be regularly measured (individual tests). A class can work section-wise.

Is one year of milking enough (apart from some 'maintenance' during the second year)?

See our volume 2, which is about milk and milking.

2 Heat detection

For a 2-3 week period an individual trainee (or a pair) should try to detect and record all heats in the dairy herd of the school. Access to relevant records should not be available.

At first be guided by the person who is responsible for heat detection (and who remains responsible!). Later it should be conducted with no communication with this person.

3 Dairy herd recording

This is also a very important learning activity.

Perhaps the following would work and be satisfactory.

The teacher gives instructions in the classroom. Discuss what is to be recorded and how. The idea is to establish a kind of parallel herd record system, for use in the classroom.

The teacher makes a pair of trainees responsible, possibly for a period of about three weeks. After this, another pair takes over. An important point is that the trainees should not simply copy what is recorded in the dairy herd record (although this cannot be entirely avoided).

With the aid of the parallel herd record, various matters could be discussed in the classroom. Which decisions does 'the farm' take and which decisions ought perhaps to have been taken?

Compute the average calving interval, conception rate and possibly other herd data; discussion.

A lot depends on the teacher; facilities are hardly needed

This is a good example of integrating classroom teaching & 'reality'.

4 Disease detection

For a certain period a pair of trainees could be asked to check the dairy herd daily and to report diseases. They should also note down what is done about the diseases.

Trainees should take turns.

5 Responsibility for calf rearing

For a certain period a pair of trainees does all the work involved with calf rearing.

6 Well prepared visits to dairy farms in the neighbourhood

Make individual students responsible for taking notes. To be followed by discussion.