

[search](#)[subjects](#)[titles a-z](#)[organization](#)[how to](#)

## Biomass Gasification - Technology and Utilisation

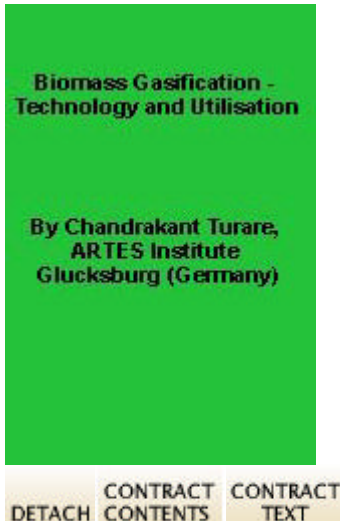

*(introductory text)*

Overview of Gasification Technology

Biomass as Gasification Fuel

Gasification for Energy Supply

Gasification History and Development

Gasification Process

Producer Gas and it's Constituents

Hazards with Producer Gas



### Gas Producers (Gasifiers)

*(introductory text)*

Updraft gas producer

Downdraft gas producer

Twin-fire gas producer

Crossdraft gas producer

Other gas producers



### Impact of Fuel Properties on Gasification

*(introductory text)*

Energy content of fuel

Fuel moisture content

Particle size and distribution

Bulk density of fuel

Fuel form

Volatile matter content of fuel

Fuels and their ash content

Reactivity of fuel



### Suitability of Some Biomass Fuels

*(introductory text)*

Charcoal

Wood

Sawdust

Peat

Agricultural residues



### Producer Gas Drive Engines

*(introductory text)*

Performance of gasifier-engine system

Operational difference between diesel and gasoline engine

Conversion of gasoline engine to producer gas

- 📄 Conversion of diesel engine to producer gas
- 📄 Conditioning of Producer Gas
- 📄 Troubles with Gasification System
- 📄 Literatures on Gasification

## Biomass Gasification - Technology and Utilisation

By Chandrakant Turare, ARTES Institute, Glucksburg (Germany)

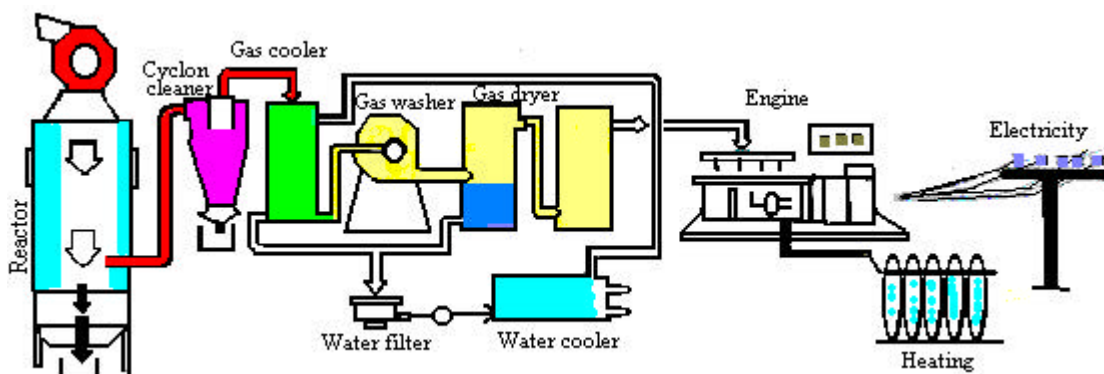

Image

Biomass gasification, a century old technology, is viewed today as an alternative to conventional fuel. In gasification process, wood, charcoal and other biomass materials are gasified to generate so called 'producer gas' for power or electricity generation. Gasification system basically consists of a gasifier unit, purification system and energy converters - burner or engine. This internet documentation gives total insight into gasification technology.

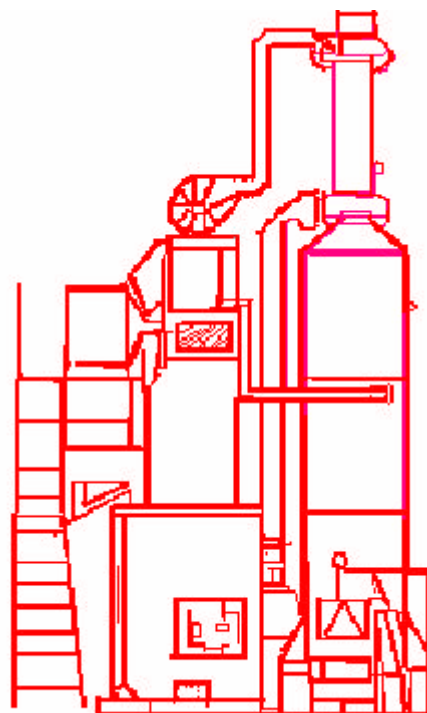

Image

## Overview of Gasification Technology

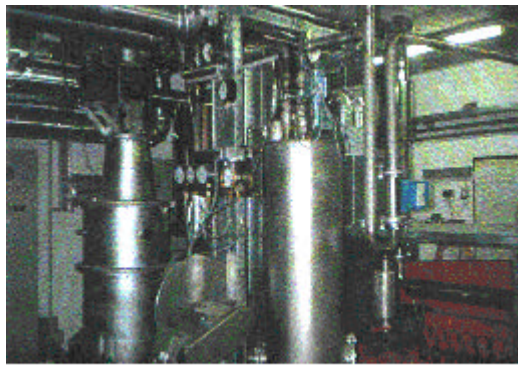

**Wood gasifier for co-gen set**

### Image

Gasification is a century old technology, which flourished quite well before and during the second world war. The technology disappeared soon after the second world war, when liquid fuel became easily available. The interests in the gasification technology has undergone many ups and downs in running century. Today, because of increased fuel prices and environmental concern, there is renewed interest in this century old technology. Gasification has become more modern and quite sophisticated technology.

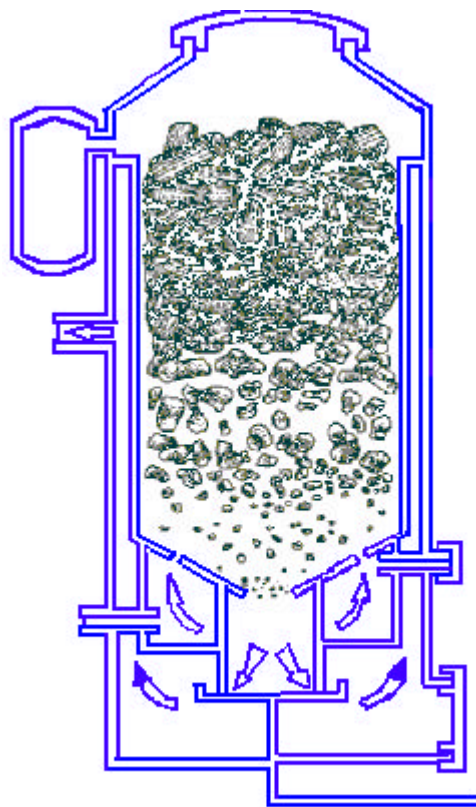

### Image

The advantage of this technology is decentralized energy conversion system which operates economically even for small scale .A gas producer is a simple device consisting of usually cylindrical container with space for fuel, air inlet, gas exit and grate. It can be made of fire bricks, steel or concrete and oil barrels. The design of gasifier depends upon type of fuel used and whether gasifier is portable or stationary. Gasifier alone itself is of little use. The complete gasification system consists of gasification unit (gasifier), purification unit and energy converter - burners or internal combustion

engine.

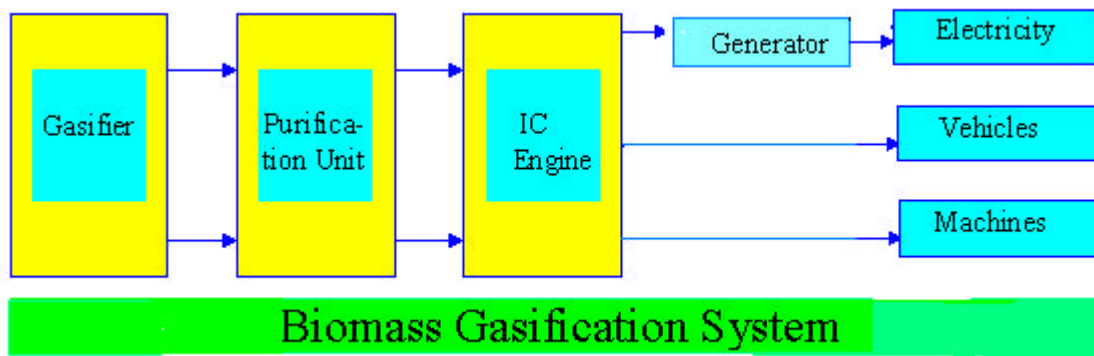

Image

Gasification is basically a thermochemical process which converts biomass materials into gaseous component. The results of gasification is the producer gas, containing carbon monoxide, hydrogen, methane and some other inert gases. Mixed with air, the producer gas can be used in gasoline or diesel engine with little modifications.

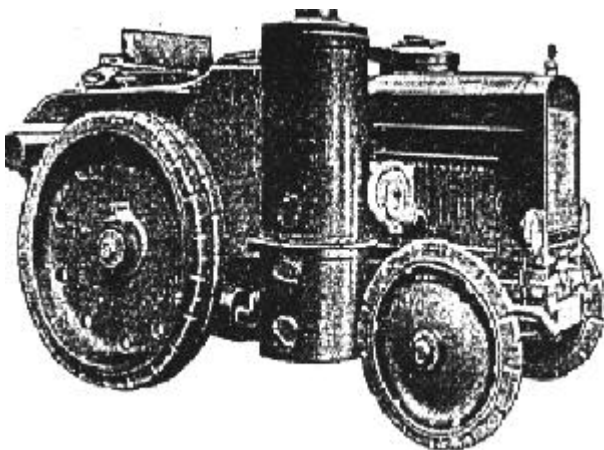

Based on the design of gasifiers and type of fuels used, there exists different kinds of gasifiers. Portable gasifiers are mostly used for running vehicles. Stationary gasifiers combined with engines are widely used in rural areas of developing countries for many purpose including generation of electricity and running irrigation pumps. Technologies such biomass gasification which allow utilization of biomass fuel are of great importance.

Image

Theoretically, almost all kinds of biomass with moisture content of 5-30% can be gasified, however, not every biomass fuel can lead to the successful gasification. Most of the development work is carried out with common fuels such as coal, charcoal and wood. It was recognized that fuel properties such as surface, size, shape as well as moisture content, volatile matter and carbon content influence gasification.



Image

The key to a successful design of gasifier is to understand the properties and thermal behaviour of the fuel as fed to the gasifier. Operation of gasification system demands knowledgeable and skilled operator. Those interested in this technology must remember that it requires hard work and tolerance. Compared to conventional system such as liquid fuel run engines, biomass gasification technology is inconvenient. But it is economical at many places and may lead to self-reliance in the crucial time of fuel crisis.

**Biomass as Gasification Fuel**

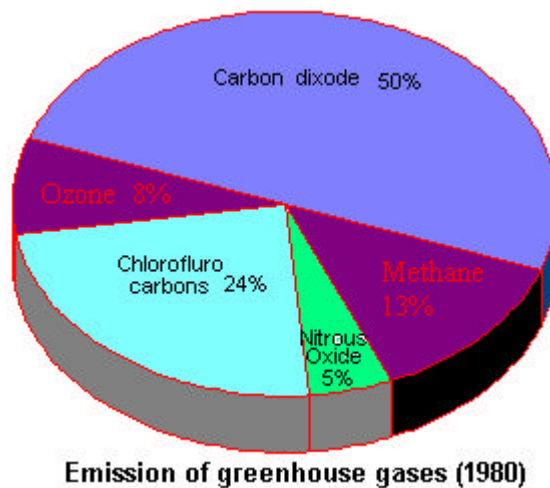

Image

Great environmental concern is expressed over the release of CO<sub>2</sub> from the burning of fossil fuels. When fossil fuels are burnt, carbon from fuels react with oxygen from air and produce CO<sub>2</sub>. This is the reason for steady increasing CO<sub>2</sub> content of atmosphere. Carbon dioxide contributes to 50% of green house effect.





Image

One of the remedies to limit the rising content of CO<sub>2</sub> in the atmosphere is energetic use of biomass fuel. Biomass is basically an organic material, which includes wood, crop residues, solid waste, animal wastes, sewage, and waste from food processing. Biomass is made up of mainly carbon and hydrogen.

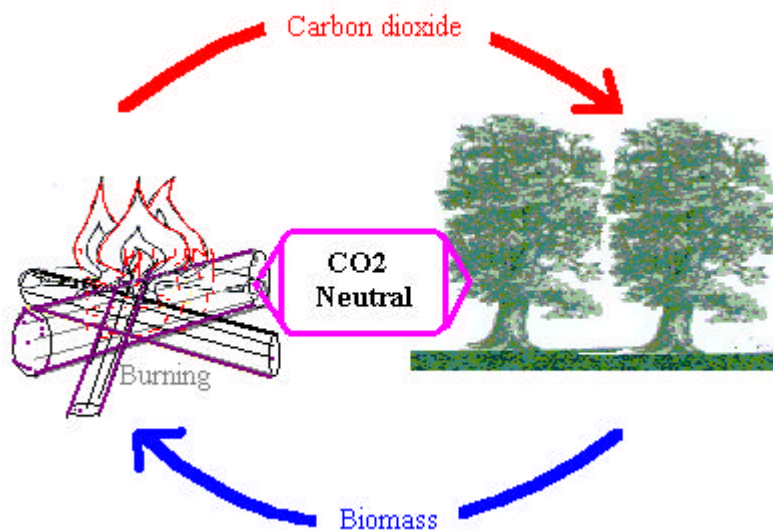

Image

When biomass is burnt, CO<sub>2</sub> is released in the atmosphere. Released CO<sub>2</sub> is absorbed by growing plants during the photosynthesis, keeping CO<sub>2</sub> content in the atmosphere same. Biomass gasification is one of the technologies of energetic use of biomass.

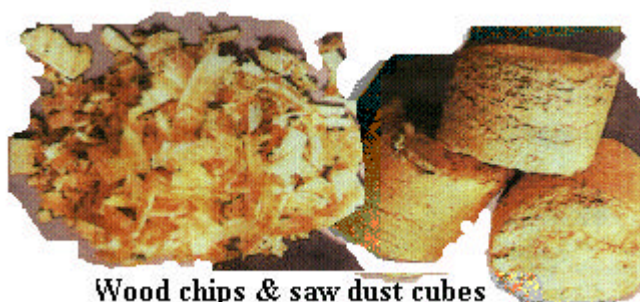

Wood chips & saw dust cubes

## Image

Theoretically, any biomass material with moisture content of 5-30% can be gasified as the basic composition of carbon, hydrogen and oxygen is same. This means that agricultural wastes such as cotton stalks, saw dust, nutshells, coconut husks, rice husks and forestry residues - bark, branches and trunk can be used for gasification.

## Gasification for Energy Supply

Rural areas in the developing countries are characterized by disperse population and a lack of infrastructure . Energy is the basic mean in improving the living standard and productivity. Energy is required in household for lighting and running electrical apparatus such as TV and Radio. Energy is also demanded in agriculture for operating irrigation pumps and other machinery such as thresher.

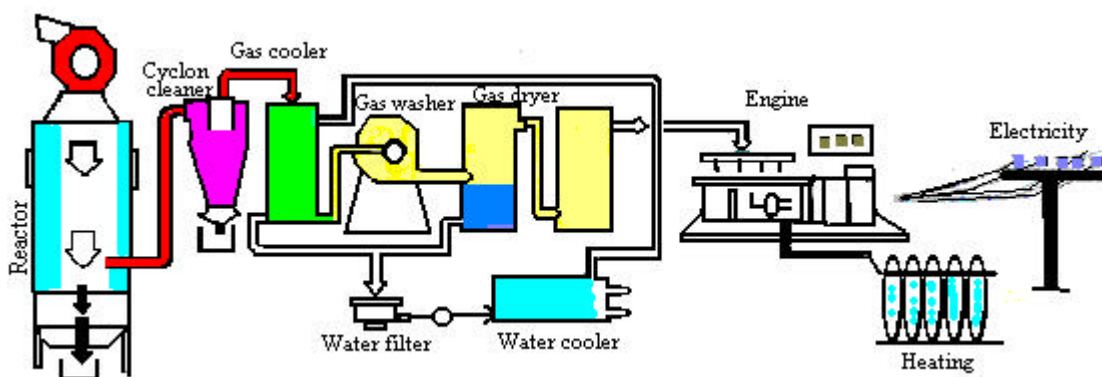

## Image

Gasifier-engine system combined with generator provides electrical energy for lighting, and other household purposes. Small scale gasifier system (10-30 kw) would be appropriate for multitudes of village applications in developing countries.

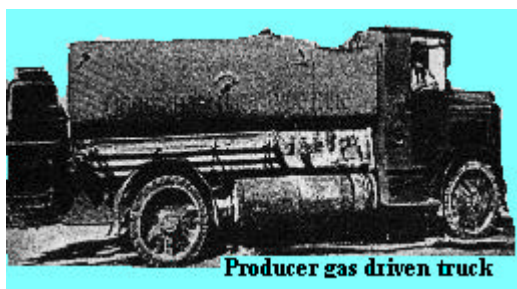

## Image

Gasifiers, when integrated with engines, provide mechanical power which can be used for running automobiles and many other stationary machinery. The use of downdraft gasifiers fueled with wood or charcoal to power cars, lorries, buses, trains, boats and ships has already proved it's worth in the past. Before and during second world war, gasifiers were largely used to power vehicles. Most of the gasoline and diesel driven vehicles during this period were converted to producer gas drive.

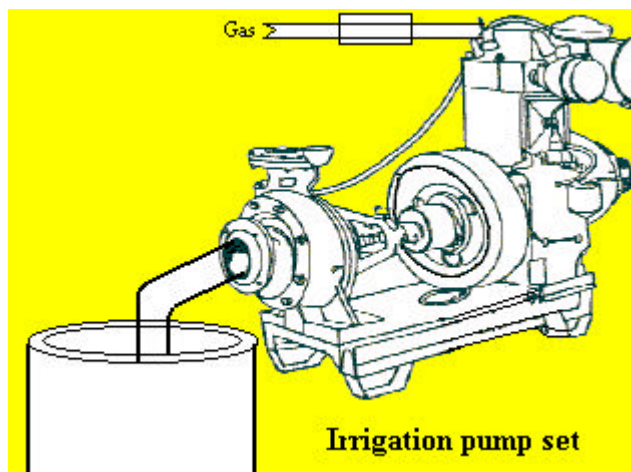

Image

Research in the past shows that compared to gasifiers fueled with wood or agricultural residues, charcoal gasifiers present less operational problems and are recommended for village level applications. Micro scale gasification systems (1-10 kw) can be used by small and medium farmers for providing power to irrigation system. The equipment shall be small, cheap, simple and transportable.

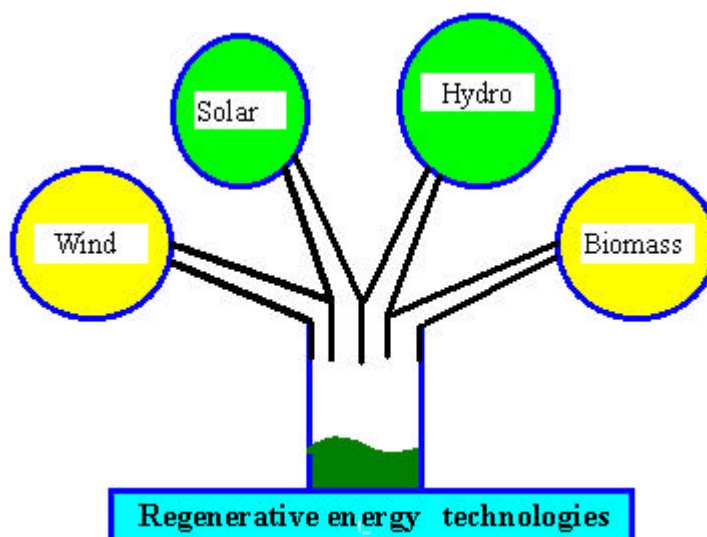

Image

If firewood is available in sufficient amount without any danger to forest, gasifier can serve as an option for energy supply in remote areas. Because of great concern for conservation of forests and availability of fossil fuels, gasification is not seen as universally applicable technology, but act as a component within range of available regenerative energies. It can be a valuable supplement to wind, solar and hydropower.

## Gasification History and Development

The history of gasification dates back to seventeenth century. Since the conception of idea, gasification has passed through several phases of development. Yearwise development of the technology is given below.

1969 Thomas Shirley conducted crude experiments with carborated hydrogen

1699 Dean Clayton obtained coal gas from pyrolytic experiment



- 1788 Robert Gardner obtained the first patent with regard to gasification
- 1792 First confirmed use of producer gas reported, Murdoc used the gas generated from coal to light a room in his house. Since then, for many years coal gas was used for cooking and heating
- 1801 Lampodium proved the possibility of using waste gases escaping from charring of wood
- 1804 Fourcroy found the water gas by reaction of water with a hot carbon
- 1812 developed first gas producer which uses oil as fuel
- 1840 First commercially used gasifier was built in France
- 1861 Real breakthrough in technology with introduction of Siemens gasifier. This gasifier is considered to be first successful unit
- 1878 Gasifiers were successfully used with engines for power generation
- 1900 First 600 hp gasifier was exhibited in Paris. Thereafter, larger engines upto 5400 hp were put into service
- 1901 J.W. Parker run a passenger vehicle with producer gas
- after
- 1901

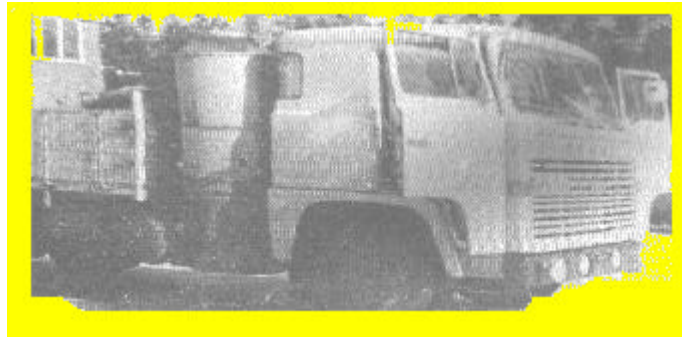

Image

In the period 1901-1920, many gasifier-engine systems were sold and used for power and electricity generation

1930



**Historical gasifiers in Gemany**

Image

Nazi Germany accelerated effort to convert existing vehicles to producer gas drive as part of plan for national security and independence from imported oil

- 1030 Began development for small automotive and portable gas producer. British and French Government felt that automotive charcoal gas producer is more suitable for their colonies where supply of gasoline was scarce and wood that could charred to charcoal was readily available

1939

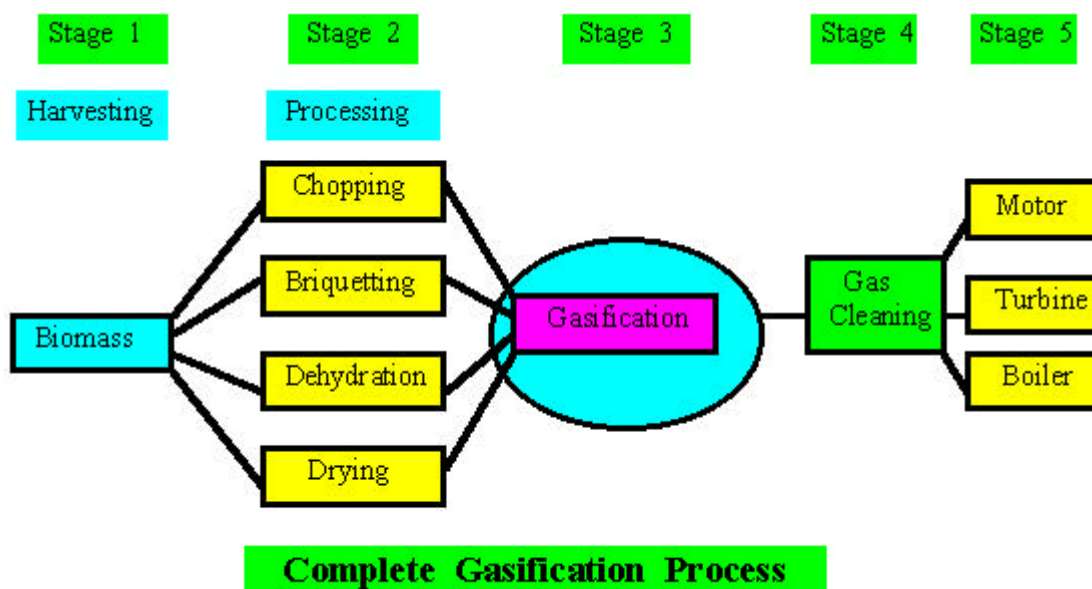

Image

About 2,50,000 vehicles were registered in the Sweden. Out of them, 90 % were converted to producer gas drive. Almost all of the 20,000 tractors were operated on producer gas. 40 % of the fuel used was wood and remainder charcoal

After 1945 After end of second world war, with plentiful gasoline and diesel available at cheap cost, gasification technology lost glory and importance

1945

1950- During this decades, gasification was " Forgotten Technology ". Many governments in europe to felt that consumption of wood at the prevailing rate will reduce the forest, creating several environmental problems

After 1970 The year 1970's brought a renewed interest in the technology for power generation at small scale. Since then work is also concentrated to use fuels other than wood and charcoal.

### Gasification Process

The essence of gasification process is the conversion of solid carbon fuels into carbon monoxide by thermochemical process. The gasification of solid fuel is accomplished in air sealed, closed chamber, under slight suction or pressure relative to ambient pressure. Gasification process occuring in general explained in this section.

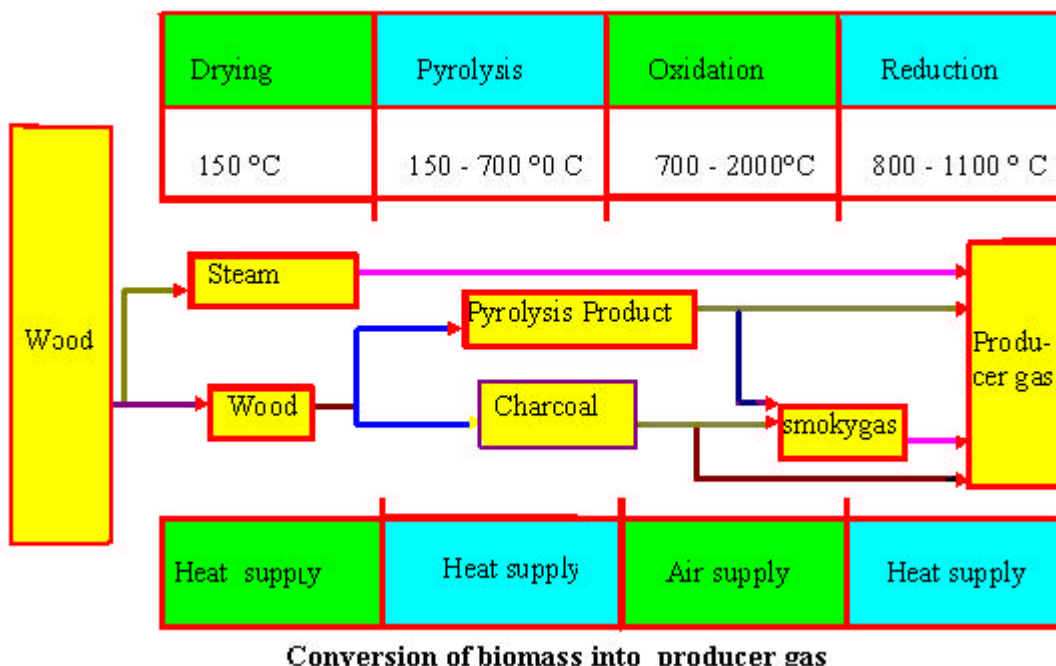

Image

Gasification is quite complex thermochemical process. Splitting of the gasifier into strictly separate zones is not realistic, but nevertheless conceptually essential. Gasification stages occurs at the same time in different parts of gasifier.

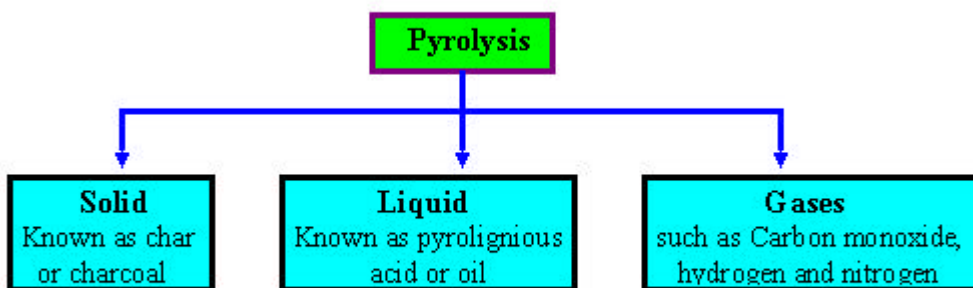

Image

**Drying**

Biomass fuels consist of moisture ranging from 5 to 35%. At the temperature above 100°C, the water is removed and converted into steam. In the drying , fuels do not experience any kind of decomposition.

**Pyrolysis**

Pyrolysis is the thermal decomposition of biomass fuels in the absence of oxygen. Pyrolysis involves release of three kinds of products : solid, liquid and gases. The ratio of products is influenced by the chemical composition of biomass fuels and the operating conditions. The heating value of gas produced during the pyrolysis process is low (3.5 - 8.9 MJ/m<sup>3</sup>).

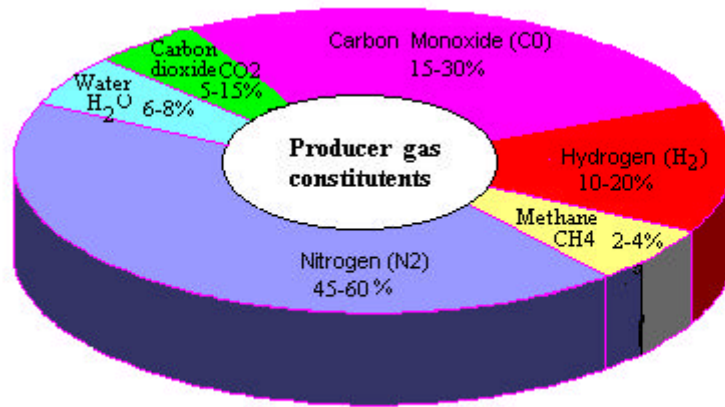

## Image

It is noted that no matter how gasifier is built, there will always be a low temperature zone, where pyrolysis takes place, generating condensable hydrocarbon.

## Oxidation

Introduced air in the oxidation zone contains, besides oxygen and water vapours, inert gases such as nitrogen and argon. These inert gases are considered to be non-reactive with fuel constituents. The oxidation takes place at the temperature of 700-2000<sup>o</sup> c.

Heterogenous reaction takes place between oxygen in the air and solid carbonized fuel, producing carbon monoxide. Plus and minus sign indicate the release and supply of heat energy during the process respectively

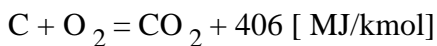

In reaction 12.01 kg of carbon is completely combusted with 22.39 m<sup>3</sup> of oxygen supplied by air blast to yield 22.26 m<sup>3</sup> of carbon dioxide and 393.8 MJ of heat.

Hydrogen in fuel reacts with oxygen in the air blast, producing steam .

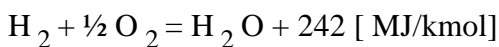

## Reduction

In reduction zone, a number of high temperature chemical reactions take place in the absence of oxygen. The principal reactions that takes place in reduction are mentioned below.

Boudouard reaction



Water-gas reaction

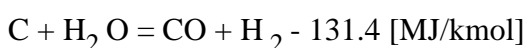

Water shift reaction

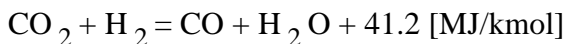

Methane production reaction

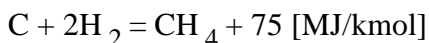

Main reactions show that heat is required during the reduction process. Hence, the temperature of gas goes down during this stage. If complete gasification takes place, all the carbon is burned or reduced to carbon monoxide, a combustible gas and some other mineral matter is vaporized. The remains are ash and some char (unburned carbon)

### Producer Gas and it's Constituents

Producer gas is the mixture of combustible and non-combustible gases. The quantity of gases constituents of producer gas depends upon the type of fuel and operating condition.

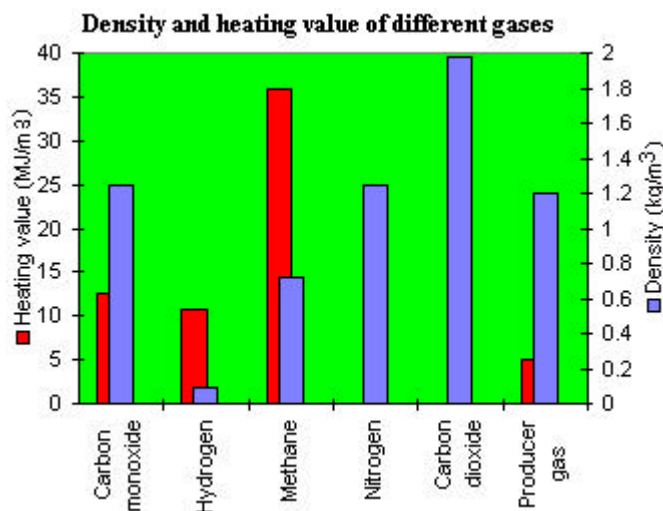

Image

The heating value of producer gas varies from 4.5 to 6 MJ/m<sup>3</sup> depending upon the quantity of it's constituents. Carbon monoxide is produced from the reduction of carbon dioxide and it's quantity varies from 15 to 30 % by volume basis . Although carbon monoxide posses higher octane number of 106, it's ignition speed is low. This gas is toxic in nature. Hence, human operator need to be careful while handling the gas .

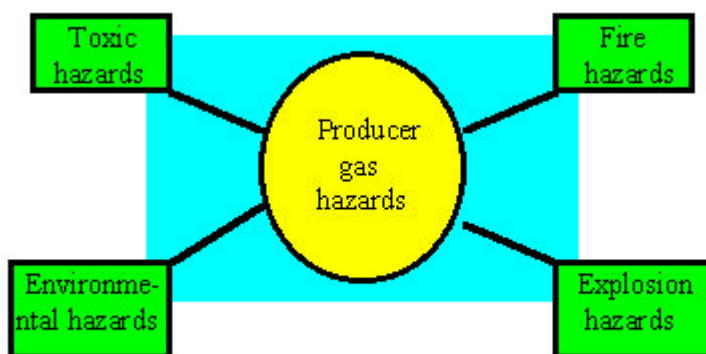



## Image

Hydrogen is also a product of reduction process in the gasifier. Hydrogen possesses the octane number of 60-66 and it increases the ignition ability of producer gas. Methane and hydrogen are responsible for higher heating value of producer gas. Amount of methane present in producer gas is very less (upto 4 %). Carbon dioxide and nitrogen are non-combustible gases present in the producer gas. Compared to other gas constituents, producer gas contains highest amount ( 45-60 %)of nitrogen. The amount of carbon dioxide varies from 5 to 15 %. Higher percentage of carbon dioxide indicates incomplete reduction . Water vapours in the proudcer gas occurs due to moisture content of air introduced during oxidation process, injection of steam in gasifier or moisture content of biomass fuels.

## Hazards with Producer Gas

Sources of fire hazards
High sur face temperatue
Sparks during refuelling
Flames through gasifier

## Image

Producer gas, the mixture of carbon monoxide, hydrogen, methane and other gases, is hazardous, if it is not handled and used properly. Poisonous component of producer gas is carbon monoxide. All hazards associated with use of producer gas are described here.

## Fire hazards

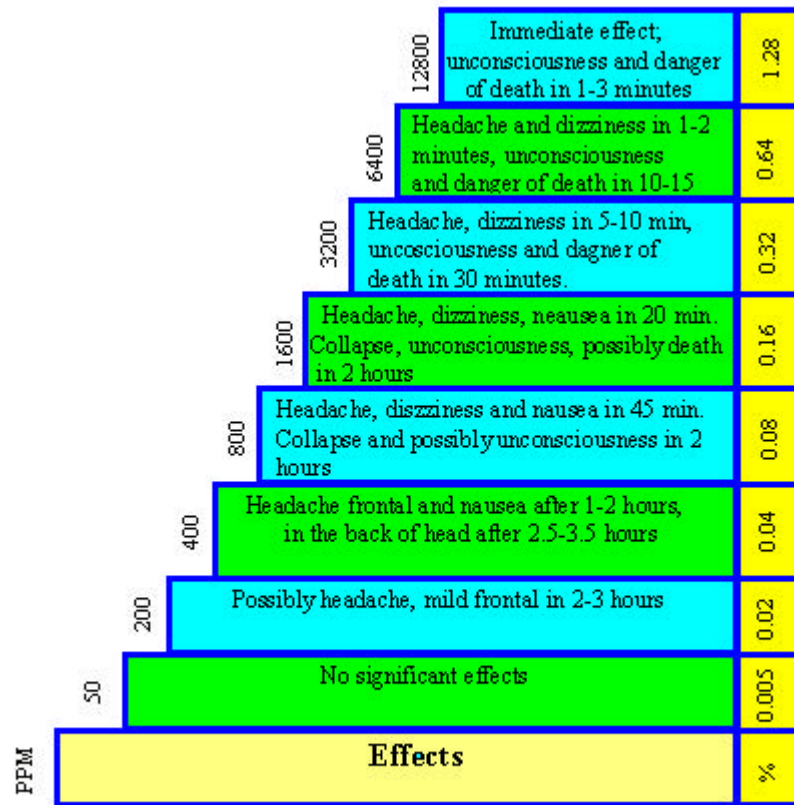

**Poisonous steps of carbon monoxide**

Image

Fire risks can be minimized by taking following precautions

- Insulation of hot parts of system
- Insulation of double sluice filling device
- Installation of back-firing valve in gasifier inlet

Explosion hazards

Explosion can occur if the producer gas is mixed with sufficient amount of air to form explosive mixture. This may happens because of following several reasons :

- Air leakage into the gas system
- Air penetration during refuelling
- Air leakage into cold gasifier still containing gas which can ignite

Air leakage into the gas system does not generally give rise to explosions. To avoid the chance of explosion due presence of producer gas, if any, in cold system, it is necessary to ventilate cold system before igniting the fuel.

**Toxic hazards**

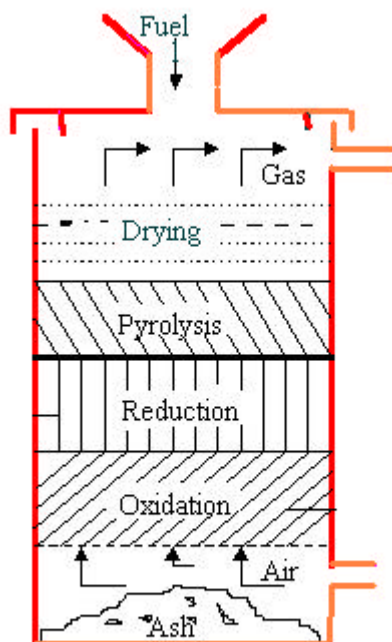

## Image

Producer gas consists of carbon monoxide, which is extremely toxic and dangerous as it combines with haemoglobin in the blood, preventing oxygen absorption and distribution. Carbon monoxide concentration of 50 PPM produces no effect. As concentration increases, there arise problems of headache, dizziness and even death also. No chronic symptoms can occur as the result of prolonged inhalation of relatively small amounts of carbon monoxide. Fortunately, there is less chance of gas escape during operation as gasification system works under suction. However, situation is quite different during starting and closing installations. To avoid the trapping of gas, it is recommended to install the gasifier plant in the open air.

## Environmental hazards

During the gasification of biomass, ashes and condensate (mainly water) are produced. Ashes do not contribute to any environmental hazards and can be safely disposed. However, for the tar-containing condensate, the situation is different and disposal of those forms can have undesirable environmental effects. No specific information is available about the bio-degradation of the phenolic and tarry constituents of the condensates. Properties of exhaust emission of engines running on producer gas is generally acceptable.

## Gas Producers (Gasifiers)

Design of gasifier depends upon type of fuel used and whether gasifier is portable or stationary. Gas producers are classified according to how the air blast is introduced in the fuel column. History of gasification reveals several designs of gasifiers. The most commonly built gasifiers are classified as :

## Updraft gas producer

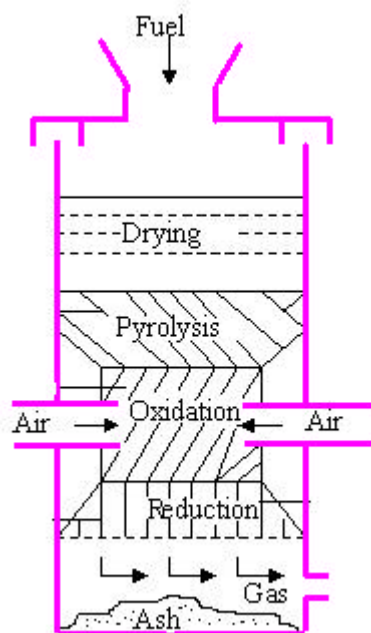

An updraft gasifier has clearly defined zones for partial combustion, reduction, and pyrolysis. Air is introduced at the bottom and act as countercurrent to fuel flow. The gas is drawn at higher location. The updraft gasifier achieves the highest efficiency as the hot gas passes through fuel bed and leaves the gasifier at low temperature. The sensible heat given by gas is used to preheat and dry fuel. Disadvantages of updraft gas producer are excessive amount of tar in raw gas and poor loading capability. Hence it is not suitable for running vehicle.

Image

### Downdraft gas producer

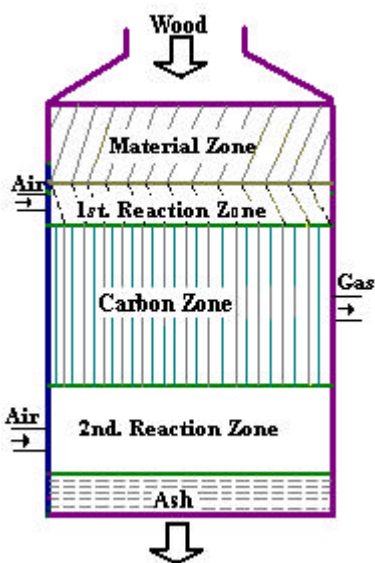

In the updraft gasifier, gas leaves the gasifier with high tar vapour which may seriously interfere the operation of internal combustion engine. This problem is minimized in downdraft gasifier. In this type, air is introduced into downward flowing packed bed or solid fuels and gas is drawn off at the bottom. A lower overall efficiency and difficulties in handling higher moisture and ash content are common problems in small downdraft gas producers. The time (20-30 minutes) needed to ignite and bring plant to working temperature with good gas quality is shorter than updraft gas producer. This gasifier is preferred to updraft gasifier for internal combustion engines

Image

### Twin-fire gas producer

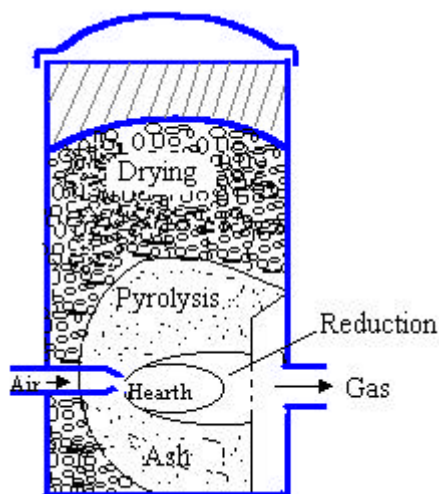

The advantage of co-current and counter-current gasifiers are combined in a so called twin-fire gasifier. It consists of two defined reaction zones. Drying, low-temperature carbonisation, and cracking of gases occur in the upper zone, while permanent gasification of charcoal takes in lower zone. The gas temperature lies between 460 to 520 ° C. Total process takes place with under pressure of -30 mbar. Twin-fire gasifier produces fairly clean gas.

Image

### Crossdraft gas producer

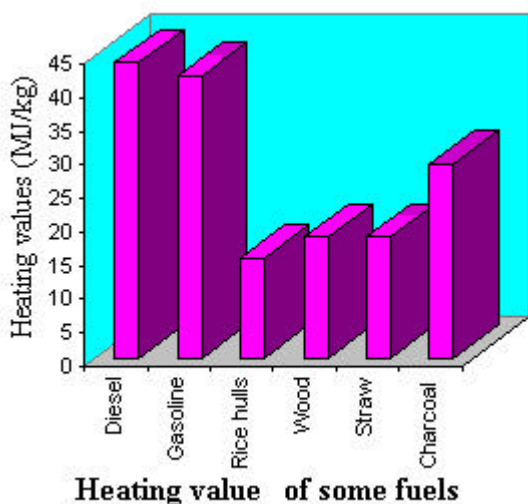

Image

Crossdraft gas producers, although they have certain advantages over updraft and downdraft gasifiers, they are not of ideal type. The disadvantages such as high exit gas temperature, poor CO<sub>2</sub> reduction and high gas velocity are the consequence of the design. Unlike downdraft and updraft gasifiers, the ash bin, fire and reduction zone in crossdraft gasifiers are separated. This design characteristics limit the type of fuel for operation to low ash fuels such as wood, charcoal and coke. The load following ability of crossdraft gasifier is quite good due to concentrated partial zones which operates at temperatures up to 2000 ° c. Start up time (5-10 minutes) is much faster than that of downdraft and updraft units. The relatively higher temperature in cross draft gas producer has an obvious effect on gas composition such as high carbon monoxide, and low hydrogen and methane content when dry fuel such as charcoal is used. Crossdraft gasifier operates well on dry air blast and dry fuel.

### Other gas producers

Although updraft, downdraft or crossdraft gas producers have been the most commonly built types, there is a wide variety of gasifiers which do not really fit into any of these categories and are classified as other gas producers . Some units are built to combine the advantages of crossdraft with downdraft or updraft gas producers.

### Impact of Fuel Properties on Gasification



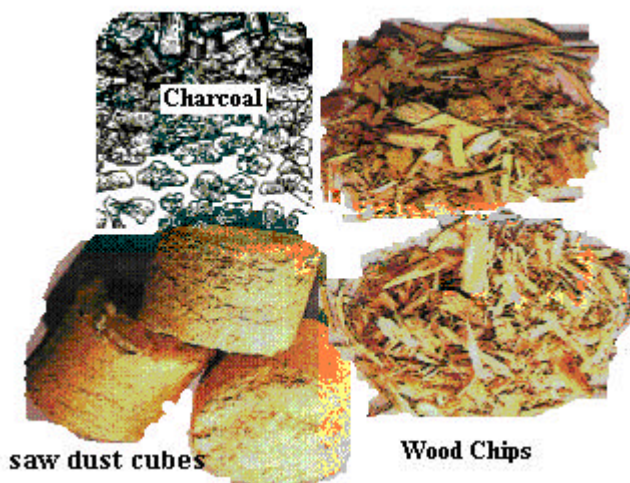

A wide range of biomass fuels such as wood, charcoal, wood waste (branches, roots, bark, saw dust) as well agricultural residues- maize cobs, coconut shells, cereal straws, rice husks, can be used as fuel for biomass gasification. Theoretically, almost all kinds of biomass with moisture content of 5-30% can be gasified; however, not every biomass fuel lead to the successful gasification. Most of the development work is carried out with common fuels such as coal, charcoal and wood. Key to a successful design of gasifier is to understand properties and thermal behaviour of fuel as fed to the gasifier. The properties of fuel which influence the gasification are described below.

Image

### Energy content of fuel

Energy content of fuel is obtained in most cases in an adiabatic, constant volume bomb calorimeter. The values obtained are higher heating values which include the heat of condensation from water formed in the combustion of fuel. The heating values are also reported on moisture and ash basis. Fuel with higher energy content is always better for gasification. The most of the biomass fuels (wood, straw) has heating value in the range of 10-16 MJ/kg, whereas liquid fuel (diesel, gasoline) posses higher heating value.

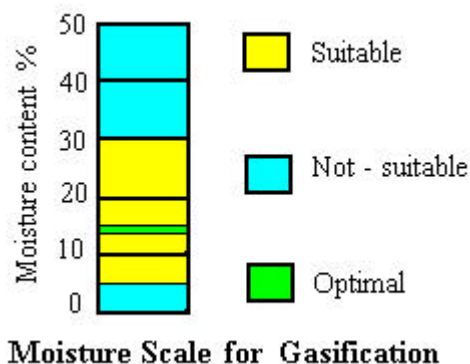

Image

### Fuel moisture content

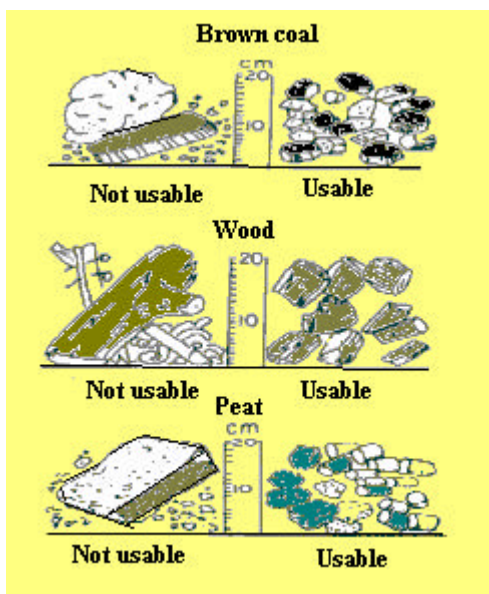

The moisture content of the most biomass fuel depends on the type of fuel, its origin and treatment before it is used for gasification. Moisture content of the fuel is usually referred to inherent moisture plus surface moisture. The moisture content below 15% by weight is desirable for trouble free and economical operation of the gasifier. Higher moisture contents reduce the thermal efficiency of gasifier and results in low gas heating values. Igniting the fuel with higher moisture content becomes increasingly difficult, and the gas quality and the yield are also poor .

Image

### Particle size and distribution

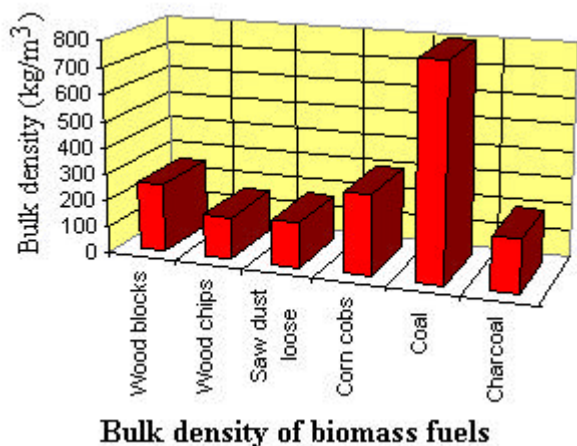

The fuel size affect the pressure drop across the gasifier and power that must be supplied to draw the air and gas through gasifier. Large pressure drops will lead to reduction of the gas load in downdraft gasifier, resulting in low temperature and tar production. Excessively large sizes of particles give rise to reduced reactivity of fuel, causing start-up problem and poor gas quality.

Acceptable fuel sizes depend to certain extent on the design of gasifier. In general, wood gasifier work well on wood blocks and wood chips ranging from 80x40x40 mm to 10x5x5 mm. For charcoal gasifier, charcoal with size ranging from 10x10x10 mm to 30x30x30 mm is quite suitable.

Image

### Bulk density of fuel

Bulk density is defined as the weight per unit volume of loosely tipped fuel. Bulk density varies significantly with moisture content and particle size of fuel. Volume occupied by stored fuel depends on not only the bulk density of fuel, but also on the manner in which fuel is piled. It is also recognised that bulk density has considerable impact on gas quality, as it influences the fuel residence time in the fire box, fuel velocity and gas flow rate.



saw dust cubes

Image

**Fuel form**

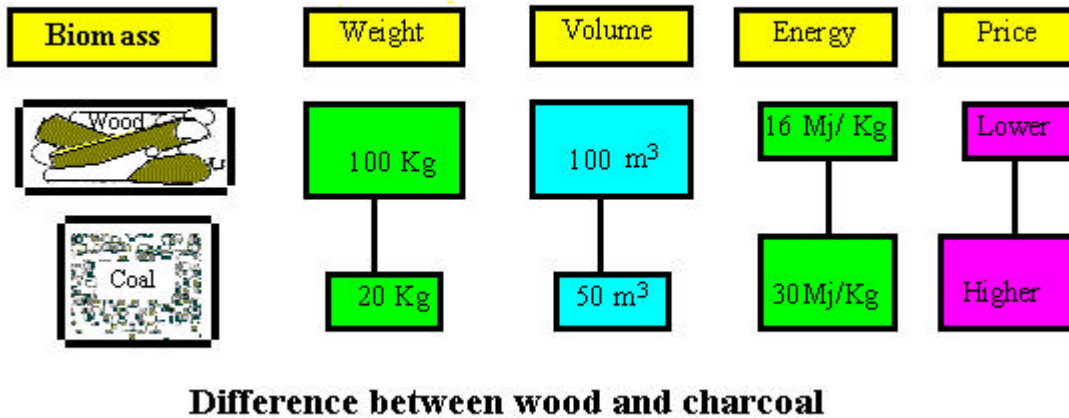

Image

The form which fu is fed to gasifier h an economica impact ( gasification). Densifying biomass h been practiced the US f the past 4 years. Cupers at Pelletizers densify a kinds of biomass at municipal waste into energy cubes". These cub are availab in cylindrical or cubic form and have a hi; density 600-1000 kg/m<sup>3</sup>. Tl specific volumetric content cubes is much high

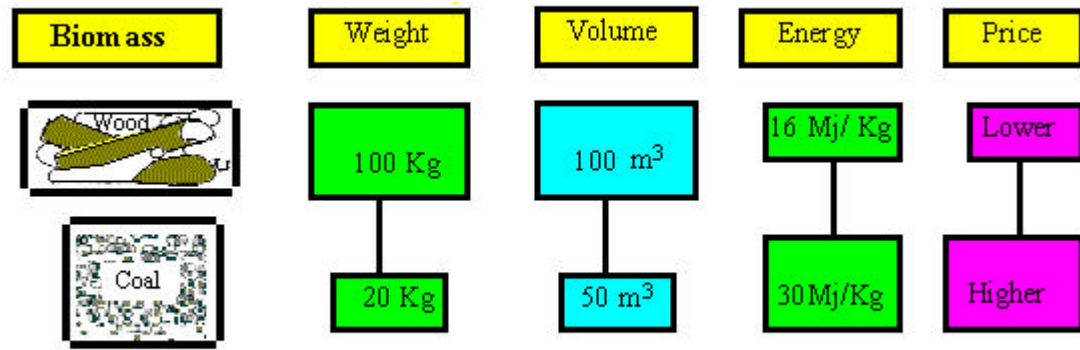

**Difference between wood and charcoal**

Image

The form in which fuel is fed to gasifier has an economical impact on gasification. Densifying biomass has been practiced in the US for the past 40 years. Cupers and Pelletizers densify all kinds of biomass and municipal waste into "energy cubes". These cubes are available in cylindrical or cubic form and have a high density of 600-1000 kg/m<sup>3</sup>. The specific volumetric

content of  
cubes is  
much higher  
than the raw  
material  
from which  
they are  
made.



[View this page in text format](#)



than the ra  
material  
from whi  
they are  
made.

### Volatile matter content of fuel

Volatite matter and inherantly bound water in the fuel are given up in pyrolyis zone at the temperatures of 100-150°C forming a vopour consisting of water, tar, oils and gases. Fuel with high volatile matter content produces more tar, causing problems to internal combustion engine. Volatile matters in the fuel determine the design of gasifier for removal of tar. Compared to other biomass materials (crop residue : 63-80 %, Wood : 72-78 %, Peat : 70 %, Coal: upto 40 % ), charcoal contains least percentage of volatile matter (3-30 %)

### Ash content of fuel

Mineral contents of fuel which remians in oxidized form after combustion of fuel is called ash. In practice, ash also contain some unburned fuel. Ash content and ash composition have impact on smooth running of gasifier. Melting and agglormeration of ashes in reactor causes slagging and clinker formation. If no measures are taken, slagging or clinker formation lead to excessive tar formation or complete blocking of reactor. In general, no slagging occurs with fuel having ash content below 5 %. Ash content varies fuel to fuel. Wood chips has contains 0.1% ash, while rice hust contains high amount of ash (16-23%)

### Fuels and their ash content

Fuel	Ash content % weight	Fuel	Ash content % weight
Alfalfa seed straw	6.0	peanut husks	0.9
Barley straw	10.3	Rice hulls	16-23
Charcoal	2-5	Safflower straw	6.0
Coffee hulls	1.3	Wallnut shell	1.1
Coal	5-17	Wheat stalks	7.4
Cotton grin thrash	17.2	Wood chips	0.1

### Reactivity of fuel

Reactivity determines the rate of reduction of carbon dioxide to carbon monoxide in the gasifier. Reactivity depends upon the type of fuel. It has found that wood and charcoal are more reactive than coal. There is relationship between reactivity and the number of active places on the char surfaces.

It is well known fact that reactivity of char surface can be improved through various processes including stream treatment (activated carbon) or treatment with lime and sodium carbonate. There are number of elements which act as catalyst and influence the gasification process. Small quantities of potassium, sodium and zink can have large influence on reactivity of the fuel.

### Suitability of Some Biomass Fuels

The quality of producer gas depends upon the several factors including type of fuel. The assessment

of suitability of some of the important biomass fuels for gasification is given below

## Charcoal

Charcoal is a product of wood carbonisation (absence of air). By burning around 5 ton of firewood, 1 ton of charcoal is produced. Charcoal offers twice as much heat as wood. Energy lost during the conversion of wood to charcoal can be compensated by using efficient charcoal oven or cookstove. Unlike firewood, it burns slowly and does not produce any smoke



Image

Good quality charcoal does not contain any tar, hence it is quite feasible for all kinds of gasifiers. Charcoal is also low in mineral matter and does not disintegrate easily. Compared to other biomass fuels, charcoal is costly. Important disadvantage is that during conversion of wood into charcoal, more than 50% of energy is lost. This is a notable factor for those developing countries which suffer in energy crisis.

## Wood

The main combustible components of wood are cellulose and lignine which are compounds of carbon, hydrogen and oxygen. Other minor combustible components in wood are resins and waxes. The major non-combustible component of wood is water which is present up to 50 % in freshly cut wood. Though the ash content is low (less than 1 %), but because of high oxygen content, the calorific value is low (16-20 MJ/kg).

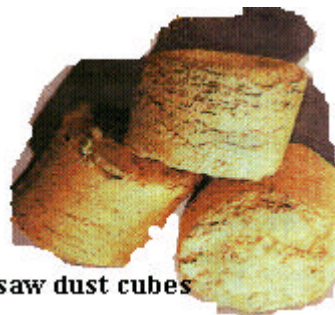

Image

Next to charcoal, wood is quite suitable fuel for fixed bed gasifiers. As wood contains high volatile matter, updraft gasifier system produce the gas containing tar, which need to be cleaned before using in engines. Cleaning of gas is difficult and labour intensive process. Hence, wood is not suitable in updraft gasifier coupled with internal combustion engines. However, the gas containing tar from updraft gasifier can be used for direct burning.

Downdraft can be designed to produce relatively tar-free gas. After passing the gas through simple clean-train, it can be used in the internal combustion engines.

## Sawdust



saw dust cubes

Unpellatized sawdust lead to the problems of excessive tar production, inadmissable pressure drop and lack of bunker flow. Such problems can be minimized by use of densified (pelletized) sawdust. Small sawdust particles can be used in fluidized gas proucers to produce burning gas. If this gas is used to be in internal combustion engines, fairly good clean-up system is essential.

Image

## Peat

Peat is the first stage of coal formation. It is not strictly a coal or it can be termed as the most immatured coal. Freshly mined peat contains 90 % moisture and 10 % of solid. It cannot be utilised unless air dried to reduce moisture content to 30 % or less. Its heating value (around 20 MJ/kg) is slightly greater than wood.

As peat contains very high level of moisture and ash, it creates problems in the gasification process. Small downdraft gasifiers fueled with dry peat-pallets have been successfully tested in gas-engine system.

## Agricultural residues

If wood is scarce and costly, more abundant or accessible but otherwise less favoured fuels is used instead. Agricultural residues are basically biomass materials that are by product of agriculture. It includes cotton stalks, wheat and rice straw, coconut shells, maize and jowar cobs jute sticks, rice husks etc.

Many developing countries have a wide variety of agricultural residues in ample quantities. Coconut shells and maize cobs have been successfully tested for fixed bed gasifiers and they unlikely creates any problems. Most cereal straws contains ash content above 10% and present slagging problem in downdraft gasifier. Rice husk with ash contents above 20% is difficult to gasify.

## Producer Gas Drive Engines

Producer gas is used in internal combustion engine for power or electricity generation. Internal combustion engines are normally designed to run on diesel or gasoline fuel. Properties of of producer gas- mixture is different from that of diesel or gasoline. Use of producer gas in internal combustion engines affects performance and other maintenace features of engines. This sections deals with various following issues concerned with use of producer gas in internal combustion engines.

## Peformance of gasifier-engine system

Cold gas efficiency of producer gas in favourable condition can be 70%. In gasifier-engine system, losses also occurs at different stages. Engine performance is expressed in terms of brake thermal efficiency. Overall efficiency of the system is the product of gasifier efficiency and brake thermal efficiency.

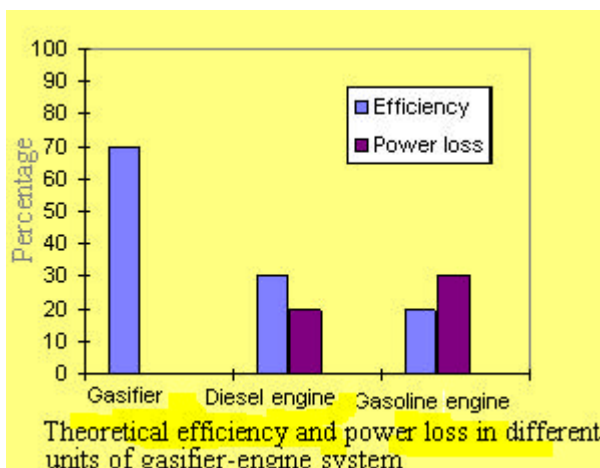

Image

The actual efficiency of engine varies with design, size and running condition. Efficiency of diesel and gasoline engines under good condition are considered to be 30% and 20% respectively. The efficiency of engine run with producer gas goes down owing to lower density of gas-air mixture and other power losses associated with suction of mixture in engines. Theoretically, gasoline and diesel engine operated on producer gas suffer a power loss of 30% and 20 % respectively. In practice, considering a wide range of producer gas quality, a power drop ranging from 25 % to 60 % can be expected when diesel or gasoline engine is run with producer gas

A typical composition of 4.5% CO<sub>2</sub>, 27 % CO, 14% H<sub>2</sub>, 3 % CH<sub>4</sub> and 51% N<sub>2</sub> has a lower heating value of 5.7 MJ/m<sup>3</sup> at normal ambient condition of 15° C and pressure of 1 atm . The stoichiometric gas-mixture has an energy density of 2.5 MJ/m<sup>3</sup> compared to 3.5 MJ/m<sup>3</sup> for gasoline-air mixture and 3.3 MJ/m<sup>3</sup> diesel-air mixture.

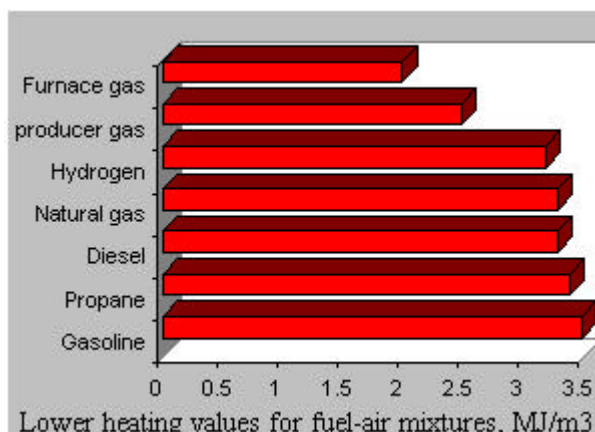

Image

### Operational difference between diesel and gasoline engine

There is significant difference between diesel and spark ignition engine system with respect to it's suitability for producer gas. In diesel engine, diesel is injected at the end of compression stroke and get ignited immediately without any spark ignition. This will not the case with producer gas- air mixture. In fact, diesel engine cannot operate alone on producer gas as temperature and pressure is not sufficient to ignite gas-air mixture. Hence, during the injection of producer-gas mixture, some quantity of diesel is also injected in combustion chamber.

#### Diesel Engine

- Fuel : Diesel**
- Compression ratio : 16-24**
- Ignition : Compression**
- Efficiency : 25-35 %**

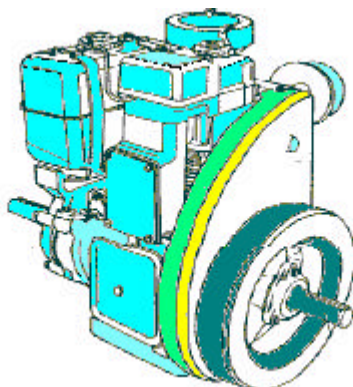

#### Gasoline Engine

- Fuel : Gasoline**
- Compression ratio : 5-10**
- Ignition : Spark**
- Efficiency : 15-25 %**

Image

In gasoline engine, air-fuel mixture is sucked during suction stroke and mixture is ignited with a spark at the end of compression stroke. Gasoline engine running on producer gas can operate on producer gas alone without any injection of gasoline. This is certainly convenient in remote rural areas, where gasifier-engine system is used for power or electricity generation. In general, low speed engines with large displacement and combustion place have advantage over today's compact and high speed engines.

### Conversion of gasoline engine to producer gas

Unaltered gasoline engine run with producer gas experiences the power loss of 30-50% depending upon the producer gas quality.

Unaltered gasoline engine run with producer gas sound good from economical point of view. This approach is beneficial, for some application such as irrigation pump, which works at constant load and even at low load also. This approach is not practically workable for tractor or any other automobile which has to work under different loading condition.

In case already installed gasoline engine is converted to producer gas drive, some of the power can be recovered through supercharging or turbocharging. The turbocharger would be required to deliver the gas-air mixture into existing unaltered engine at differential pressure of 1 atm to achieve equivalent of compression ratio increase from 5 to 10. This compression can be achieved by reciprocating type of pump. The power for pump shall be provided by turbine run on exhaust of engine.

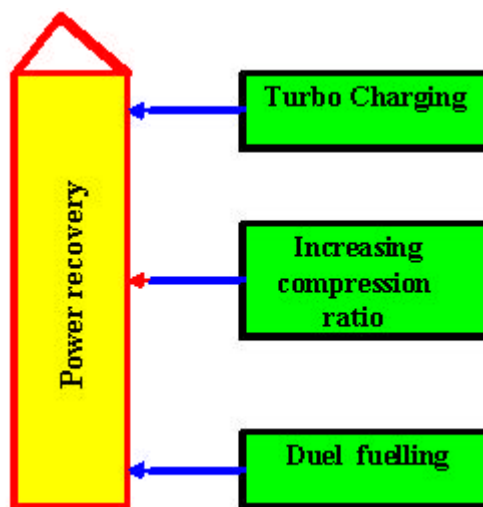

Image

### Compression ratio

Power loss in gasoline engine run on producer gas be recovered by increasing the compression ratio. Commercially built gas producers were usually operated at the compression ratio of 6.5 to 7.5. Keeping in mind hydrogen content in producer gas and its effect on flame speed, compression ratio as high as 10 is said to be technically and economical feasible. There are other operational problems with higher compression ratio. Engine with higher compression ratio are difficult to start, creates vibrations, increases wear and tear on piston, reducing the life of the system.

### Gas-fuel mixture



In the case of engine run on gasoline, gasoline-air mixture is adjusted automatically by carburetor and controlled by accelerator. Finding the correct gas-air ratio in producer gas drive engine is difficult as gas composition changes over a run, sometimes drastically. There are different kinds of valves ranging from simple hand operated valve to fully automatic valve for control of gas-air mixture.

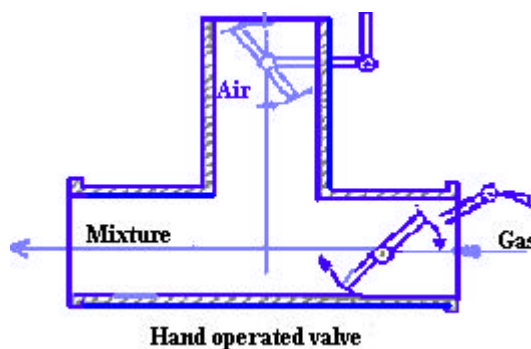

Image

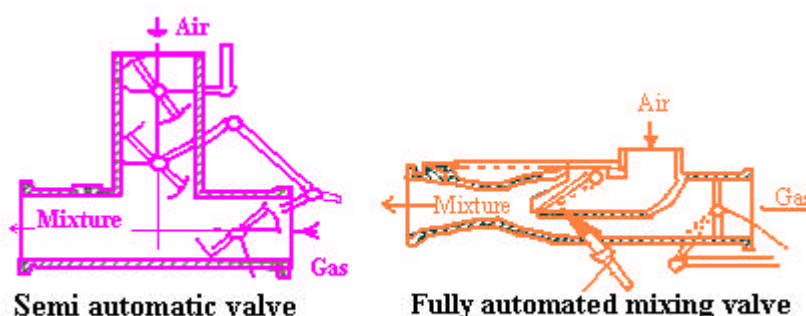

Image

Due fuelling

One of the most widely used and convenient method to increase the power output of engine is dual fuelling. Dual fuelling is good compromise between gasoline savings, convenience and ease of operations. In dual fuelling, gas-air mixture is injected with small amounts of gasoline. Degree of dual fuelling depends upon the engine load and independence one need in use of producer gas. Three commonly used dual fuelling methods are :

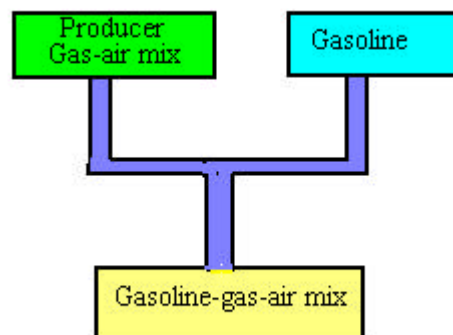

Image

- Dual fuelling on continuous basis, meaning small amounts of gasoline with gas-air mixture
- Starting the engine on gasoline and then switching over to producer gas drive
- Dual fuelling when additional power is needed to overcome the load, for instance, on hills

**Conversion of diesel engine to producer gas**

Diesel engines are compression ignition engines with compression ratio of 16-24 depending on whether they are direct combustion chamber, pre-combustion chamber, four strokes or two strokes. Fuel is ignited by high gas air temperature. As diesel engine cannot be operated on producer gas alone, it need to be operated on dual fuel or converted completely into spark ignition engine.

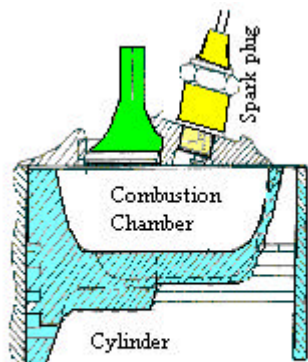

**Complete conversion of diesel engine to gas drive**

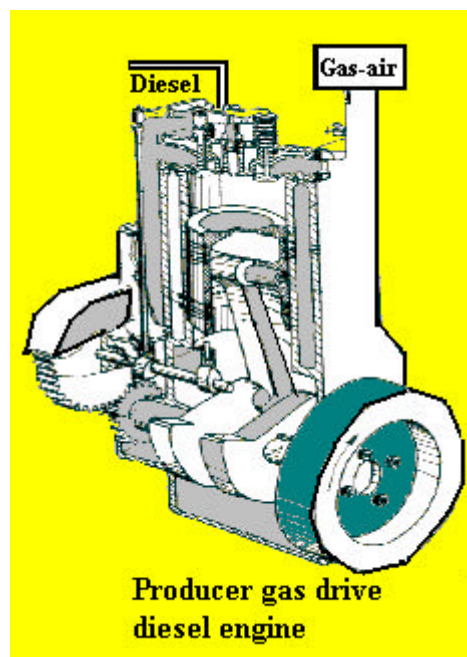

Image

Image

Complete rebuilding of entire engine is expensive and time consuming job. Power drop in diesel engine converted to spark ignition is not as severe as gasoline engine running on producer gas. In case of dual fuelling, modification is confined to a special induction manifold and gas-air mixer as converted in gasoline engines. The pilot injection of diesel amounted to 10 -25% of original consumption. For economical reason, it is best to inject the amount of diesel necessary for smooth operation of engine

### Conditioning of Producer Gas

<b>Producer gas mixture</b>
<b>Useful gases</b>
Carbon monoxide (CO)
Hydrogen (H <sub>2</sub> )
Methane (CH <sub>4</sub> )
Acetelene (C <sub>2</sub> H <sub>2</sub> )
Ethelene (C <sub>2</sub> H <sub>4</sub> )
Ethane (C <sub>2</sub> H <sub>6</sub> )
<b>Destructive elements &amp; gases</b>
Carbon dioxide (CO <sub>2</sub> )
Tar vapour
Water vapour
Mineral vapour
Dust (Carbon, ash)

Producer gas leaves the gasifier as the mixture of combustible and non-cobustible gases alongwith tar vapour, water vapour, dust, mineral vapour. Sulphur compounds such as hydrogen sulphide (H<sub>2</sub>S) and nitrogen compounds (NH<sub>3</sub>, HCN) in producer gas are undesirable as their condensates are corrosive and pollutants in exhaust gases. The generation of H<sub>2</sub>S is of little importance in gasification of biomass as long as sulphur content does not exceed 0.5%. The amount of NH<sub>3</sub> and HCN in the gas depends on the nitrogen content of the fuel. Fuel with nitrogen content less than 2 % is safe for gasification. Silicon oxide (SiO<sub>2</sub>) and iron oxide (Fe<sub>2</sub>O<sub>3</sub>) in dust are important because of their abrasive nature.

Image

For trouble free operation, engine must be supplied with producer gas that is sufficiently free from tars, dust and acids. The cleaning of gas is necessary to avoid wear and tear in engine. Dust concentration in the gas depends upon the type of gasifier, intensity of load and type of fuel. As load increases, dust concentration in producer gas also increases. The removal of tar from gas producer is one of the more difficult problems in gas cleaning.

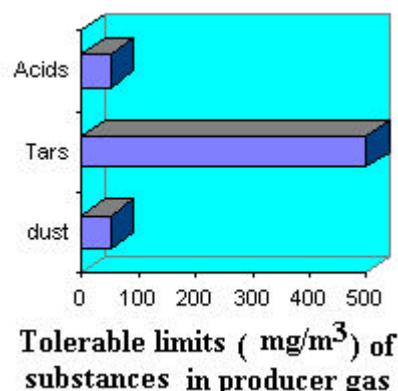

Image

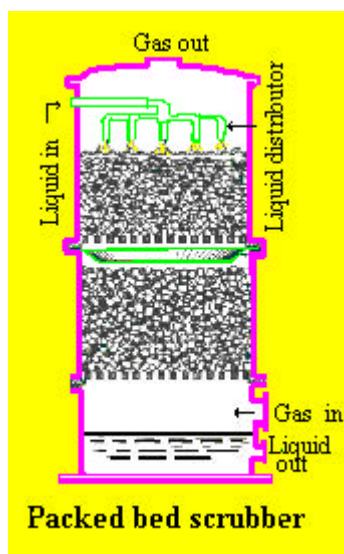

Gas cleaning and cooling for gasifier system is accomplished by a cyclone, a gas cooler with some scrubbing action and a packed bed filter. Gas cooling increases density of gas in order to maximize the amount of gas entering the engine cylinder. Wet scrubbers are used to remove gaseous pollutants and solid particles while cooling the gas at same time. There exists different kinds of scrubbers for small scale producer engine system. A Packing bed scrubber consists of packing, liquid, support grates and distributors plates. Packing can be made from wide range of commercial and home made materials-steel, wool, wood chips, coke, gravel etc. Gas is passed through bottom and removed at top.

Image

Fabric filter is considered to be one of the suitable filters for vehicle application. It is placed immediately after cyclone. In filter with glass-fibre cloth, it is possible to withstand a gas temperature upto 300°C. The performance of filter depends on type of gasifier, fuel moisture content and how vehicle is driven. It is recommended that gas flow rate through filter box shall not exceed 65 m<sup>3</sup>/h. Pressure loss over filter is affected by load and amount of dust in the producer gas.

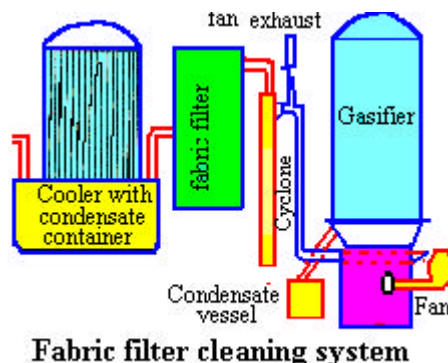

Image

### Troubles with Gasification System

Gasification is quite complex and sensitive process. There exists high level of disagreement about gasification among engineers, researchers, and manufacturers. Many manufacturers claim that their unit can be operated on all kinds of biomass. But it is quite questionable fact as physical and chemical properties varies fuel to fuel.

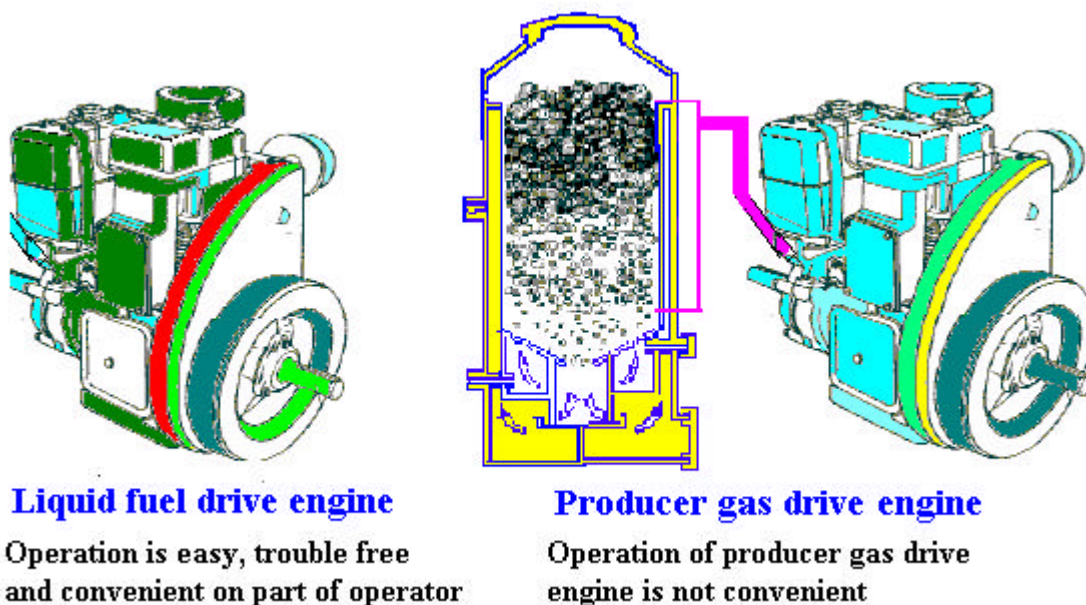

Image

Operation of diesel or gasoline engine is simple. Engine starts immediately and there is no trouble within the run. Handling of liquid fuel is also easy task. Anybody expecting something similar will be disappointed with operation of gasifier. It requires atleast half an hour or more to start the system. Fuel is bulky and frequent refuelling is often required for continuous running of the system. Handling residues such as ash, tarry condensates is time consuming and dirty work. Driving with producer gas fueled vehicles requires much more and frequent attention than gasoline or diesel fueled vehicles

Getting the producer gas is not difficult, but obtaining in the proper state is the challenging task. Gasoline and diesel have quite homogenous property. The physical and chemical properties of producer gas such as energy content, gas composition and impurities vary time to time. All the

gasifiers have fairly strict requirements for fuel size, moisture and ash content. Inadequate fuel preparation is an important cause of technical problems with gasifiers.

Gasifier is too often thought of as simple device that can generate a combustible gas from any biomass fuel. A hundred years of research has clearly shown that key to successful gasification is gasifier specifically designed for a particular type of fuel. Those interested in this technology must remember that it requires hard work and tolerance. Although technology is inconvenient, it is economical at many places and may lead to self-reliance in fuel crisis.

## Literatures on Gasification

**The detail list of research papers, books and other related literatures on gasification is given below. The list is arranged alphabetically by authors name.**

Allcut E.A. , Producer Gas for Motor Transport , Engineering Journal, V 25, n 4, 1942, PP 223-230

Allcut, E.A. and R.H. Patten, Gas Producer For Motor Vehicles, First General Report of the Subcommittee on Producer Gas, National Research Council of Canada, Ottawa, Canada, 1943.

Allcut, E.A., Peoducer Gas for Motor Transport, Engineering Journal, v 25, n 4, 1942, pp 223-230.

Allcut, E.A., Producer Gas for Motor Transport, Automotive and Aviation Industries, v 89, n 9, 1943, pp 38-40, 42,44,60.

Amin , H., Preliminary Evaluation of an Automotive Gas Producer, General Motors Research Publication GMR-3431, F&L-709, Warren, Michigan, September, 1980.

Anderson M., Case for the Encouragement of the Producer - Gas Vehicle in Britain, Fuel Economist, V 14, July, 1938 pp 245-246, 256-257

Anonymous, Rhe soviet Producer - Gas Tractor, Gas and Oil power, March, 1945, pp 89-95

Anonymous , Producer Gas versus Petrol Operation in Germany, Petroleum Times , V 47, n 1193, p 190

Anonymous, The power Guide, Intermediate Technology Publication, London, 175-215, 1994

Annonymous, Wood Gas as Engine Fuel, FAO, Rome, 1986

Anonymous , Gas Producer for Road Vehicles, Engineering, May 26, 1939, pp 631-632

Anonymous , German Portable Gas Producer Practice, Engineering, V 155, May, 1943, pp 423-424

Anonymous , Improvements in the " Brush Koela" Gas Producer, Engineering, v 169, n 4398, 1949, pp 395

Anonymous , Official Specificiation for Portable Gas-Producer Fuels,Engineering February, 1940, p 150

Anonymous, A New Gas Producer - Gas ülant for road Transport, The Commercial Motor , January, 20 , 1933, pp 787-788

Anonymous, Alternative Fuels for Wartime, Gas and Oil power, October 1939, pp 235-238



Anonymous, An Improved Producer, Automobile Engineer, v 30, May 1940, pp 147-148.

Anonymous, Emergency Gas Supplies for Factories, Power and Works Engineer, V 36, June, 1941, pp 137-139

Anonymous, Forest Gas for Traction, Engineer, V 166, n 4311, 1938, pp 230-231

Anonymous Gas as a Substitute for Gasoline part 1, Petroleum Times, V 42, n 1073, 1939, pp 169-170,189.

Anonymous, Converting Diesels for Producer Gas Working , Bus and Coach, January, 1943, pp 13-24.

Anonymous, Discussion on Tests on Transport Producer- Gas Units, Discussion in London on the paper by H. Heywood, Meeting of the Institution of Automobile Engineers, July, 24, 1942, Institution of Automobile Engineers, v 149, p 34.

Anonymous, Gas Producer Tests, Automobile Engineer, v 32, n 417, 1941, pp. 418-420.

Anonymous, Gas Producer Tests, Automobile Engineer, v 31, n 417, 1941, pp 418-420.

Anonymous, Gas Producer, Automobile Engineer, November 5, 1942, pp. 433-464.

Anonymous, Gas Producers, Automobile Engineer, November, 1942, pp 433-464.

Anonymous, Gas Producers: Modified Governemnt Plant, Automobile Engineer, November, 1943, pp. 433-464.

Anonymous, Gasification Project, Utimate Chemical Analysis log, Agricultural Engineering Department, University of California, Davis, 1979.

Anonymous, Generator Gas the Swedish Experience from 1939-1945, Solar Energy Research Institute, Golden, Colorado, SERI/SP 33-140, January 1979.

Anonymous, Producer Gas : Present and Future, Gas and Oil power, v 40, n 473,  
pp 49-50

Anonymous, Producer Gas for Road Vehicles , Engineering v 163, n 4248, 1937,  
pp. 682-684.

Anonymous, Producer Gas for Road Vehicles, Engineer, V 163, n 4248, 1937,  
pp 682-684.

Anonymous, Alternative Fuels for Motor Vehicles, Engineering, V 148, n 3847m 1939. pp. 387-388.

Anonymous, Gas Utilization for Automobiles, Gas Age, December 7, 1939

Anonymous, Producer Gas plant Manufacture, Gas and Oil power, v 37, n 443, 1942, pp 147-150

Anonymous, Producer Gas, Automobile Engineer, v 26, n 352, 1936, pp 475-478.

Anonymous, The P.S.V. Gas Producer, Bus and Coach, November, 1942, pp 228- 230

Anonymous, The Tulloch- Reading Gas Producer for Motor Vehicles Engineering, v 127, May. 1929, pp 641-644.

Asplund, D., Peat as a Source of Energy in Finland, Peat as a Fuel, Finn Energy 79 Seminar, The state Fuel Centre, Jyväskylä, Finland, January, 1979.

Bailey, M.L., Gas Producer for Motor Vehicles: A Review, Department of Scientific and Industrial Research, Chemistry Division, Report CD 2279, New Zealand , 1979

Bailie, R.C., Current Developments and Problems in Biomass Gasification, Sixth Annual Meeting, Biomass Energy Institute, Winnipeg, Manitoba, Canada, October, 1977.

Bailie, R.C., Current Developments and Problems in Biomass Gasification Sixth Annual Meeting Biomass Energy Institute, Winnipeg, Manitoba, Canada, October, 1977.

Bainbridge, J.R., The Road Performance of Motor Vehicles Operated on Charcoal Producer Gas, The Modern Engineer, March 1942, pp 25-32.

Baron, R.E., Chemical Equilibria in Carbon- Hydrogen- Oxygen Systems, MIT Press, Cambridge, Massachusetts, 1977.

Billings, C.E. and J. Wilder, Handbook of Fabric Filter Technology, Vol.1, GCA Corporation, 1970.

Blackwood, J.D. and F. McGrory, The Carbon-Steam Reaction at High pressure, Australian Journal of Chemistry, v 10, 1957, pp. 16-33.

Bowden, A.T., Bench and Field Tests of Vehicle Gas Producer Plant as Applied to Farm Tractors, Institute of Mechanical Engineering, University of Western Australia, v 146, 1941, pp 193-207.

Bowden, A.T., Discussion on Bench and Field Tests on Vehicle Gas Producer plant, Institution of Mechanical Engineers, Australia, v 148, 1942, pp 65-70.

Branders, H.A., Producer Gas is the Motor Fuel of Finland, Automotive Industries, May, 1941, pp 482-485, 522-523.

Breag, G.R. and A. E. Chittenden , Producer Gas: Potential and Application in Developing Countries, Tropical Producers Institute, Report GI30, London, England, 1979.

Brownlie, D., Producer Gas Driven Vehicles, The Iron and Coal Trades Review, January, 1940, pp 121-123.

Bugge, G., Industrie der Holzdistillationsprodukte, Theodor Steinkopff Company, Leipzig, East Germany, 1927.

Bulcraig, W.R., Components of Raw Producer Gas, Institute of Fuel Journal, v 34, n 246, 1961, pp. 280-283.

Calvert, Seymour, et al., Wet Scrubber System Study, Volume I: Scrubber Handbook, U.S. Department of commerce, NTIS PB-213 016, August, 1972.

Campbell , J.L., Gas Producers: An Outline of the Compulsory Government Tests in Australia, Automobile Engineer, v 32, n 422, 1942, pp 156-158

Campbell, J.L., Gas Producers: An Outline of the Compulsory Governemnt Tests in Australia, Automobile Engineer, v 32, n 422, 1942, pp 156-158.

Caram, H.S. and N.R. Amundson, Diffusion and Reaction in a stagbant Boundary Layer About A Carbon Particle, Part 1, Ind. Eng Chem. Fundam. v 16, n 2, 1977, pp. 171-181.

Caram, H.S., and N.R., Amundson, Diffusion and Reaction in a stagnant Noundary Layer about a Carbon Particle, Part 1 , Ind. Eng. Chem. Fundam., v 16 , n 2, 1977, pp 171-181.

Clarke, J.S., The Use of Gas as a Fuel for Motor Vehicles, Institute of Fuel, Journal, v 83,n 10, 1940, pp 102-117.

Corey, R.C., Measurement and Significance of the Flow Properties of Cpap-Ash Slag, U.S. Department of Interior, Bureau of Mines, Bulletin 618,1964.

Cruz, I.E., A Status Report on Studies, Conducted by College of Engineering on Alternative Fuels for Internal Combustion Engines, University of Philippines, Mechanical Engineering, Diliman, Quezon City , 1980.

Danielson, J.A., Air Pollution Engineering Manual , U.S. Department of Health, Education and Welfare, Cincinnati, Ohio, 1967.

DeGraaf , J.E., A Note on variation in Producer-Gas Quality, Iron and Steel Institute. Journal, v 157, October 1947, pp 183-190.

Dimitryew, A.P., Automotive Gas Geberation Used in USSR, Automotive Industries, v 83, n 70, 1940, pp 534-535., 551.

Dobbs, R.M. and I.A. Gilmour, Combustion of Coal in a Fluidized Bed Boiler, Department of Chemical Engineering, University of Canterbury, New Zealand, April., 1976.

Dolch, P., Die Verflüchtigung von Kileselsäure und Silizium als Silizium-Sulfid, Eine technologische Studie, Chem. Fabr., v 8, N 51, 52, 1935, pp 512-514.

Dolch, p., Verrgasung von Steinkohle im Fahrzeuggaserzeuger, Brennstoff chemie, v 17, n 4, 1936. pp. 67-69.

Dolch. p., Über die Verflüchtigung von Silizium and Kieselsäure firch Schwefel and ihre Bedeutung für die Praxis, Montan. Rundschau, v 27, n 1, 1935, pp. 3-4.

Dowson, J.E. and A.T. Larter, Producer Gas, Longmans Greeb and Company London, England,1907.

Dowson, J.E. and A.T. Larter, Producer Gas, Longmans Green and Co., London, 1907.

Dowson. J.E. and A.T. Larter, Producer Gas, Longmans Green andd co., Londen, 1907.

Dunstan , W .N. , Gas Engine and Gas Producer Practice in Australia, Engineer, v 180, n 4688, 1945, pp 400-401.

Edgecombe, L.J., The Determination of Potential Tar in Antracite and Fuels Containing Small Amounts of Tar, Fuel Science and Practice, v 19, n 9, 1940, pp 201-203.

Edmister, W.C . et al., Thermodybamics of Gasification of Coal with Oxygen and Steam, Transaction

of the American society of Mechanical Engineers, v 74, July 1952, pp. 621-636.

Egloff, G. and P. Van Arsdell , Motor Vehicles Propelled by Producer Gas, The Petroleum Engineer, v 15, n 4, 1944, pp 144, 146, 148, 150.

Egloff, G., and M. Alexander, Combustible Gases as substitute Motor Fuels., Petroleum Refiner, v 23, n 6 , 1944, pp 123-128.

Egloff. G., Fuels Used in sweden, petroleum Engineer, v 18, n 5, 1947, pp 86 -88.

Ekamn, E. and D. Asplund, A Review of Research of Peat Gasification in Finland, Technical Research Centre of Finland, Fuel and Lubricant Research Laboratory, Espoo, Finland.

Eke, P.W., Gas as an Engine Fuel, Transactions of the Institute of Marine Engineering, 1970, pp 121-138.

Ekman, E. and D. Asplund, A Review of Research of Peat Gasification in Finland, Technical Research Centre of Finland, Fuel and Lubricant Research Laboratory, 02150, Espoo 15 Finland , 1972.

Ekman, E.and D. Asplund, A Review of Reasearchof peat Gasification in Finland, Technical Reasearch Centre of Finland , Fuel and Lubricant Research Laboraartory, Espoo, Finland.

Enever, W.F., Gas Conditioning, Some Notes on Cleaning and Cooling Equipment , Automobile Engineer, v 33, n 436, 1943, pp 199-200.

Ergun, S., Kinetics of the Reaction of Carbon Dioxide with Carbon, The Journal of Physical Chemistry, v 60 , 1956, pp 480-485.

Feldman, H.F., al., Conversion of forest Residues to a Clean Gas for Fuel or Syntheisis, TAPPI Engineering Conference, New Orleans, Louisiana, November 26, 1976.

Forbes , W., Experiments with Gas Producer Vehicles in Cardiff, Passenger Transport Journal, November, 1939, pp 201-205

Foster- Wheeler Co., Air Gasification , Retrofit 79 Proceedings, The Solar Energy Research Institute, SERI/TP - 49 183, Seattle, Wash., February, 1979.

Foster Wheeler Energy Corporation, Gas from Coal: A Volatile Solution Energy Guidebook, 1978 , pp 108-110.

Fowke, W.H., Operating Results with Producer Gas, Bus and Coach, v 10, n 2, 1938, pp 84-86

Freeth, W.E., Producer Gas for Agricultural purposes, Jouranal of the Department of Agricultural of Western Australia, v 16, n 4, 1939, pp 371-414.

Funk, H.F. Treating Waste Material to produce Usable Gases, United States Patent, N 3970524, July 1976.

Gall. R.L., and J.D. Spencer. , Coal Behaviour in Gas- Producer Tests, Coal Age, v 71, Garret, D.E. Conversion of Biomass Materials into Gaseous Products, Thermochemical Coordination Meeting, Fuels from Biomass program, Energy Research and Development Administration, Columbus, Ohin, April. 1978.

- Giffen, E., et al., The Conversion of Compression-Ignition Engines to Producer- Gas Operation, Engineering, August, 1944, pp 98-159.
- Goldman, B. and N.C . Jones, The Modern Portable Gas Producer, The Petroleum world, v 36, n 460, 1939 pp 3-5.
- Goldman, B. and N.C. Jones, The Modern Portable Gas Producer, Institute of Fuel, v 12, n 63, 1939, pp 103-140.
- Goldman, B. and N.C. Jones, The Modern Portable Gas Producer, Institute of Fuel, London, v 12 , n 63, 1939, pp 103-140.
- Goldman, B, And N.C. Jones , The Modern Portable Gas Producer, The Engineer, v 166, December, 1938, pp 248-252.
- Goldman. B . and N.C. Jones, The Modern Portable Gas Producer, Institute of Fuel, London, V 12, N 63, 1939, pp 103-140.
- Goldman. B., Fuels Alternative to Oil for Road Transport Vehicles, Fuel Economist, V 14, July, 1938, pp 248-252 .
- Goldman. B. and N.C. Jones, The Modern Portable Gas Producer, Institute of Fuel, v 12, n 63, 1939, pp 103-140
- Goldstein , I., Wood Technology, Chemical Aspects, Am. Chem. soc., 172nd Meeting, San Francisco, August 31, 1976.
- Goring, G.E., et al., Kinetics of Carbon Gasification by Steam, Industrial and Engineering Chemistry, v 44, n 5, 1952, pp 1051-2591.
- Goring. G.E., et al., Kinetics of Carbon Gasification by Steam, Industrial and Engineering Chemistry, v 45, n 11, 1953, pp 2586-2591.
- Goss, J.R.m et al., Transient and Steady- State Temperature Fluctuation in a Downdraft Gas Producer, Meeting of American Society of Agricultural Engineers, Pacific Region, Hilo, Hawaii, March 1980.
- Goss, J.R., An Investigation of the Down- Draft Gasification Characteristics of Agricultural and Forestry Residues: Interim Report, California Energy Commision , p500-79-0017. November, 1979.
- Goss, J.R., et al., Transient and steady- state Temperature Fluctuation in a Downdraft Gas Producer, Meeting of American Society of Agricultural Engineers, Pacific Region, Hilo, Hawaii, March, 1980.
- Goss. J.R., An Investigation of the Down-Draft Gasification Characteristics of Agricultural and Forestry Residues: Interim Report, California Energy Commission, p 500-79-0017, Nov 1979.
- Greaves - Walker, A.F., The Design and Construction of a Producer-Gas House for Clay plants , Transaction of American Ceramic Society, v 18, 1916, p 862-866.
- Groeneveld, M.J. and K.R. Westerterp, Social and Economical Aspects of the Introduction of Gasification Technology in the Rural Areas in Developing Countries, American Chemical Society, Symposium on Thermal Conversion to Soild Wastes and Biomass, Washington, D.C., September, 1979.



- Groeneveld. M.J., The Co-Current Moving Bed Gasifier, Thesis, Technische Hogeschool, Twente, Netherlands, May 29, 1980.
- Gross, J.R., An Investigation of the Down- Draft Gasification Characteristics of Agricultural and Forestry Residues: Interim Report, California Energy Commission, p500-79-0017, November, 1979.
- Gumz, W., Gas Producer and Blast Furnaces, John Wiley and Sons, N.Y., 1950.
- Gumz, W., Vergasung Fester Brennstoffe, springer-verlag, Berlin, West Germany, 1952.
- Gumz, W., et al., Schlackenkunde, Springer-Verlag, Gottingen, 1958.
- Gumz. W., Gas Producer and Blast Furnace, John Wiley and Sons, New York, 1950.
- Harahap, f., et al., Survey and Preliminary Study on Rice Hull Utilization as an Energy Sources in Asian Member Countries, Development Technology Center, Institute of Technology , Bandung, Indonesia, March 1978, pp 193-236.
- Hartet-Seberick R., Motor Gas- Producers and Their Fuels, Their state of Development with Special Reference to the Use of Fossil Fuels, Fuel, London, v 16, n 1, 1937.
- Hawley, L.F., Wood Distillization, The Chemical Catalog Company, New York, 1923.
- Hendrickson, T.A. Synthetic Fuels Data Handbook, Cameron Engineers Inc. Denver, Colorado, 1975.
- Heywood, H., Loss of Power in Petrol Engines Running on Producer Gas, Engineering, January, 1941, pp 61-63.
- Holman, J.P., Thermodynamics, Third Edition, McGraw-Hill Company, New york, 1980.
- Holmann, A., Erdahrungen mit MAN Fahrzeug-Dieselmotoren im Dieselmotorgasbetrieb, Automobiltechnische Zeitschrift, v 44, n 8, 1941, pp 198-202.
- Howard, J.B., et al., Kinetics of Carbon Monoxide Oxidation in Postflame Gases, 14th Symposium on Combustion, Penn State Univ., August 1972, pp 975-986.
- Hurles, T.F. and A. Fitton, Producer Gas for Road Transport, Proceeding of the Institution of Mechanical Engineers, V 161 , 1949, pp 81-97.
- Hurley, T.F. and A. Fitton, Producer Gas for Road Transport , Proceedings of the Institution of Mechanical Engineers, v 161, 1949, pp 81-97.
- Hurley, T.F. and A. Ditton, Producer Gas for Road Transport, Proceedings of the Institution of Mechanical Engineers, v 161, 1449, pp 81-97 .
- Jankins,B.M. Downdraft Gasification Characteristics of Major California Residue- Derived Fuels, Ph.D. Thesis, Engineering University of California, Davis, 1980.
- Jenkins, B., Downdraft Gasification Characteristics of Major California Residue-Derived Fuels, Ph.D. Thesis, Department of Agricultural Engineering, University of California, Davis, 1980.
- Jenkins, B.M., Downdraft Gasification Characteristics of Major California Residue-Derived Fuels, Ph.D. Thesis in Engineering, Univ. of California, Davis, 1980.

Johnson, J.L., Kinetics of Bituminous Coal Char Gasification with Gases Containing Steam and Hydrogen , Symposium on Coal Gasification, Division of Fuel Chemistry, Meeting of A.C.S., Dallas, Texas, April 1973.

Jones, J.L. and S.B. Radding, Solid Wastes and Residues Conversion by Advanced Thermal Processes, American Chemical Society, Symposium Series, n 76, Washington, D.C., 1978.

Kaupp Albrecht, Gasification of Rice Hulls, Gate / Vieweg, Bonn, 1984

Kaupp Albrecht, Goss J, Small Scale Gas Producer-Engine Systems, Gate/Vieweg, Wiesbaden, 1984

Kaye, E. and A. Burstall, Gas Producers for Motor Vehicles, Institution of Engineers, Australia Journal, v 14 , n 4 , 1942, pp. 81-93.

Kennedy, W.B., Mixtures of Producer Gas and Petrol, Institute of Engineers, Australia, V 12, n 9, 1940, pp 259-263.

Knutson, J.etal., Crop Residues in California- Some Factors Affecting Utilization , University of California, Division of Agricultural Sciences, Leaflet 2872,1978.

Kralik, F. , Rail Car with Charcoal Gas Producer, The Engineer´s Digest, December, 1943, pp 24-25.

La rue, J. andG. Pratt, Problems of Compacting Straw, Sixth Annual Conference, Biomass Energy Institute, Winnipeg, Manitoba, Canada, October 13, 1977.

Lang, W.A., Alternative Fuels for Motor Vehicles, Engineering Journal, v 26, n 8, 1943, pp 449-454 .

Langley. F.D., The Revival of Suction Gas Producer , Gas and Oil power, v 37 , n 446 , 1942, pp 236-240.

Lees, B., Particle Size Distribution of the Dust in Producer Gas, Guel, London, v 28, n 9, 1949, pp 208-213.

Lees, B., Ammonia, Hydrogen Cyanide and Cyanogen in Producer Gas, Fuel, v 28, n 5, 1945, pp 103-108.

Levin, Ernest M. and Carl R. Robbins, Phase Diagrams for Ceramists, The American Ceramist Society, Columbus, Ohio, 1964.

Lindmark. G., Swedish Gas Producer Buses, Bus and Coach, April , 1944, pp 266-269.

Littlewood, K., Gasification: Theory and Application, Progress in Energy and Combustion Science, v 3 , n 1, 1977, pp 35-71.

Lustig. L., New Gas Producer for Dual Fuel Engines, Diesel progress, v 13, n 5, 1947, pp 42-43.

Lustig. L., New Gas Producer for Dual Fuel Engines, Diesel progress, v 13, n 5, 1947.

Marchello, J.M. and J.J. Jelly, Gas Cleaning for Air Quality Control, Marcel Dekker Inc. New York, 1975.

Marks, L.S. and S.S. Wyer, Gas and Oil Engines and Gas Producer, Chicago American School of Correspondence, 1908.

- Mellgren, S. and E. Anderson , Driving with Producer Gas, National Research Council of Canada, RP 15743, Ottawa, Canada, 1943.
- Mellgren, S. and E. Andersson, Driving with Producer Gas, National Research Council of Canada, RP 15/43, Ottawa, Canada, 1943.
- Meyer, W., The Supercharging of Internal Combustion Engine Plants Driven by Producer Wood Gas With Special Reference to Motor Vehicles, Brown Boveri Review, v 28, n 8, 1941, pp 206-208.
- Michalski, W. and J. Spers, Conversion of Compression Ignition Engines to Producer Gas Operation, Gas and Oil Power, v 39, n 468, 1944, pp 244-249.
- Middleton, F.A. and C.S. Bruce, , Engine Tests with Producer Gas Journal of Research of the National Bureau of Standards, v 36, February, 1946.
- Miller, R.H.P., Gasogens, U.S. Department of Agriculture, Forest Service, Forest Products Laboratory, Madison, Wisconsin, 1944.
- Mon, E. and N.R. Amundson, Diffusion and Reaction in a Stagnant Boundary Layer About a Carbon Particle, Part 2: An Extension, Ind. Eng. Chem. Fundam., v 17, n 4, 1978, pp. 313-321.
- Negretti, W., The Adaptation of Turbo-Charged Producer-Gas-Operated Engines to Vehicle Running Condition , The Brown Boveri Review, v 30, n 7, 8, July/August 1943, pp 184-187.
- Ngunlowo, A.S., Design Modification and Control for the Operation of a Single- Cylinder Air - Cooled Naturally-Aspirated Diesel Engine on Producer Gas Using Pilot Injection of Diesel Fuel, M.S. Thesis, Department of Agricultural Engineering, University of California, Davis, 1979.
- Overend, R., Wood Gasification: An Old Technology with a Future ? Sixth Annual Meeting, Biomass Energy Institute Symposium, Winnipeg, Manitoba, Canada, October, 12, 1977.
- Parker, H.W. and L.H. Holmes, Alternative Energy Sources of Agricultural Applications Including Gasification of Fibrous Residues, Texas, Energy Advisory Council, Energy Development Fund, 1979.
- Partridge, J.R., Manitoba Crops as an Energy Sources, Sixth Annual Conference Biomass Energy Institute, Winnipeg , Manitoba, Canada, October 12, 1977.
- Pavia, R.E., Woodgas Producers for Motor Vehicles, Institution of Engineers Journal, Australia, v 14, n 12 , 1942, pp 279-292.
- Payne, F.A., et al., Gasification-Combustion of Corncobs and Analysis of Exhaust, American Society of Agriculture Engineers Summer Meeting , San Antonio, Texas, paper #80-3025, 1980.
- Peart, R.M., et al., Gasification of Corn Cobs in a Producer Gas Generator, Third National Conference and Exhibition on Technology for Energy Conservation, Tucson, Arizona, January, 1979.
- Perry, Robert H. and Cecil Chilton, Chemical Engineers Handbook, McGraw Hill Company, New York, 1973.
- Porter, J.C. and R. Wiebe, Gasification of Agricultural Residues, U.S. Department of Agriculture, Northern Regional Research Laboratory, AIC-174, 1948.
- Rambush, N.E., Modern Gas Producers, Van Nostrand Company, New York, 1923.

Redding, G.J., The Effect of Fuel Moisture Content on the Quality of Gas Produced from the Gasification of Crop and Forest Residues, Master's Thesis, Department of Agriculture Engineering University of California, Davis, 1979.

Reed, T.B., A survey of Biomass Gasification, Volume 2, Principle of Gasification, Publication # SERI/TR-33-239, Solar Energy Research Institute, Golden, Colorado, 1979.

Reisner, W and M.V. Eisenhauf Rithe, Bins and Nunkers Company for Gandling Bulk Materials, Trans. Tech Publications, 1971.

Renton. C., Producer Gas Tests in the Queensland Railway Department, Institution of Engineers Journal , Australia, October, 1940, pp 274-278.

Ridley. C., Temporary Fuels, A Consideration of the Prospect of Their Permanency, Automobile Engineer, v 34, n 446, 1944, pp 63-67.

Roberts, R.P., Producer Gas Equipment on Tractors in Western Australia, Journal of the Department of Agriculture of Western Australia, v 15, n 4, pp 391-402.

Ruedy, R., Mechanical Troubles and Remedies in the Operation of Producer Gas Vehicles, National Research Council of Canada, RP 18/43, Ottawa Canada, September, 1943.

Ruedy, R., Sweden's Gas Producers, National Research Council of Canada, RP 16/43, Pttawa, Canada, September, 1943.

Ruedy, R., Wood and Charcoal as Fuel Vehicles, National Research Council of Canada, n 1157, Ottawa, Canada, 1944.

Schlapfer, P. and J. Tobler, Theoretische und Praktische Untersuchungen Über den Betrieb von Motorfahrzeugen mit Holzgas, Schweizerische Gesellschaft für das studium der Motobrennstoffe, Bern Switzerland, 1937.

Selvig, W.A. and D.H. Gibson, Analysis of Ashfrom United States Coals, U.S. Department of Interior , Bureau of Mines, Bulletin 567,1956.

Shafizadeh , F., et al., Thermal Uses and Properties of Cagbohydrate and Lognins, Academic press, New York 1976.

Spiers, H.M., Technical Data on Fuels , Sixth Edition, British National Committee of the World power Conference, London , 1961.

Spiers, J. And E. Giffeb, Producer Gas: The Effect of Compression Ratio on Performance, Automobile Engineer, v 32, n 431, 1942, pp 523-527.

Srauss, W., Industrial Gas Cleaning, Pergammon press, New York, 1975.

Stairmand, G.J. and R.N. Kelsey, Chemistry and Industry, 1955, pp 1324.

Stern, A.C., Air Pollution, Academic press, New York, 1974.

Takada, S. and J. Sakai, Research on Gas Engine Driven by Agricultural Waste, The Bulletin of the Faculty of Agriculture, Mie University, Tsu, Japan, N 53, 1976, PP. 187-203.

- Takeda, S., Research on Gas Engine 2, Annual of Institute of Tractor Research and Testing, n 3, 1979, pp 19-36.
- Takeda, S., Development of Gas Engine (I) , The Bulletin of the Faculty of Agriculture, Mie University, Tsu, Japan, N 58, 1979, pp 137-141.
- Takeda, S., Research on Gas Engine (II) , Annual of Institute of Tracter Research and Testing, Mie University, Tsu, Japan, N 3 , 1979, pp 19-36.
- Takeda, S., Development of the Gas Engine , The Bulletin of the Faculty of Agriculture, Mie University, Tsu, Japan, n 58 , 1979, pp. 137.141.
- Takeda, S., Development of Gas engine, The Bulletin of the Faculty of Agriculture, Mie University, Tsu, Japan, N 58, 1979, pp.137-141.
- Tatom, J.W. Survey of International Biomass Gasification Equipment, Solar Energy Research Institute, Goldan, Colorado, Contract AD-8-1187-1, September, 1978.
- Taylor, C.F., The Internal Combustion Engine in Theory and Practice, Volume I, The Massachusetts Institute of Technology Press, Cambridge, Massachusetts, 1977.
- Taylor, G., Gas Generators Capture European Interest, Automotive Industries, V 82, n 1, 1940, pp 22-25.
- Taylor. G., Gas Generators Capture European Interest, Automotive Industries, v 82, n 1. 1940, PP 22-25.
- Telford, W.M., Some Notes on the Design of Mobile Producer Gas Units Gas and Oil Power, v 36, September, 1941, pp 179-181.
- Telford. W.M., Some Notes on the Design of Mobile Producer Gas Units, Gas and Oil Power, v 36 , September, 1941, pp 179-181.
- Tookey, W.A., Suction Gas Plant Development Fifty years Ago, Engineer, v 193, n 5028, 1952, p 754.
- Treybal, Robert, Mass-Transfer Operation, McGraw-Hill Co., New York, 1980.
- Tsoumis, G., Wood as Raw Material, Pergammon Press, New York, 1968.
- Twelvetrees, R., Paving the Way for Producer Gas Operation , Bus and Coach, May, 1943, pp 104-107.
- U.S. Department of Health, Education and Welfare, Control Techniques for Air Pollutants, Washington, D.C., 1969, pp 4-172.
- Walton, J., Alternative Fuels, Automobile Engineering, v 30, March, 1940, pp 91-92.
- Wen, C.Y. and J. Huebler, Kinetic study of Coal Char Hydrogasification Rapid Initial Reaction, Industrial and Engineering Chemistry process Design and Development, v 4, n 2, 1965, pp 142-147.
- Wen, C.Y. and J. Huebler, Kinetic study of Coal Char Hydrogasification Rapid Initial Reaction, Industrial and Engineering Chemistry process Design and Development, v 4, n 2, 1965, 147-154.

Wenzl, H.F.J., The Chemical Technology of wood, Academic Press, New York, 1970.

Williams, R.O. And B. Horsfield, Generation of Low-BTU Gas From Agricultural Residues, Experiments with a Laboratory- scale Gas Producer, Proceedings of Cornell Agricultural Waste Management Conference, New York State Collage of Agriculture and Life , 1977.

Winden John, Repair and Maintenance of Stationary Diesel Engines, Tool, 1990

Wise, L.E., Wood Chemistry, Reinhold Publishing Corporation, New York, 1944.

Woods , M.W., Producer Gas Vehicles, Institution of Engineers Journal Australia, v 10 , n 3 , 1938 , pp. 89-96.

Woods, M.W., An Investigation of the High-Speed Producer Gas Engine, Engineer, v169, n 4401, 1940, pp 448-450.

Wyer, S.S., A Treatise on Producer Gas and Gas Producers, Hill Publishing Company, 1906.

Zielke, C.W. and E. Gorin, Kinetics of Carbon Gasification , Industrial and Engineering Chemistry, v 47, n 4 , 1955, pp 820-825.

Zielke, C.W. and E. Gorin, Kinetics of Carbon Gasification , Industrial and Engineering Chemistry, v 9, n 3, 1957, pp 396-403.

[View this page in text format](#)