

17/12/70.

Mr Ron Carroll;
P.O. Box. 160.
Cary;
North Carolina;
27511.
U.S.A.

Harold Bate;
Penny Rowden;
Blackawton;
Totnes. Devon.
England. T Q 9. 7 D N.

Dear Mr Carroll;

Please find enclosed -

1. Gas Converter Device.
1. Gas Jet for carburetter; Extra Jets - 1. Dollar each.
1. Set of Instructions and Drawings (Gas Device)
1. Set of Instructions and Drawings (Methane Gas Production)

Yours Sincerely;
Harold Bate.

H. Bate

Methane Gas Production

By HAROLD BATE

Methane Gas when mixed with ten times its volume of air or twice its volume of Oxygen when ignited constitutes a mixture which is highly expansive forming Carbon Dioxide and water vapour, and when used as a fuel to drive an internal combustion engine Methane Gas contains more useful power and a much higher efficiency than Diesel or Petroleum fuels. In many coal mines methane is present and mixed with air is known as fire damp. Methane Gas is also produced from all kinds of decaying vegetable and animal matter, leaves, grass, straw, weeds, etc. Nearly pure Methane Gas is composed of:—

Methane	89.61
Nitrogen	9.61
Carbon Dioxide	0.23
Oxygen	0.55

Calorific value B.T.U. per lb. :—

Methane	22,000
Petrol	19,000
Propane	19,944
Butane	19,680

For quick production with large volume, farmyard manure, especially pig and fowl manure are recommended. The contents of the domestic septic tank are also suitable.

METHANE GAS PRODUCTION FROM MANURE AND WASTE MATTER

The preparation of farmyard manures and waste matter for the formation of Gas is done in two stages. The first stage is aerobic prefermentation. This is usually caused by making a compost pile of manure—chopped straw—and any other vegetable waste. The pile is dowsed with water and left for about a week exposed to the air. During this period, urine is broken down to Ammonium Carbonate and intake of Oxygen. Some of the complex sugars and starches are broken down and the formation of Butric Acid which is believed to be inimical to the growth of the Methane producing organism in the latter Anaerobic stage of the process is prevented.

Stage two: When the prefermentation is complete, the material is placed in an air tight container called a DIGESTER where under suitable temperature conditions Anaerobic fermentation takes place. At first, the Gas contains little or no Methane and may consist of almost—almost entirely—of Carbon Dioxide. Small quantities of Hydrogen Sulphide and Ammonia may also be present. After a week or so—depending on conditions—Gas rich in Methane is evolved in useful quantities. The Digester will still continue to produce Gas for several weeks but this will gradually become reduced. If the manure and waste matter instead of being formed into a compost heap on the ground—it is placed directly into a Digester and air is bubbled through the Digest, none of the liquid contents are lost and prefermentation will take place more quickly. The Gas is collected in a Gas Holder and used as required.

When an industrial waste as against farm manure is very concentrated containing 1% or more of solids as in the case of distilling, dairy, packing house and other wastes, Methane fermentation offers an attractive method of treatment. Many types of organic matter can be used to produce Methane Gas but a good mixture is pig manure, straw and poultry manure. Manure to provide the Nitrogen, ; straw and/or vegetable waste to form Carbon. Half pig manure mixed with chopped bedding straw and half poultry or cattle manure or slurry forms a good mixture.

1 cwt. of manure=500 cu. ft. of gas or more.

METHANE GAS PRODUCERS

One of the simplest types of Methane Gas producers consists of a pit dug in the ground and lined with brick or concrete; or a tank built on to a low stilage above ground. A useful size would measure approx. 10 ft. diameter by 10 ft. deep, or 10 ft. square. The Gas Holder can be the same size or larger. Whatever container is used the cover must be air tight when placed in position.

Where the sewage from a domestic dwelling drains into a septic tank, the tank forms a ready made Methane Gas Producer. To prepare the septic tank for the production of Methane Gas, a non return flap valve is fixed on to the sewer pipe where it enters the tank. This is to stop the gas escaping by way of the sewer pipe, as shown on the drawing. Next, the septic tank vent pipe is drilled and a gas tap fitted. Any other opening in the vent is sealed up. A hole is then made in the tank cover and a thermostatic electric immersion heater is fitted in the same manner as it would be in a domestic water heating system. The length of the heater should be the longest obtainable so that it will go well down into the digest. The thermostat should be set so that it gives a steady heat of 85 deg. Fah. to 90 deg. Fah. Another small hole is made in the cover to enable a thermometer to be inserted into the digest now and then to check the temperature. This hole must be fitted with a gas tight stopper. If the tank is built above ground on a low stilage, the digest can be heated by a gas ring, and as soon as the gas is generated the ring can be connected to the producer gas holder. The production of gas will then be automatic. Another cheap method of applying heat to a septic tank is to run a steam pipe through the contents and connect it to the domestic hot water supply.

The whole secret of the production of Methane Gas lies mostly in the maintenance of the digest at a temperature of 85 deg. Fah. to 90 deg. Fah. If the temperature rises above 104 deg. Fah. the bacterial digestion of the contents of the gas producer will cease and gas will not be produced. A good average temperature lies between 84 deg. Fah. to 88 deg. Fah. In hot climates no artificial heating is required, especially in Africa and India. In most parts of these countries the heat from the sun is quite sufficient for the efficient running of the Methane Gas Producer.

COMPRESSING GAS INTO HIGH PRESSURE GAS BOTTLES

A suitable High Pressure Compressor for filling Gas Bottles is shown on the drawings. This is the type used for filling aqualung diving bottles. Gas bottles should be under water while filling. Gas outlet on compressor must be fitted with a good filter and pressure gauge reading to 3,000 per square inch.

It must be understood that the author of the information detailed in these papers cannot be held responsible for any accidental damage to persons or property arising from the construction or use of the apparatus described.

HAROLD BATE

PENNY ROWDEN, BLACKAWTON, TOTNES, DEVON, ENGLAND

Suitable compressors, high pressure ex-W.D. gas bottles and fittings can be obtained at reasonable prices from Messrs. B. Pryce, 157 Malden Road, Cheam, Surrey.

Immersion heaters, thermostats and various fittings from Messrs. Proops Bros. Ltd., 52 Tottenham Court Road, London, W.1.

High pressure air gauges from L. Veysey and Machinery Mart, Mill Street, Crediton, Devon.

Compressors and high pressure air bottles can also be obtained from C. W. Wheelhouse, 11-13 Bell Road, Hounslow, Middlesex.

* Note.

Gas Digester should be replenished with fresh manure when Gas take off has become too low - about once per week.
About $\frac{1}{4}$ Of the digest should be left in Digester as this will seed the incoming fresh manure and cause Gas to be produced much quicker.

For Dry Manure - add 2 gallons of water to 1. cwt of manure.

Equipping a Petrol Engined Vehicle to run on Gas or Petrol

By HAROLD BATE

Penny Rowden; Blackawton; Totnes. Devon. England. T Q 9. 7 D N.

For the scheme to be a success, it must be safe, require very little alteration to the standard equipment of the vehicle, require no extra driving controls and to be automatic in operation. This has been achieved by fitting a special jet to the standard carburettor and connecting this jet to a suction operated vacuum valve.

The valve automatically supplies the gas according to the demand of the engine; once set, the mixture of air and gas is automatic. A pull-on push-off motor cycle type petrol tap is fitted between the carburettor and the fuel pump; this tap can be operated from the dashboard of a car by fitting an extension rod, enabling the petrol supply to be turned off when changing over to gas with the vehicle in motion. ON NO ACCOUNT SHOULD THIS TAP BE FITTED BETWEEN THE FUEL PUMP AND THE PETROL TANK AS THIS WOULD CAUSE DAMAGE TO THE FUEL PUMP. If the fuel pump is electric, it will only be necessary to connect a switch in the battery supply wire; the wires can be extended to the dashboard so that the pump can be switched on or off with the vehicle in motion.

CONNECTING UP AND STARTING THE ENGINE

There must be a clear passage through the pipe-line from the gas container to the vacuum valve; no restrictions, i.e.: regulating valve, non-return valve or filters, as these would cause freezing and are not necessary as no flash-back can occur through the vacuum valve. The outlet end of the valve is connected by approx. 12" of Calor Gas Rubber Tubing to the gas jet in the carburettor; the inlet end of the valve is connected by rubber or copper tube via the on/off gas tap to the gas container. The vacuum valve must not be connected directly to the gas container or it will freeze. To start the engine on gas, drain the carburettor and turn off the petrol, turn on the gas and ~~adjust the valve by the 2 B.A. nut on top of the compression spring so that the gas can just be heard escaping into the carburettor; this adjustment will give a slow tick-over and will assure instant starting on the coldest morning;~~ set the air strangler on the carburettor approx. $\frac{1}{4}$ open and press the starter. It is essential that the carburettor is fitted with a variable air strangler—usually a butterfly type at the air intake; if it is not, one can be fitted by drilling a $\frac{1}{4}$ " hole through each side of the carburettor near the air intake end and fitting a $\frac{1}{4}$ " brass spindle with a metal disc screwed to the centre of the spindle; the metal disc should be approx. the diameter of the carburettor intake; this will enable the air supply to be controlled as this is a very important part of the set-up, as when the engine is running on gas a considerable amount of air is drawn in through the petrol jets in the carburettor. A suitable position will be found in which to set the air strangler so that the engine answers to all positions of the throttle; the air strangler will then not need altering while running or starting on gas. For engines

* or start
on Petrol
& switch
over to
Gas.

* Note.

Vacuum Valve should be adjusted to cut-off Gas when engine stops.
For Propane Gas - steel or copper tubing $\frac{1}{2}$ " or $\frac{3}{16}$ " bore should be used
between Gas Container and Gas tap on car.
If flexible tubing is used from Gas tap to Vacuum Valve - this should be
High Pressure type.

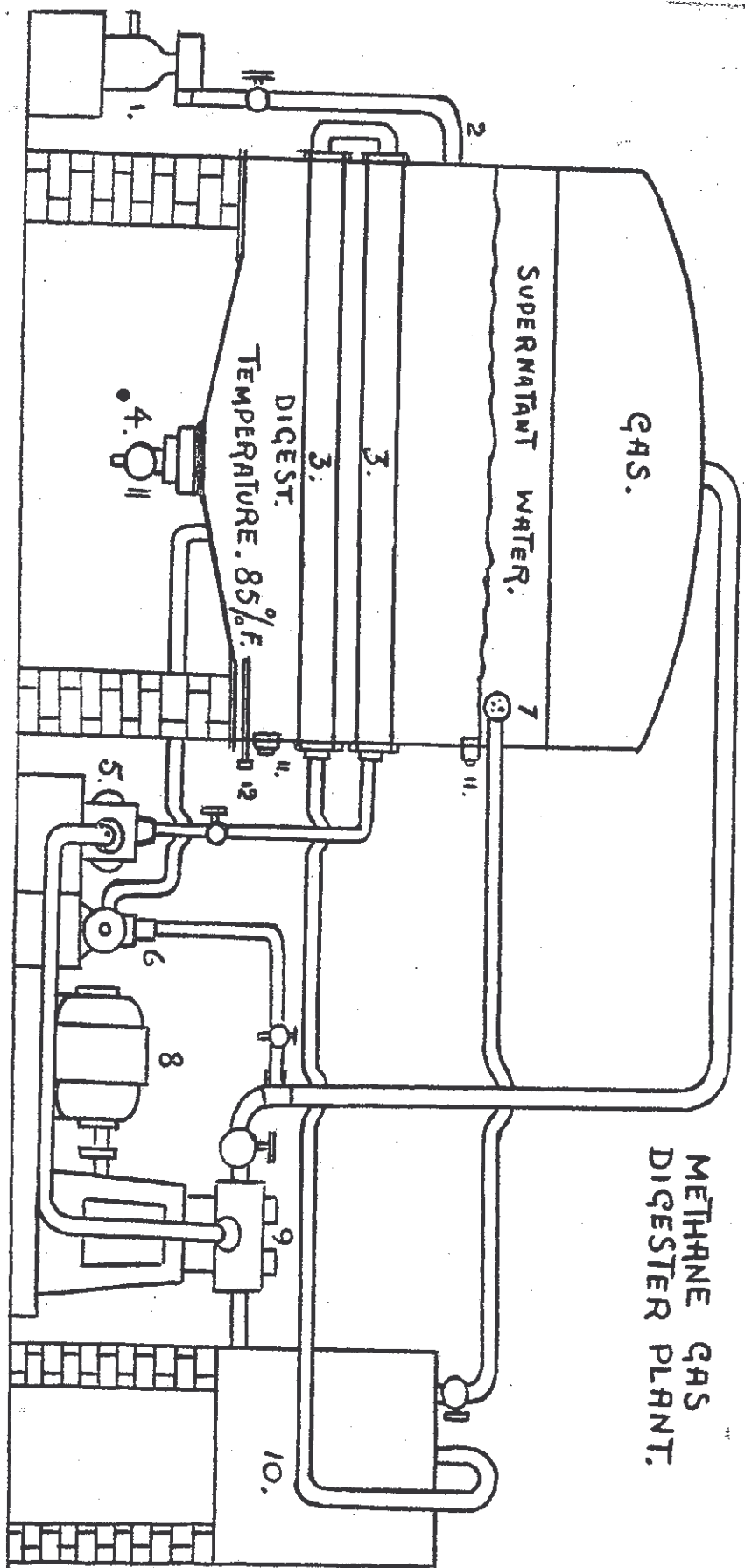

METHANE GAS
DIGESTER PLANT.

1. Slurry or Sludge Pump.
2. Digester tank. (30. tons manure weekly)
3. Heater Coil.
4. Sludge outlet.
5. Heater Coil circulating Pump.
6. Gas recirculating Pump. (for breaking up scum.)
7. Supernatant water run off.
8. Electric Generator.
9. Engine.
10. Hot water Tank; Can be heated independently by Gas when engine is not running.
11. Digest level inspection Plugs.
12. Thermometer.

DIGESTER TANK SIZES.

20,000. Birds--Tank	12ft. dia.	X 10ft.
12,000. "	"	X 8.
6,000. "	"	X 6.
3,000. "	"	X 4.

Pipes & Digester Heater Tubes - Size -
 1. inch. B.S.P. upwards according to size of
 Digester tank.
 Slurry or sludge Entrance Pipe -
 4. inch upwards.

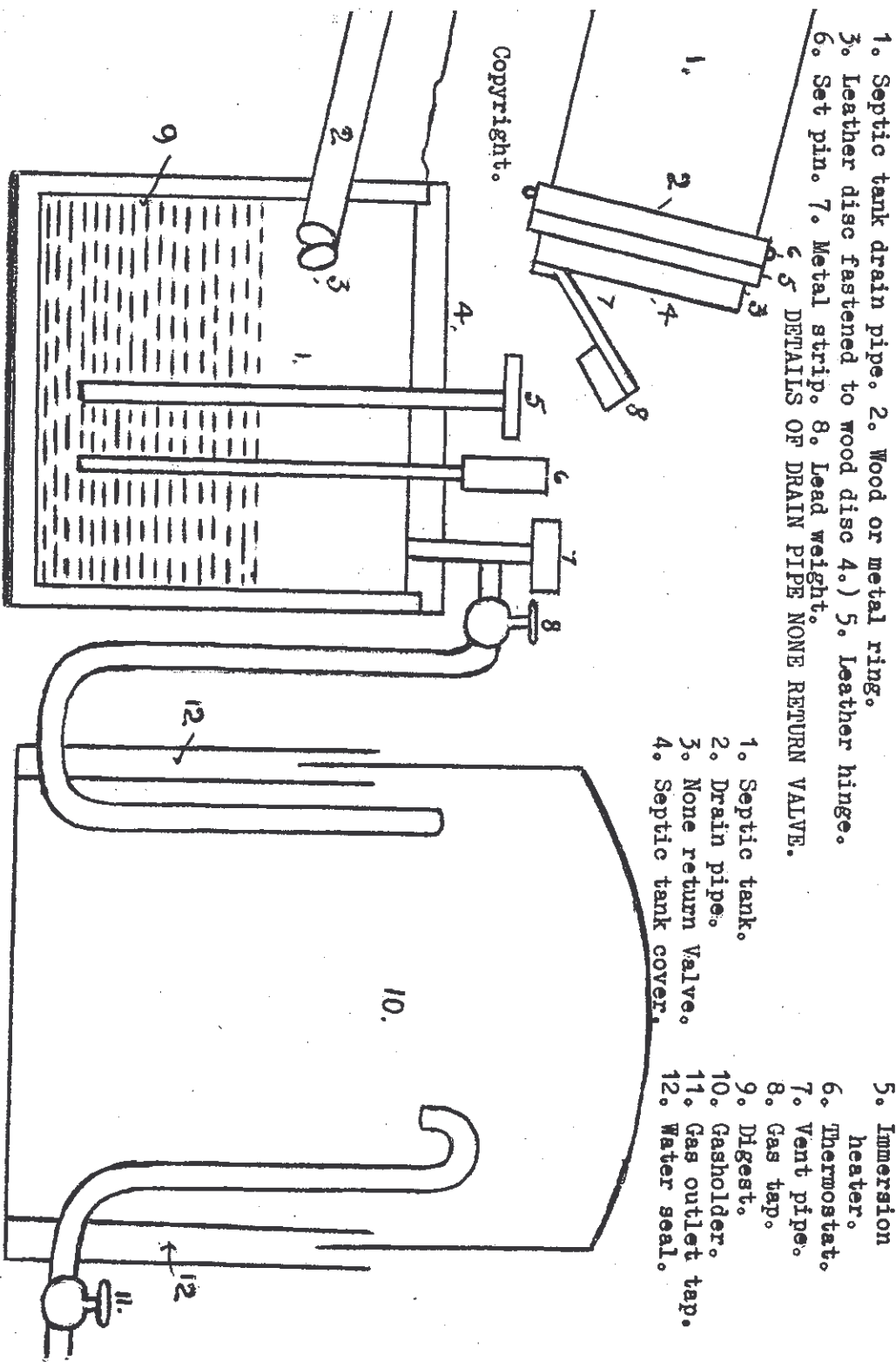

- 1. Septic tank drain pipe.
- 2. Wood or metal ring.
- 3. Leather disc fastened to wood disc 4.)
- 5. Leather hinge.
- 6. Set pin.
- 7. Metal strip.
- 8. Lead weight.

- 1. Septic tank.
- 2. Drain pipes.
- 3. None return Valve.
- 4. Septic tank cover.
- 5. Immersion heater.
- 6. Thermostat.
- 7. Vent pipes.
- 8. Gas tap.
- 9. Digest.
- 10. Gasholder.
- 11. Gas outlet tap.
- 12. Water seal.

Copyright.

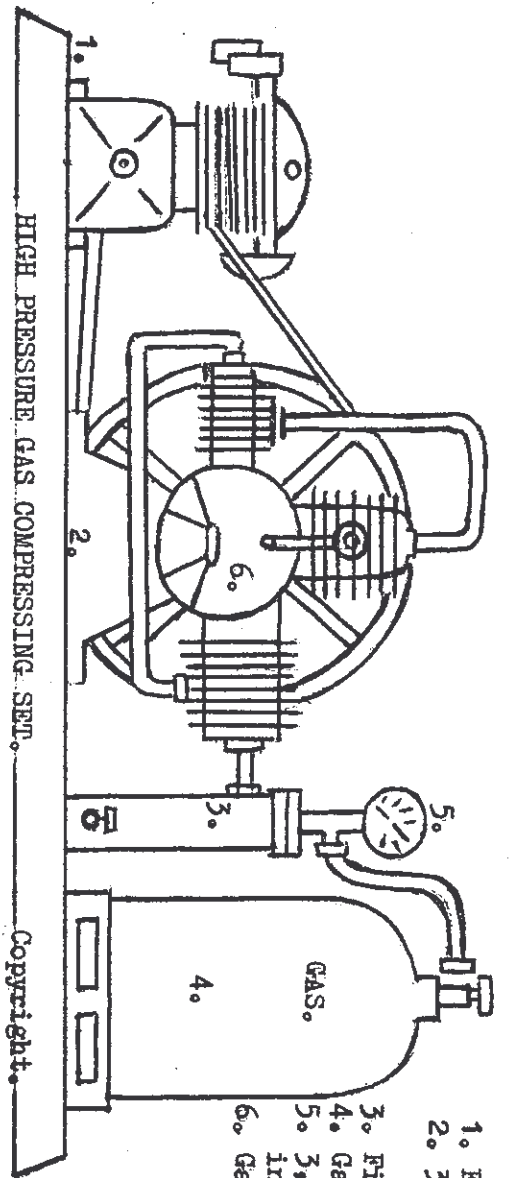

HIGH PRESSURE GAS COMPRESSING SET.

Copyright.

1. Engine - 2½ H.P.
2. 3 stage compressor.
(2,500lb.P.S.I.)
3. Filter.
4. Gas bottle.
5. 3,000 lb. per sq
inch Gauge.
6. Gas intake.

PORTABLE METHANE GAS PRODUCER SUITABLE FOR MOTOR VEHICLES.

1. Radiator.
2. Hot water supply pipe.
3. Hot water heater ring.
4. Hot water return pipe.
5. Hot water supply regulator tap.
6. Combined Digester - Gasholder.
7. Water seal.
8. Engine.
9. Gas outlet tap.
10. Thermometer, 11. Capillary tube.

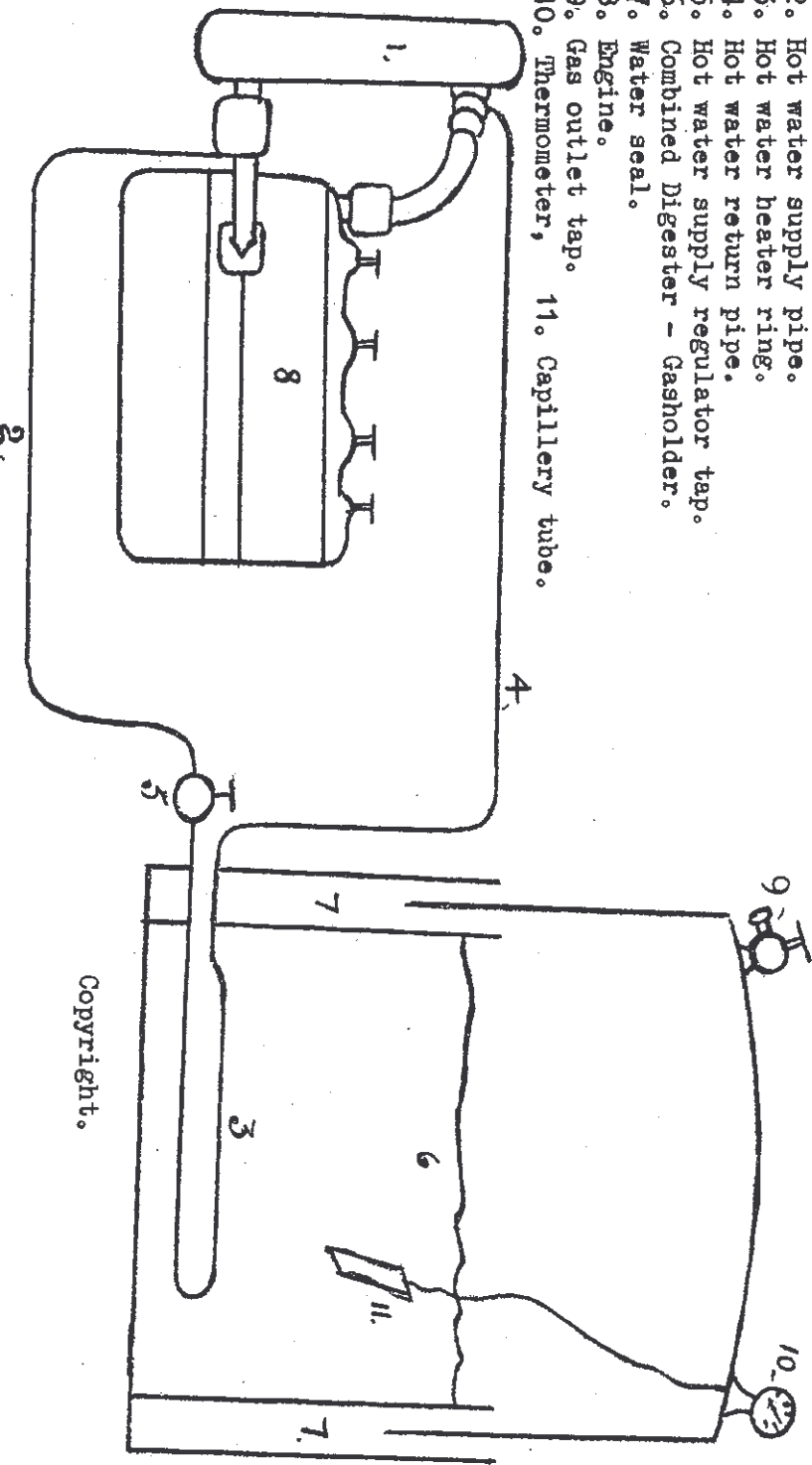

Copyright.

