

Build Your Own Turgo Powerplant

Use the spreadsheet below to determine the power potential of your site.

Click on pictures to enlarge

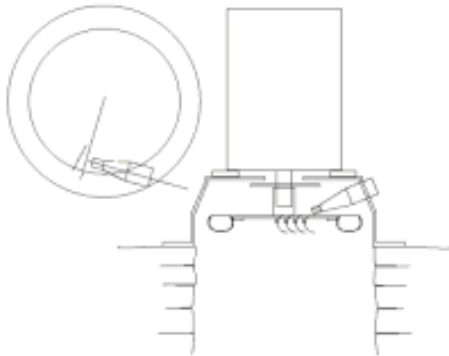

Schematic of a direct drive turgo system
Courtesy [Peter Ruyter](#) .



Find the runner diameter to match site head and rpm.



Motor, runner and nozzles on a simple welded and anodized aluminum frame.



Nozzles retracted to show runner, arbor and coupling arrangement for connection to motor shaft.

Tour the [Aspen Hollow Hydro Site](#)

Downloads

Sketch of [frame with shaft water seal](#) and [splash walls](#)

Pelton and turgo sizing spreadsheet [turgo.xls](#)

Momentum Balance model spreadsheet [impulse.xls](#)

Coupled Pipe Friction Loss & Turbine Spreadsheet [pipedp.xls](#) (uses macros)

Hub Drawings: [20, 24, and 26 Blue Spoon](#) , [30 Orange Spoon](#)

A handy [land and water conversion chart](#) produced by [Smith-Hartvigsen PLLC](#), a Salt Lake City based law firm specializing in water and natural resource law.



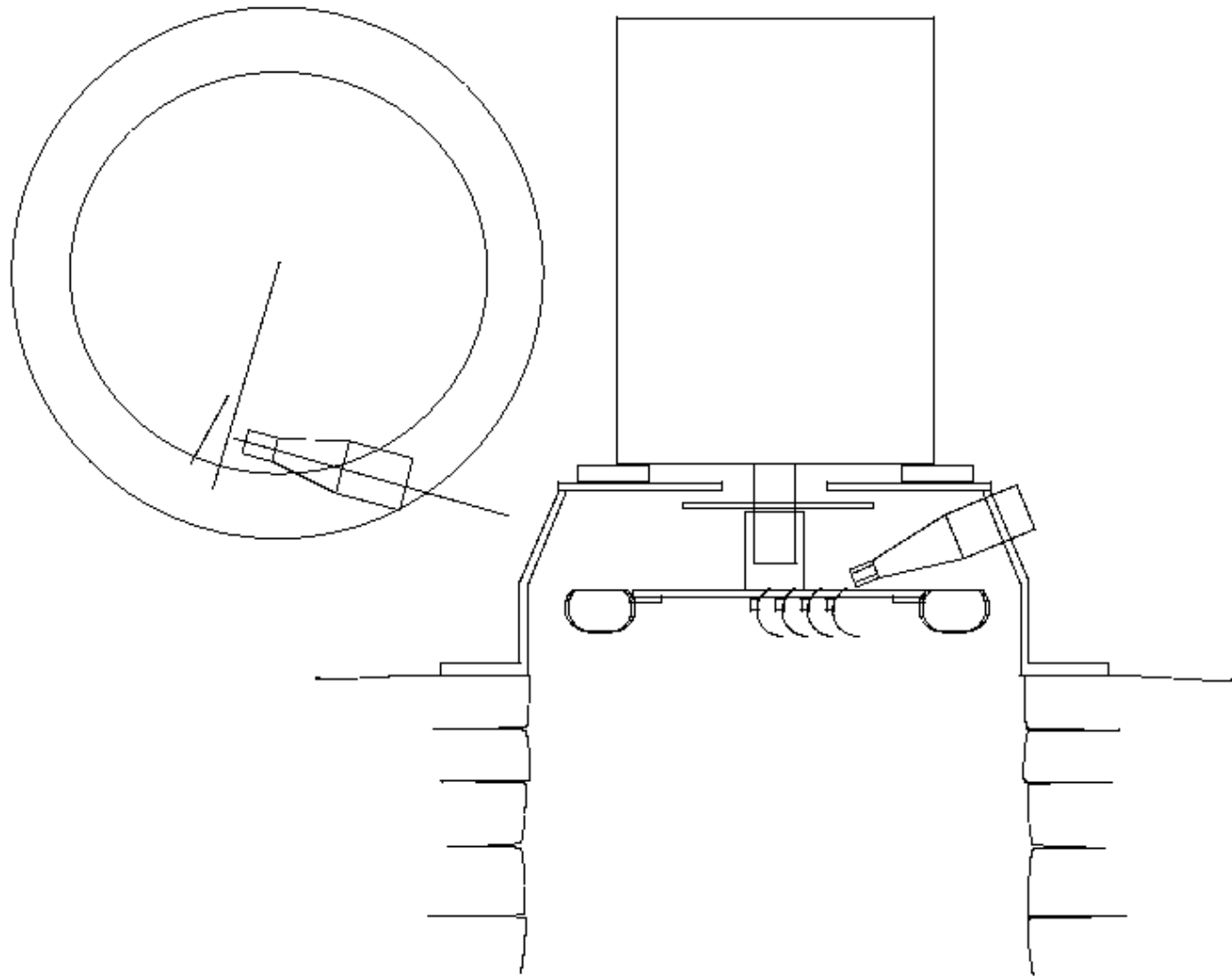





Aspen Hollow Micro-Hydro System Tour

Click on pictures for larger image



Intake Structure

The intake is a 20' (6 m) length of 18" (45 cm) diameter pipe with hundreds of 0.5" (12 mm) holes drilled in it. It was put in a trench parallel to the stream and covered with rock. This way we did not need to excavate or pour concrete in the stream bed. When we were ready for water, a few shovel strokes (human powered) let water run over the intake and back into the natural stream bed again. We then continue with a few lengths of 8" (20 cm) pipe and an air vent riser before going to 6" (15 cm) for the rest of the run. The pipe has "floated" up out of the ground a bit over the years because holes were not drilled in lower half of the pipe

perimeter. This picture was taken in late November after two of the driest years ever. Once I put a smaller nozzle in at the turbine, the water filled up the lower part of the picture and ran to the right back into the stream.

Pipeline Route

The pipe was buried in a trench about 4 feet deep most places. Near the top of the highlighted route it was much deeper to maintain grade. The pipe and installation cost are the largest part of the total cost of a microhydro system. We hired someone with a backhoe to dig the trench, but the pipe was installed by family and back filled using our dozer. The lower section of pipe shown in the second picture crosses the stream underneath an existing culvert. The intake is about 60 yards (meters) beyond where you can see in the upper section. The turbine is just over a 100 yards downstream of the edge of the picture below.





Turbine Blockhouse



A small shelter for the turbine and piping was build from concrete block. The wet end (with the horizontal shaft turbine configuration used the first 3 years) of the block started to crumble from freeze thaw damage so a concrete jacket was poured around part of the structure to stabilize it. The capacitor bank and circuit breakers to the capacitor bank are seen on the near side. Only 3 of the capacitors are used. I have a collection of various sizes which were used to find the optimum configuration. I found better results when I used lower values of μF in an attempt to hit a target frequency which matched the turgo peak power rpm, than trying to add more μF in an attempt to get the voltage up where I thought it should be. The transmission line wire is suspended as it crosses the stream, then is buried the 800' or so to the battery bank located in the "radar shack". The outflow (tailrace) and drain valve are shown in the picture below.



Turbine and Nozzle Piping

The foundation and floor of the blockhouse was poured with 2 cubic yards (2 m³) of concrete as a thrust block for the end of the pipeline. The motor-generator used in the original horizontal shaft system with an ES&D pelton was mounted on a concrete block pedestal in the blockhouse. When I put in the [new vertical shaft turgo](#) I was unable to chip out all of the mortar under the pedestal. If the blockhouse had been built a couple of feet larger, especially in the width, it would be much easier to work inside. Now it is a very tight squeeze to get in and change a nozzle. A larger space would have allowed the nozzles to be 180 degrees apart on the runner instead of 90 degrees, reducing bearing loads by symmetric loading.





Radar Shack

A surplus military truck body purchased about 30 years ago houses a LPG fueled generator, battery bank, inverter, hydro battery charging equipment and miscellaneous farm junk. The small side door on the lower left of the radar shack provides the access to the battery bank compartment. An 800 W solar array on the hill above was added this summer to help out when water is low. The combination of PV and hydro is nice, though the PV cost more than the hydro, and puts out much less power on a 24 hour basis (assuming good water flow is available). Inside the radar shack (below) you can see the Trace inverter, and mounted on the wall my hydro dump loads, 3 1kVA transformers, and a heat sink with a 3 phase 100A bridge rectifier.





Farm House



Installation of this system was motivated by the need to provide power when this house was build a few years ago. The power company charges about \$5/foot to bring in power, and it is over 5 miles to the nearest power lines. This project cost less than a tenth of what it would cost to bring in power lines, and there is no monthly power bill. For me it has been a fun challenge, that my wife might say has become an obsession. A more detailed write up (without pictures) was posted to the microhydro egroup site a few years ago. It is copied [here](#) , though some of the links in this page may not resolve correctly from this site.

Watermark Background

The distracting background watermark is a composite of an aerial photo of the farm found online, and pictures of a pair of my turgo runners.

[Return to the Hartvigsen-Hydro Home Page](#)

Hartvigsen-Hydro

Components for microhydro systems

Hartvigsen-Hydro
Joseph Hartvigsen
1529 South 400 East
Kaysville, UT 84037 USA
joe@h-hydro.com



Gladly accepted for your purchases

Custom Turgo Runners Sized for your site.

Use these tables to pick from 36+ different runners.
(match runner diameter, site head, spoon material and target rpm)
[spreadsheet file](#) or [pdf file](#)

Click on image for larger picture



Injection molded plastic bluespoons for use with nozzles up to 1 1/16" (17mm) bore.

- \$120 3.24" (82 mm) pitch diameter 20 bluespoon runner.
Assembled runner **includes basic arbor**, hub and 20 blue spoons
- \$150 3.69" (94 mm) pitch diameter 24 bluespoon runner.
Assembled runner **includes choice of custom or basic arbor**, hub and 24 blue spoons
- \$160 3.91" (99 mm) pitch diameter 26 bluespoon runner.
Assembled runner **includes choice of custom or basic arbor**, hub and 26 blue spoons



Precision cast stainless bluespoon size

- \$240 3.24" (82 mm) pitch diameter 18 cast **stainless** runner.
Assembled runner **includes choice of custom or basic arbor**, hub and 18 stainless spoons.
- \$300 3.69" (94 mm) pitch diameter 22 cast **stainless** runner.
Assembled runner **includes choice of custom or basic arbor**, hub and 22 stainless spoons.
- \$320 3.91" (99 mm) pitch diameter 24 cast **stainless** runner.
Assembled runner **includes choice of custom or basic arbor**, hub and 24 stainless spoons.



Injection molded plastic & cast stainless orangespoons for nozzles to 1-3/8" (34 mm) bore.

- \$240 Custom orangespoon runners for use with nozzles up to 1-3/8" (34mm) diameter. Assembled runner **includes choice of custom or basic arbor**, stainless hub and from 16 to 24 orange spoons (5.9-7.8" or 149-198mm pitch diameter)
Pitch Diameter: $D_p = \text{spoons} * 0.242" + 2"$ or $D_p = \text{spoons} * 6.15 \text{ mm} + 51 \text{ mm}$
Runners with more than 24 spoons are available at a cost of \$10*spoon count.
Custom center hole and mounting bolt circle for your shaft flange available with no extra charge.
- \$480 Custom runners using a **precision cast stainless steel orange spoon replica**. Price shown for runners from 16 to 24 spoon. Runners with more than 24 spoons are available at a cost of \$20 per spoon. Runner pitch diameter matches orange spoon runners.
- \$720 Custom runners using a **precision cast stainless steel 150% scale replica of orange spoons** . Price shown for runners from 16 to **NEW** 24 spoon. Runners with more than 24 spoons are available at a cost of \$30 per spoon. Runner pitch diameter is 1.5 x orange spoon runners.

Turgo Spoons: Build your own turgo runner.



Click on photo for larger image

Hub [drawings or templates](#) available.

- \$3 Blue spoons to build your own runner. Made in Sweden.
Turgo spoons for use with nozzles up to 11/16" (17mm) diameter.
- \$4 Orange spoons to build your own runner. Made in Sweden.
Turgo spoons for use with nozzles up to 1-3/8" (34mm) diameter.
- \$12 Precision cast stainless steel replica of the bluespoon.
Turgo spoons for use with nozzles up to 11/16" (17mm) diameter.
- \$16 Precision cast stainless steel replica of the Orange spoon.
Turgo spoons for use with nozzles up to 1-3/8" (34mm) diameter.
- \$24 Precision cast stainless steel 150% scale replica of the Orange spoon.
NEW Turgo spoons for use with nozzles to 2.0 inch (50 mm).

Nozzles



Standard nozzle sizes and flow rate [table \(.pdf\)](#) or [spreadsheet \(.xls\)](#).
Information on [nozzle alignment](#) for turgo runners

\$9 Series 70 (3/8" NPT) nozzles.

\$18 Series 80 (3/4" NPT) nozzles.

\$60 Series 125 (1-1/4" NPT) nozzles, custom machined brass in 3/4", 7/8", 1", or 1-1/8" bore.

Turgo and Pelton Arbors



\$15 Basic arbor to fit motor/generator shaft and mount 1/2" ID impulse runner. Shaft sizes 3/8", 1/2", 5/8", and 5/8" with keyway. Will also fit ES&D pelton. Specify RH or LH thread. Use LH thread with turgo spoons above to direct water away from generator. Pelton may use either.

\$25 Custom arbor to fit 7/8", 1-1/8" keyed shaft (shaft coupling required), or threaded to fit most Ford or GM alternators. Specify RH or LH thread for arbor shaft (1/2-20RH or 1/2-20LH).

\$25 Shaft coupling for 7/8" or 1-1/8" arbors.

Technical Information

[Example Turgo System, Spreadsheets & Drawings](#)

[Photo Tour of My Microhydro Site](#)

Ordering Information

Shipping:

\$6 USA, \$15-\$20 International for spoons & blue runners

\$15 USA, \$25-\$35 International for orange spoon runners

I now offer inverters, PV, wind turbines, controllers, etc. to complete your system



[Through ProPay.com](http://ProPay.com)

or use your PayPal.com account (by eBay)

[Ordering and ProPay Instructions](#)

Para informacion y venta en España [contactar con INERSOL sl.](#)



Home Power Generation

[[Join Now](#) | [Ring Hub](#) | [Random](#) | [<< Prev](#) | [Next >>](#)]









Nozzle Number				Net Head																
70 Series	80 Series	Nozzle Bore	Nozzle Bore	13	17	21	26	30	34	38	43	47	51	55	60	64	68	72	77	psi
3/8" NPT	3/4" NPT	Inches	mm	30	39	49	59	69	79	89	98	108	118	128	138	148	157	167	177	feet
				9.0	12.0	15.0	18.0	21.0	24.0	27.0	30.0	33.0	36.0	39.0	42.0	45.0	48.0	51.0	54.0	METERS
14		0.219	5.56	0.32	0.37	0.42	0.46	0.49	0.53	0.56	0.59	0.62	0.64	0.67	0.70	0.72	0.74	0.77	0.79	
16		0.250	6.35	0.42	0.49	0.54	0.60	0.64	0.69	0.73	0.77	0.81	0.84	0.88	0.91	0.94	0.97	1.00	1.03	
18		0.281	7.14	0.53	0.62	0.69	0.75	0.81	0.87	0.92	0.97	1.02	1.07	1.11	1.15	1.19	1.23	1.27	1.30	
20		0.313	7.94	0.66	0.76	0.85	0.93	1.00	1.07	1.14	1.20	1.26	1.32	1.37	1.42	1.47	1.52	1.57	1.61	
22	22	0.344	8.73	0.80	0.92	1.03	1.13	1.22	1.30	1.38	1.45	1.52	1.59	1.66	1.72	1.78	1.84	1.89	1.95	
24	24	0.375	9.53	0.95	1.09	1.22	1.34	1.45	1.55	1.64	1.73	1.81	1.89	1.97	2.05	2.12	2.19	2.25	2.32	
26	26	0.406	10.32	1.11	1.28	1.43	1.57	1.70	1.81	1.92	2.03	2.13	2.22	2.31	2.40	2.48	2.57	2.65	2.72	
	28	0.438	11.11	1.29	1.49	1.66	1.82	1.97	2.10	2.23	2.35	2.47	2.58	2.68	2.78	2.88	2.98	3.07	3.16	
	30	0.469	11.91	1.48	1.71	1.91	2.09	2.26	2.42	2.56	2.70	2.83	2.96	3.08	3.20	3.31	3.42	3.52	3.62	
	32	0.500	12.70	1.68	1.94	2.17	2.38	2.57	2.75	2.92	3.07	3.22	3.37	3.50	3.64	3.76	3.89	4.01	4.12	
	34	0.531	13.49	1.90	2.19	2.45	2.69	2.90	3.10	3.29	3.47	3.64	3.80	3.96	4.11	4.25	4.39	4.52	4.65	
	36	0.563	14.29	2.13	2.46	2.75	3.01	3.25	3.48	3.69	3.89	4.08	4.26	4.43	4.60	4.76	4.92	5.07	5.22	
	38	0.594	15.08	2.37	2.74	3.06	3.36	3.63	3.88	4.11	4.33	4.55	4.75	4.94	5.13	5.31	5.48	5.65	5.81	
	40	0.625	15.88	2.63	3.04	3.40	3.72	4.02	4.30	4.56	4.80	5.04	5.26	5.48	5.68	5.88	6.07	6.26	6.44	
	42	0.656	16.67	2.90	3.35	3.74	4.10	4.43	4.74	5.02	5.29	5.55	5.80	6.04	6.26	6.48	6.70	6.90	7.10	
	44	0.688	17.46	3.18	3.67	4.11	4.50	4.86	5.20	5.51	5.81	6.09	6.37	6.62	6.88	7.12	7.35	7.58	7.80	

Nozzle Flow, liters/sec

Nozzle Number				Net Head																
70 Series	80 Series	Nozzle Bore	Nozzle Bore	13	17.3	21.7	26	30.3	34.6	39	43.3	47.6	52	56.3	60.6	65	69.3	73.6	77.9	psi
3/8" NPT	3/4" NPT	Inches	mm	30	40	50	60	70	80	90	100	110	120	130	140	150	160	170	180	FEET
				9.1	12.2	15.2	18.3	21.3	24.4	27.4	30.5	33.5	36.6	39.6	42.7	45.7	48.8	51.8	54.9	meters
14		0.219	5.56	5	6	7	7	8	8	9	9	10	10	11	11	12	12	12	13	
16		0.250	6.35	7	8	9	10	10	11	12	12	13	13	14	15	15	16	16	16	
18		0.281	7.14	9	10	11	12	13	14	15	16	16	17	18	18	19	20	20	21	
20		0.313	7.94	11	12	14	15	16	17	18	19	20	21	22	23	23	24	25	26	
22	22	0.344	8.73	13	15	16	18	19	21	22	23	24	25	26	27	28	29	30	31	
24	24	0.375	9.53	15	17	20	21	23	25	26	28	29	30	31	33	34	35	36	37	
26	26	0.406	10.32	18	21	23	25	27	29	31	32	34	36	37	38	40	41	42	43	
	28	0.438	11.11	21	24	27	29	31	34	36	38	39	41	43	44	46	48	49	50	
	30	0.469	11.91	24	27	31	33	36	39	41	43	45	47	49	51	53	55	56	58	
	32	0.500	12.70	27	31	35	38	41	44	47	49	52	54	56	58	60	62	64	66	
	34	0.531	13.49	30	35	39	43	46	50	53	55	58	61	63	66	68	70	72	74	
	36	0.563	14.29	34	39	44	48	52	56	59	62	65	68	71	74	76	79	81	83	
	38	0.594	15.08	38	44	49	54	58	62	66	69	73	76	79	82	85	88	90	93	
	40	0.625	15.88	42	49	54	59	64	69	73	77	80	84	87	91	94	97	100	103	
	42	0.656	16.67	46	54	60	66	71	76	80	85	89	93	96	100	104	107	110	113	
	44	0.688	17.46	51	59	66	72	78	83	88	93	97	102	106	110	114	117	121	125	

Nozzle Flow, gpm

Nozzle Number				Net Head																PSI feet meters
				15	20	25	30	35	40	45	50	55	60	65	70	75	80	85	90	
70 Series	80 Series	Nozzle Bore	Nozzle Bore	35	46	58	69	81	92	104	115	127	138	150	162	173	185	196	208	
3/8" NPT	3/4" NPT	Inches	mm	10.6	14.1	17.6	21.1	24.6	28.1	31.7	35.2	38.7	42.2	45.7	49.2	52.8	56.3	59.8	63.3	
14		0.219	5.56	6	6	7	8	8	9	10	10	11	11	12	12	12	13	13	14	
16		0.250	6.35	7	8	9	10	11	12	13	13	14	14	15	16	16	17	17	18	
18		0.281	7.14	9	11	12	13	14	15	16	17	18	18	19	20	20	21	22	22	
20		0.313	7.94	11	13	15	16	17	18	20	21	22	23	23	24	25	26	27	28	
22	22	0.344	8.73	14	16	18	19	21	22	24	25	26	27	28	30	31	32	33	33	
24	24	0.375	9.53	16	19	21	23	25	27	28	30	31	33	34	35	36	38	39	40	
26	26	0.406	10.32	19	22	25	27	29	31	33	35	37	38	40	41	43	44	45	47	
	28	0.438	11.11	22	26	29	31	34	36	38	40	42	44	46	48	49	51	53	54	
	30	0.469	11.91	25	29	33	36	39	41	44	46	49	51	53	55	57	59	60	62	
	32	0.500	12.70	29	33	37	41	44	47	50	53	55	58	60	62	65	67	69	71	
	34	0.531	13.49	33	38	42	46	50	53	56	60	62	65	68	70	73	75	78	80	
	36	0.563	14.29	37	42	47	52	56	60	63	67	70	73	76	79	82	84	87	90	
	38	0.594	15.08	41	47	53	58	62	67	71	74	78	81	85	88	91	94	97	100	
	40	0.625	15.88	45	52	58	64	69	74	78	82	86	90	94	98	101	104	107	111	
	42	0.656	16.67	50	57	64	70	76	81	86	91	95	100	104	108	111	115	118	122	
	44	0.688	17.46	55	63	71	77	83	89	95	100	105	109	114	118	122	126	130	134	

Nozzle Flow, gpm

Source File: http://www.geocities.com/turgo_gen/nozzles.xls

Turgo Nozzle Placement

Nozzle placement for a turgo runner is at an angle approximately 20 degrees above the runner's plane of rotation. In contrast a pelton runner and nozzle are co-planar. The 20 degree angle is a nominal or typical value. A lesser angle is preferable for higher efficiency. A value may be calculated based on the nozzle and runner diameters and number of spoons such that the jet is evenly split over 3 spoons.



13. Model of a Pelton wheel with nozzle regulator.

There has been little change in subsequent designs. Small improvements in bucket design and buffer to prevent water splashing back on to the runner have raised the efficiency of large Pelton Wheels to more than 90 per cent. Vertical shaft Pelton Wheels are made in powers up to 10,000 HP, and sometimes as much as 6 jets are used to enable the machine to run at the highest possible speed. Double up to 10 jets may be used.

The Pelton Wheel suffers from the disadvantage that for a runner of a given size diameter, and one meter, there is a maximum diameter of jet which can be used. The ratio of runner diameter to jet diameter is known as the runner jet ratio, and, in very general terms, has a normal minimum value of about 6:1. Hence the bigger jet which could be used on a runner which would be one sixth of a meter (about 11 millimeters) in diameter. To obtain maximum efficiency the velocity of the runner at its mean diameter (the jet center line) should be about half the jet velocity which is fixed by the operating head at the nozzle. If, for example, the head is 100 meters the jet velocity will be 44 meters per second. Hence

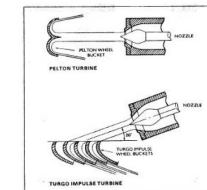

14. Diagram showing the difference in principle between the Pelton Wheel and Turgo Impulse Turbine. Note also the 'split' or 'split' nozzle.

This illustration from an old book (Wilson) shows the difference between Pelton and turgo flow paths.

In practice the nozzle should be placed as closely as possible to the runner, while leaving a safe clearance to prevent contact.

Photo Courtesy of Stuart Fraser
http://www.fraser1.demon.co.uk/index_main.htm

This is a nice photo of a rather busy nozzle design. Here the jet angle is too steep such that the jet isn't spread over three spoons. It also hits the runner a bit before the tangent point. The photo nicely illustrates the flow path.



In order for the jet to divide across three spoons, the jet angle theta, relative to the runner rotation plane is computed as;

$$\theta = \arcsin(\text{nozzle bore} / (3 * \text{spoon spacing}))$$

The spoon spacing is $\pi * (\text{pitch diameter}) / (\text{number of spoons})$.





15 Model of a Pelton wheel with nozzle regulator.

there has been little change in subsequent designs. Small improvements in bucket shapes and baffles to prevent water splashing back on to the runner have raised the efficiency of large Pelton Wheels to more than 90 per cent. Vertical shaft Pelton Wheels are made in powers up to 140,000 HP, and sometimes as many as 6 jets are used to enable the machine to run at the highest possible speed. Heads up to 1,500 metres have been used.

The Pelton Wheel suffers from the disadvantage that for a runner of a given mean diameter, say one metre, there is a maximum diameter of jet which can be used. The ratio of runner diameter to jet diameter is known as the 'runner jet ratio' and, in very general terms, has a normal minimum value of about 9:1. Hence the biggest jet which could be used on a one metre wheel would be one ninth of a metre (about 111 millimetres) in diameter. To obtain maximum efficiency the velocity of the runner at its mean diameter (the jet centre line) should be about half the jet velocity which is fixed by the operating head at the nozzle. If, for example, the head is 100 metres the jet velocity will be 44 metres per second. Hence

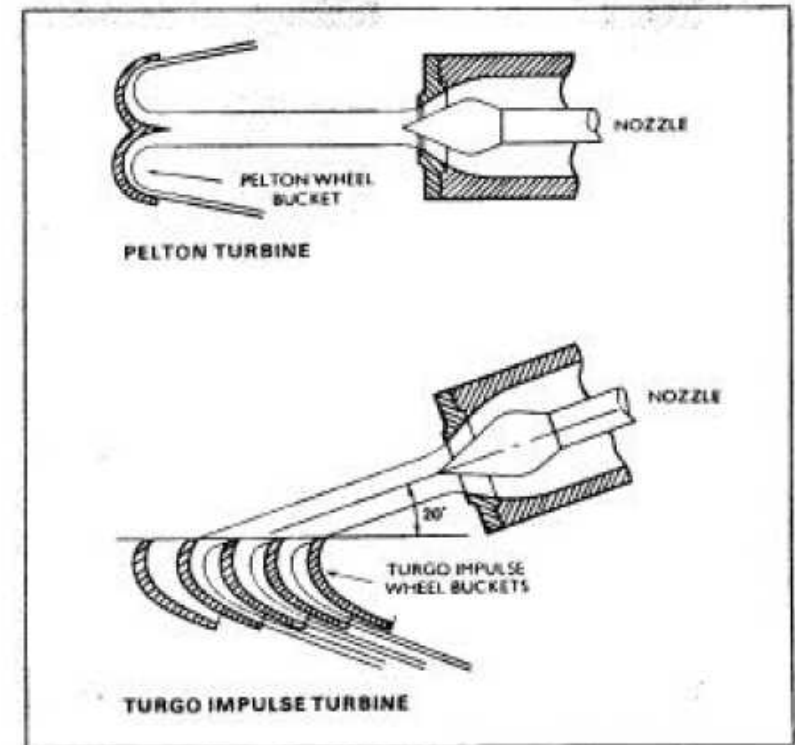

16 Diagram showing the difference in principle between the Pelton Wheel and Turgo Impulse Turbine. Note also the 'spear' or 'needle' nozzle.

You do not need sign-up with propay in order to pay using ProPay. I have an account with them, so you do not need one.

If you have a [PayPal](#) account through [eBay](#), you can also use that to pay to my yahoo email address, joe@h-hydro.com. Signup for PayPal is free, and allows payment from a bank account rather than a credit card. For security purposes their signup process takes several days in order to verify your email address, street address and account information.

To order and pay using propay or by check we do the following.

1. You [email me](#) stating what items you want to order, how you want it shipped, and how you wish to pay (ProPay, PayPal, check, etc.). Also include in your email the shipping address formatted according to your local convention. We will sometimes need to exchange several messages until everything is clearly worked out for both of us, but please stick to email. This is not what I do for a living. I am an engineer in the field of fuel cell R&D and I have school age children at home. So, I request that we try to communicate with email rather than having me try to take phone calls at home or work. I really appreciate your consideration of my family and employer in this matter.
2. I email you with a simple invoice listing the prices and total cost.
3. To use propay, I log onto my propay account and create a request for payment.
4. The propay system sends you an email with a link to a secure web page specific to our transaction and fixed amount.
5. **You click on the link in the propay email, and enter your card information on ProPay's secure server web page that was created just for our transaction. I never see your card info. You are charged exactly the amount agree in USD, but the exchange rate USD to other currency is set by your card bank.** There are no additional fees charged to your card.
6. Propay notifies me that you have paid so I can send your parts. I'm charged about 3.5% for the service.

Propay requires either Visa or Mastercard (EuroCard). Propay has a single transaction limit of 250 USD. For purchases larger than 250 USD, I will process a payment request of \$250 to start the order, with another payment request once the order is ready to ship. Orders over \$1000 USD must be payed by check or wire transfer.

If you prefer you may mail a check payable in USD through a US bank to the address below. Make check in the name of "Joseph Hartvigsen". Many countries provide such a service through a national bank or post office which often have a branch in New York City.

I keep a supply of hubs on hand for bluespoon runners, am usually able to build them within one to two weeks of receiving an order. This depends on availability of spoons and specific arbor types. If I find myself short of spoons it may take up to 8 weeks to get a shipment from Sweden. Orange spoon runners are usually made to order, with typical lead times in the range of 4-8 weeks.

Joseph Hartvigsen
1529 South 400 East
Kaysville, UT 84037 USA



















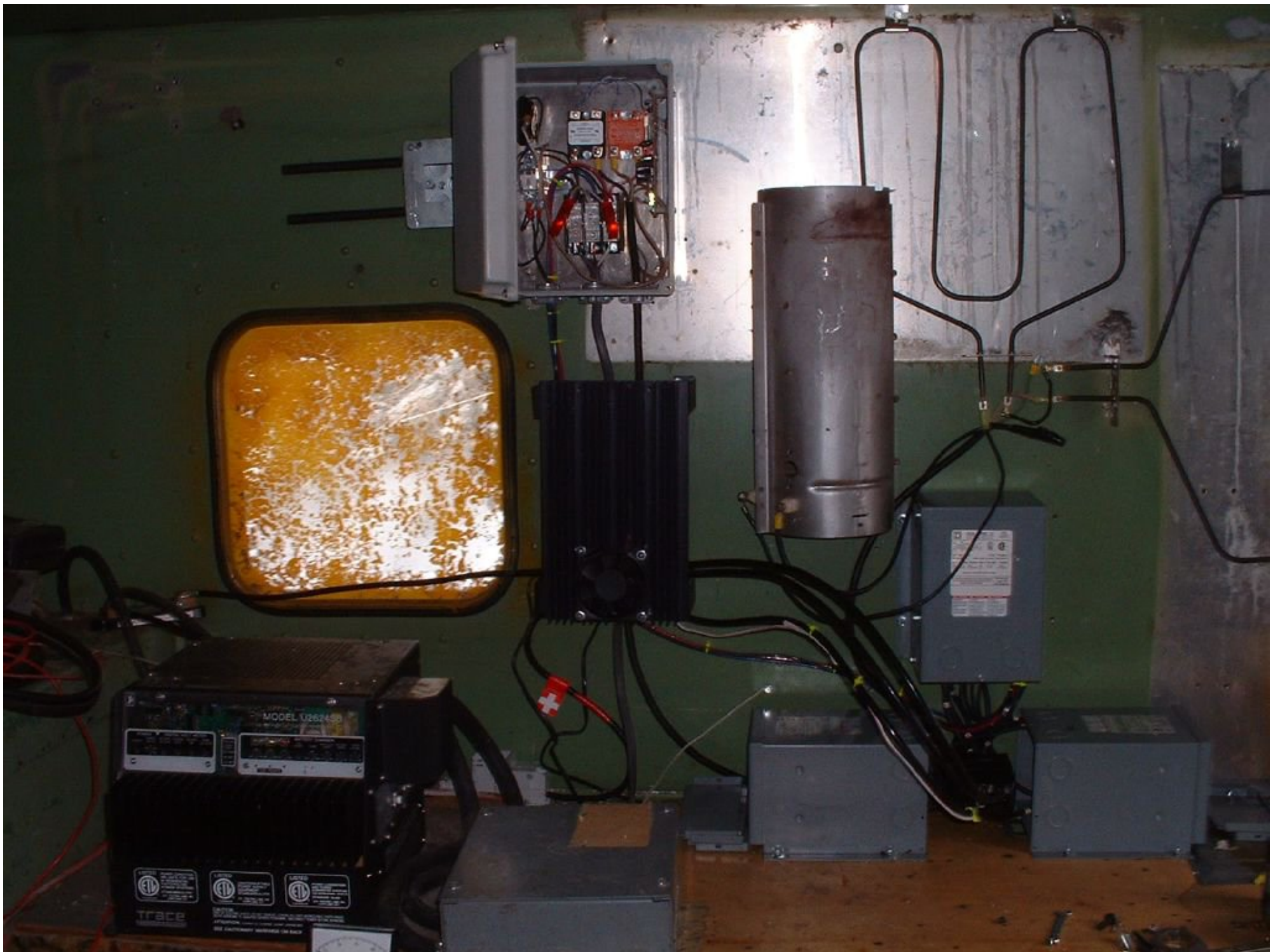



Idaho farm microhydro

Posted by Joseph Hartvigsen to the [microhydro discussion forum](#) on Monday, 04 Jan 1999

We built a system using an ES&D 10 cm plastic pelton runner which I purchased through a local place. The system is on the family farm in the mountains of south eastern Idaho. My father had just put up a new house on the farm as his full time home when I started this. It is miles from power lines so we had to set up a system of our own. He started with a Trace 2624SB inverter and 4 Trojan L-16 batteries charged by an 8kW Miller welder generator running on propane. I am a bit slow getting the system completed. The batteries gave out and were replaced last year with 12 large surplus 2V cells from a mountain top radio installation. The generator is now 5 years old and is on its 2nd engine with 3000-4000 hours total time. We have got some power from the hydro system but it is not delivering at full potential yet.

We started work on the hydro system in the fall of 95 when we put in the pipe. We put in about 1/4 to 1/3 mile (0.4-0.5 km) of 6" (15cm) PVC to get about 92' (28 m) of head. The pipe is buried at least 4' (1.2 m) deep, much deeper in a few spots to maintain grade. The first 20' (6 m) length is 18" (45 cm) diameter with hundreds of 0.5" (12 mm) holes. It was put in a trench parallel to the stream and covered with rock for our intake structure. This way we did not have to excavate or pour concrete in the stream bed. When we were ready for water, a few shovel strokes (human powered) let water run over the intake and back into the natural stream bed again. We then had a few lengths of 8" (20 cm) pipe and an air vent riser before going to 6" (15 cm) for the rest of the run. Near the bottom the pipe crossed the stream under a culvert. The pipe was terminated with a thrust block of 2 yards (~ m³) of concrete which also served as the foundation and floor for a small (3.5'x4.5') powerhouse. A 2" (5 cm) drain line extends out in line with the main line and a 3" (8 cm) riser comes up at one end of the slab. Next to the riser, a 7" deep by 14" wide channel in the concrete floor directs the water back to the stream. The battery bank and inverter are in an old military surplus aluminum "radar shack" near the house, 700-800' (230 m) away. A direct burial #10 AWG 10-2-G cable was installed between the powerhouse and the radar shack.

I used a surplus 3hp 208V induction motor that I got free from work as the

generator. It is mounted on a ~18" (0.5 m) pedestal (shaft horizontal) to allow room for a nozzle above and below. The shaft extends through a Plexiglas wall to keep water off the motor. The water comes up into a PVC cross. A pressure relief valve and pressure gauge are on the top of the cross. From the two sides the water goes out, up on one side, down on the other, out toward the generator then turns to the tangent of the pelton runner. Most of the joints are glued but there are enough threaded joints to give 3 axis of motion to align them. It stays 3" until the last straight sections to the nozzles reduces to 1-1/2" where it goes to ball valves and replaceable brass nozzles. There are a few problems with this compared to a commercial ES&D turgo or Harris pelton. I didn't get it exactly right so the two nozzle "arms" are parallel but offset about 0.5". This makes the upper nozzle jet always hit inboard (motor side) of the splitter on the pelton runner. The lower "arm" flow path (over-down-over-up) tends to collect debris until the nozzle plugs. Alignment can be like taking a very cold, very strong shower (unless the big drain valve is open for 5 min first).

The pipe and concrete were done late 95. I put in the generator, nozzles, pelton, etc. and started it up late spring 96. My brother in law was making a LCB (switch mode buck DC-DC converter) which he tried and fried on Thanksgiving Day (Nov) 96. After a succession of failures he put in an old industrial 24V transformer based charger about Labor Day in 97, our first power to the batteries. We just got 5A for a couple of months until it was discovered (about Thanksgiving 97) that the lower nozzle was plugged. After cleaning and aligning the nozzles, he got 15-16A. Then a new problem came up. Due to my father's watt watching the batteries overcharged, the inverter shut off due to high voltage which only made it worse. The charger had a regulator in it, but it was designed for fixed voltage input. Here, as the regulator squeezed off the current, the input voltage would go up making the regulator work even harder. My solution was to take the "window watcher" circuit in Home Power Magazine and have it trigger an AC solid state relay which would connect a load across the AC to put the brakes on the generator. The load was an old heating element from an electric clothes dryer which we mounted on the aluminum wall of the radar shack by the charger. This worked until about this past Labor Day when the overworked regulator in the charger burned out. We just need to bypass it as it isn't effective and only fights itself.

A little over a year ago I started looking into LCB type systems for my work. We are developing fuel cell systems and want to control the fuel cell voltage. We purchased two units from SunSelector. They are nice but not quite what we need. We had a consultant design and build custom units for us. It is a two part design. We have a control board that works for a wide range of systems and a power module which is made for the needed voltage and current. The consultant had some left over parts when we were done and made me a control board. I built a power module a blew it up about a year ago, and a few times since. The consultant, in helping me with the

farm system figured out problems which also affect our SOFC units at higher voltages. We redesigned the board and are just getting the new ones. It has fixed problems we were having with higher voltage fuel cell systems, and I expect it will work well with my hydro system too. The hydro system is much more challenging to the electronics than the current fuel cells. Our biggest fuel cell will be 100-110VDC while the 265VAC hydro goes to ~360VDC at open circuit. It also has considerable kinetic energy to be absorbed as voltage (speed) is changed. Otherwise, they both have a nice linear I-V curve and parabolic power curve. I may test it on the hydro later this month. It's a shame to have all that investment in pipe and trenching and still have to run the generator so much.

The nozzle alignment (and possibly the shallow bucket design) are hurting performance considerably. There are two attachments which are both in Acrobat format. One shows [my calculations](#) estimating that power should be at least close to 800W at the battery (92' eff head 2 nozzles 0.5"). The other shows [single \(upper nozzle\) performance](#). This was measured AC across two phases with resistors at the radar shack. Two nozzle OCV (freewheel voltage) is 265V AC. I didn't measure the I-V curve with both nozzles but if I cut the single nozzle slope in half and start at 265V I get a peak power of ~400W. This is also the best power we have seen DC to the battery (16A).

I have built a 16 bucket turgo with "spoons" from [Cargo&Kraft](#) with a 15 cm hydraulic diameter. I may get a chance to try the turgo runner in a few weeks. I can send a jpeg picture if there is any interest. I also have some [pictures of old Sulzer turbines](#) if there is any interest.

I'm curious how much a new ES&D bronze turgo might put out with this head and two 0.5" nozzles? I also wonder if a permanent magnet or induction generator would be best for high voltage transmission?

Another design choice relates to AC vs. DC transmission. What are the pros and cons of AC->transformer, or DC-> buck regulator? I've been doing some calculations recently on how to size transformers and choke filters if there is interest. I have a list of resources on this I'll post separately.

Joseph Hartvigsen, ChE

TO [microhydro web portal](#)



Last modified on 11 January 1999 by [Wim Klunne](#)

Please note that Wim Klunne cannot be held responsible for the contents of the documents placed here, nor for any copyright violation by documents provided by eGroup members.

For questions in relation to this, please contact the provider of the document/file/image.

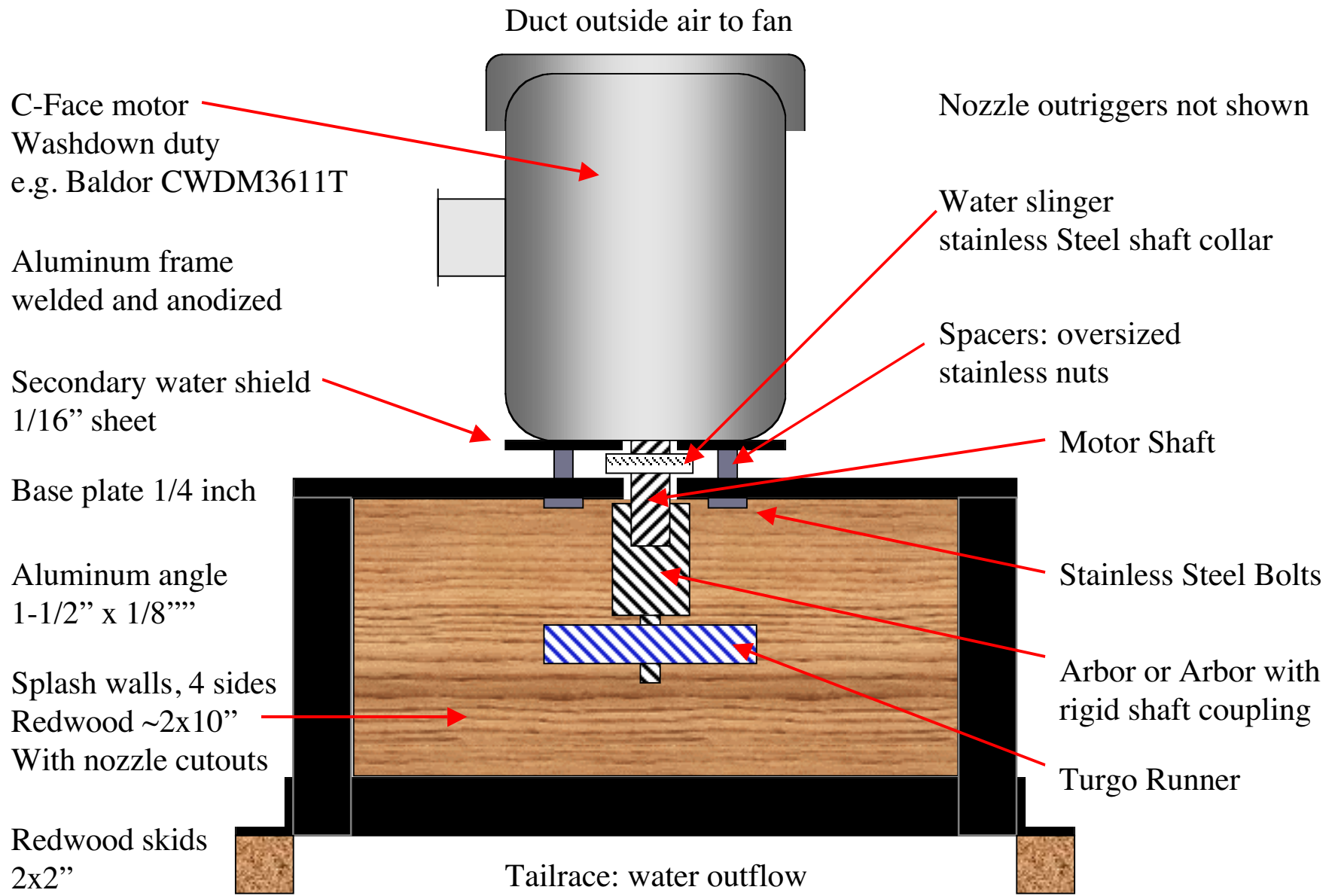

November 8, 2001

Hartvigsen-Hydro

turgo_gen@yahoo.com

Splash Walls

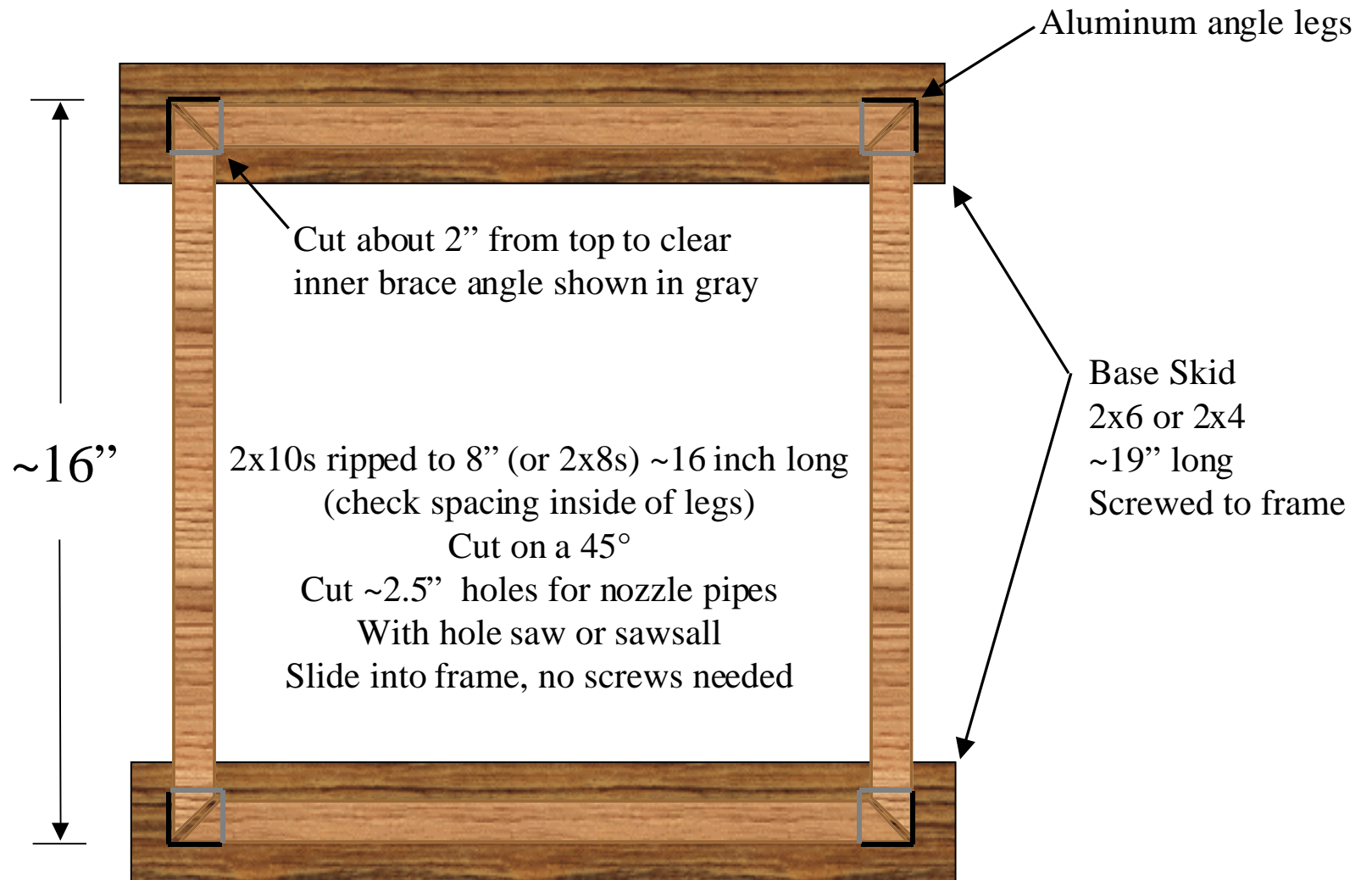

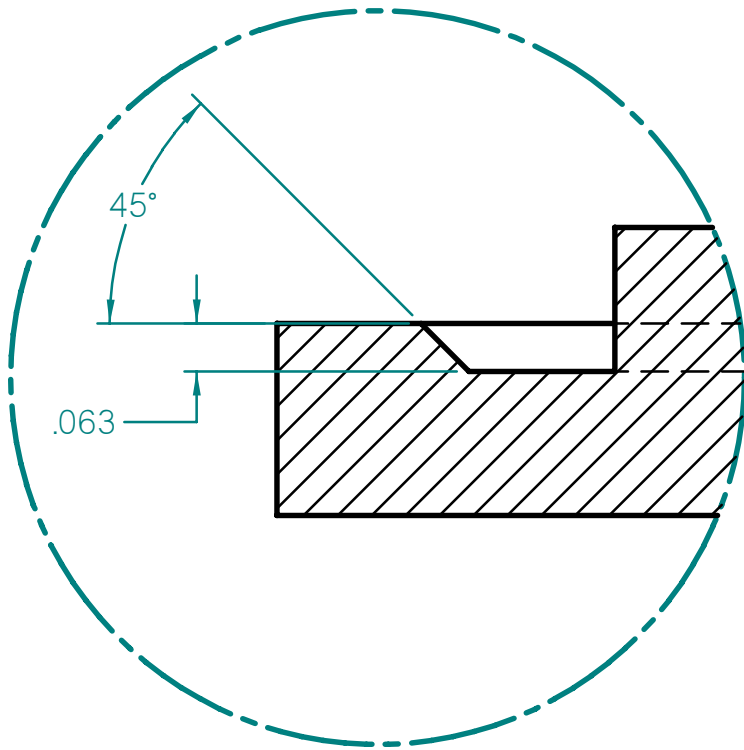
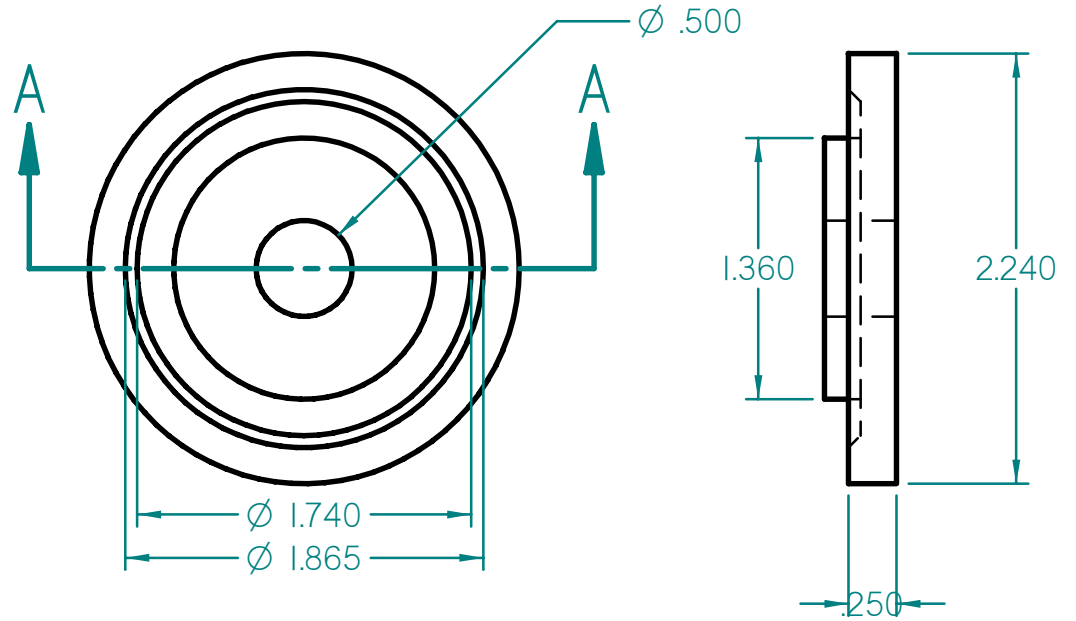
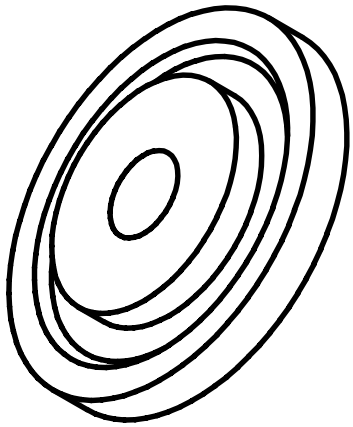

DETAIL B
4:1

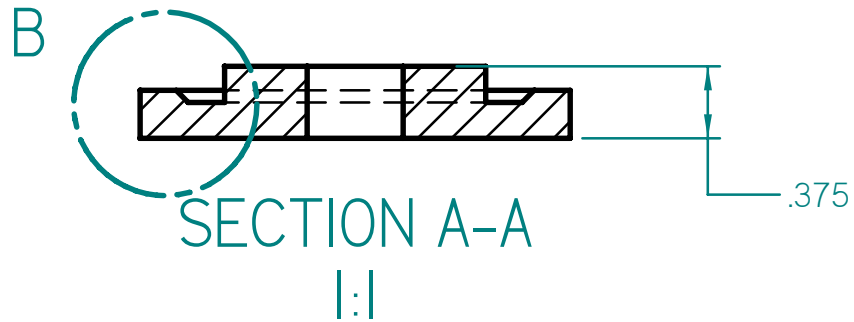

UNLESS OTHERWISE SPECIFIED DIMENSIONS ARE IN INCHES		Hartvigsen-Hydro	
Support washers 2.0" dia turgo_gen@yahoo.com		20 Blue Spoon Runner	
MATERIAL: Delrin	SIZE A	Rev:0	01 May 2001
DO NOT SCALE DRAWING	CAD FILE: blue20.dft		SHEET 1 OF 2

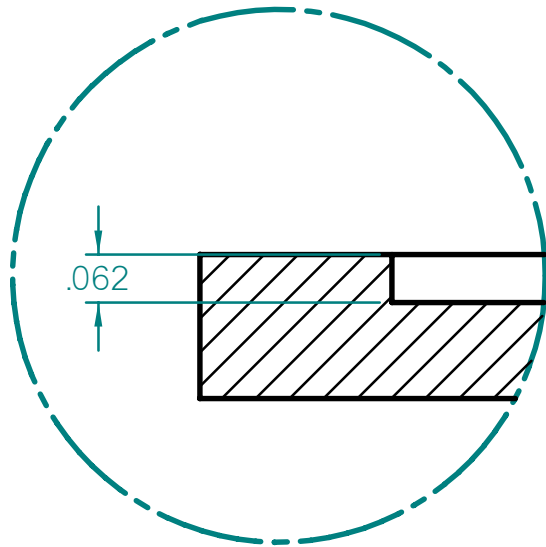
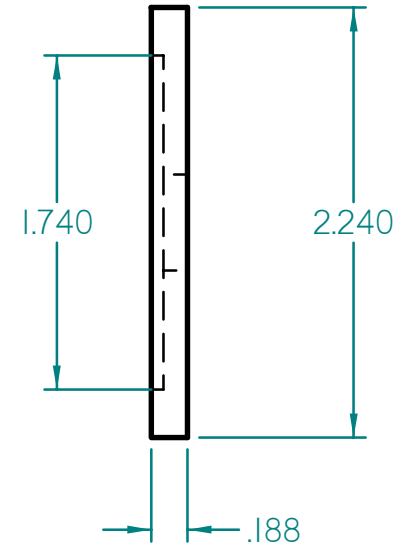
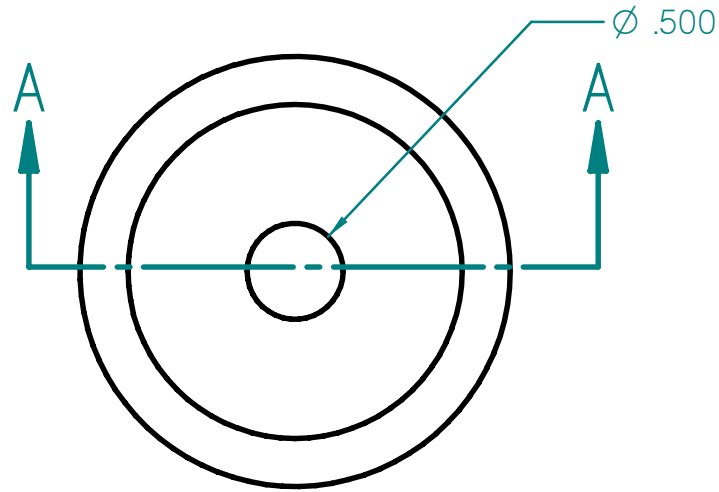
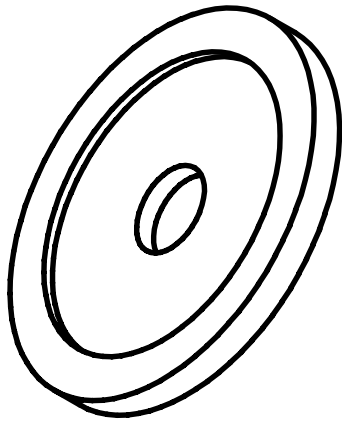

SECTION A-A
1:1

DETAIL B
4:1

UNLESS OTHERWISE SPECIFIED DIMENSIONS ARE IN INCHES		Hartvigsen-Hydro	
Support washers 2.0" dia turgo_gen@yahoo.com		20 Blue Spoon Runner	
MATERIAL: Delrin	SIZE A	Rev:0	01 May 2001
DO NOT SCALE DRAWING	CAD FILE: blue20w.dft		SHEET 2 OF 2

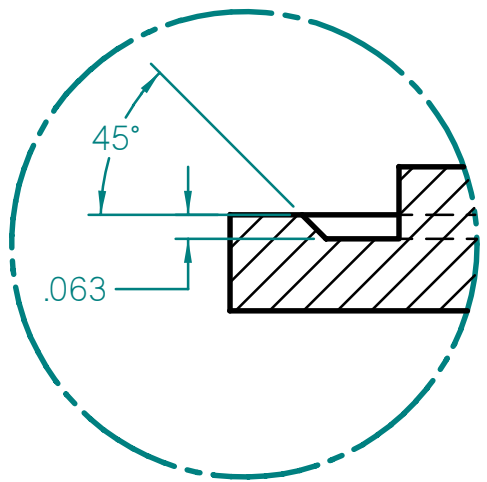
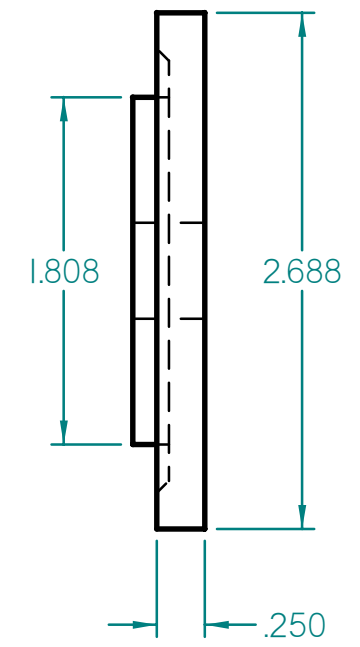
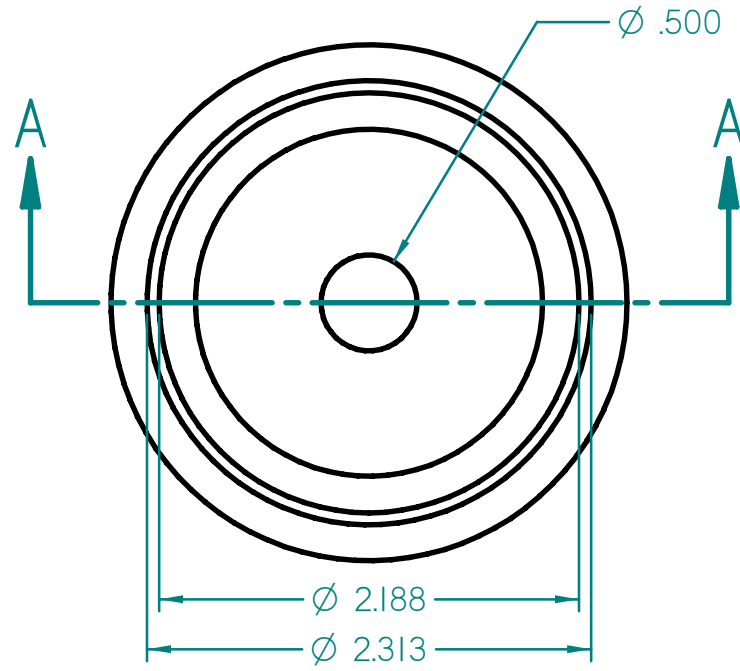
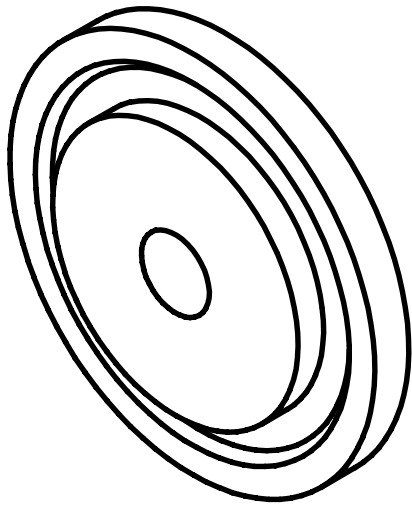

DETAIL B
2:1

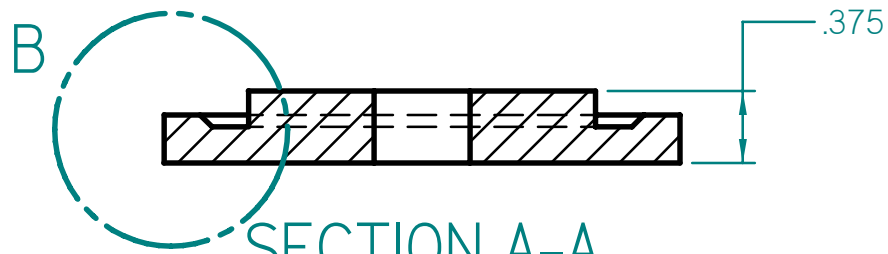

SECTION A-A
1:1

UNLESS OTHERWISE SPECIFIED DIMENSIONS ARE IN INCHES		Hartvigsen-Hydro		
Support washers 2.5" dia turgo_gen@yahoo.com		24 Blue Spoon Runner		
MATERIAL: Delrin	SIZE A	Rev: Draft	16 April 2002	
DO NOT SCALE DRAWING	UNTESTED PART	CAD FILE: blue24hub.dft	SHEET 1 OF 2	

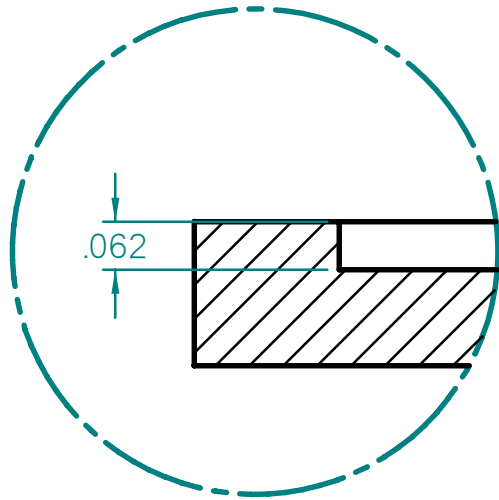
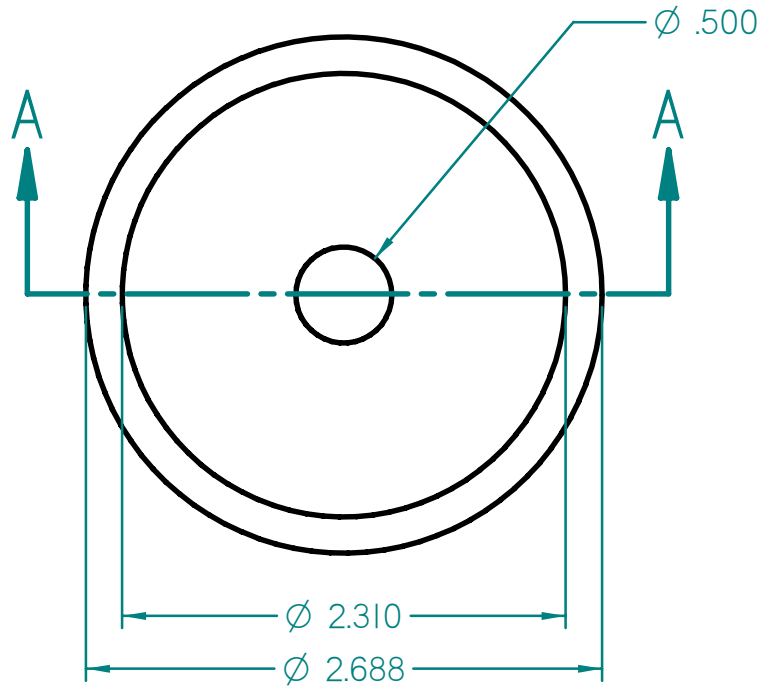
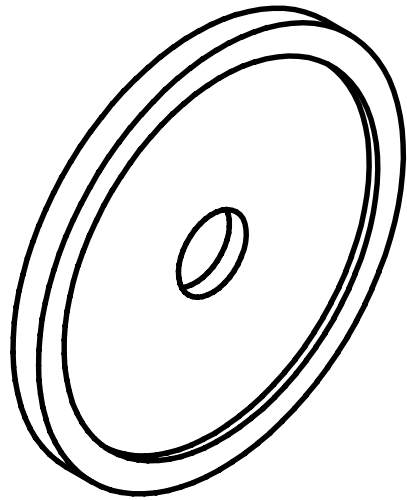

DETAIL B
4:1

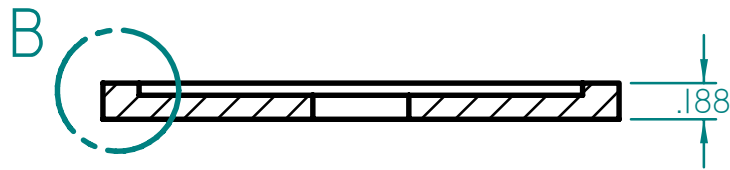

SECTION A-A
1:1

UNLESS OTHERWISE SPECIFIED DIMENSIONS ARE IN INCHES		Hartvigsen-Hydro		
Support washers 2.5" dia turgo_gen@yahoo.com		24 Blue Spoon Runner		
MATERIAL: Delrin	SIZE A	Rev: Draft	16 April 2002	
DO NOT SCALE DRAWING	UNTESTED PART	CAD FILE: blue24w.dft	SHEET 2 OF 2	

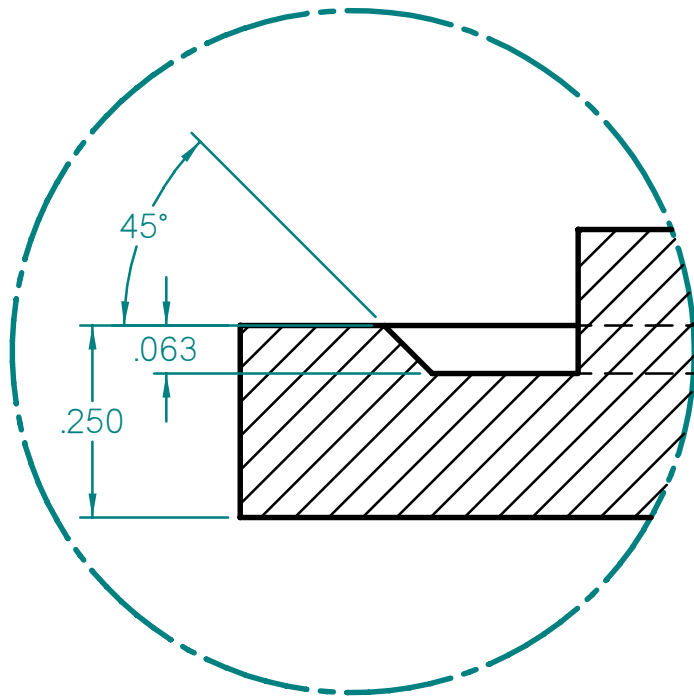
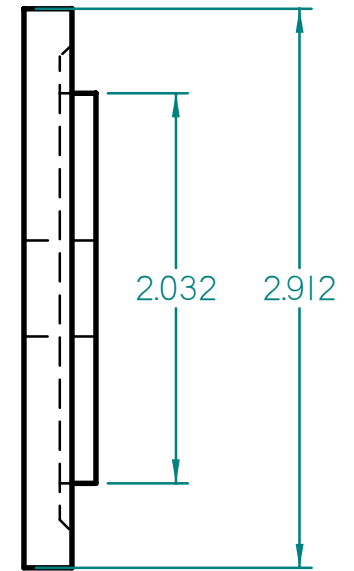
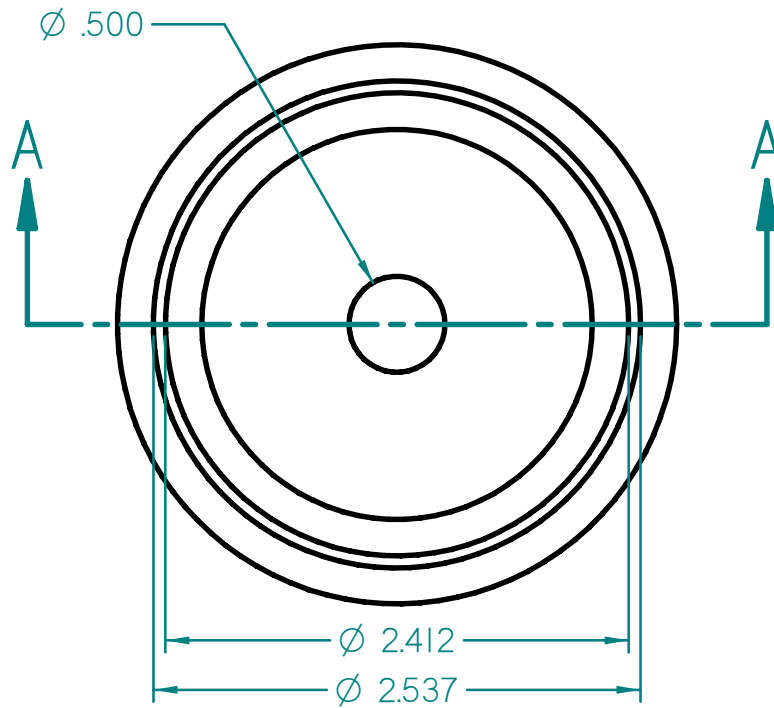
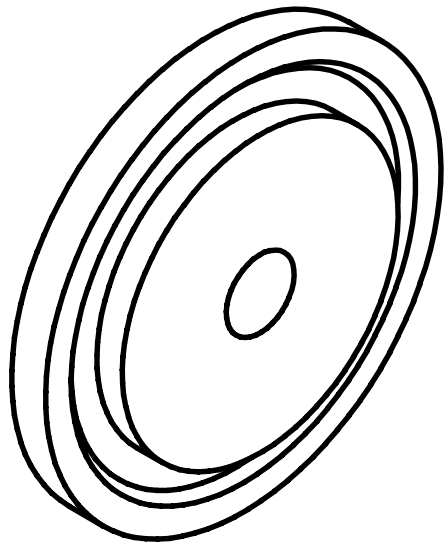

DETAIL B
4:1

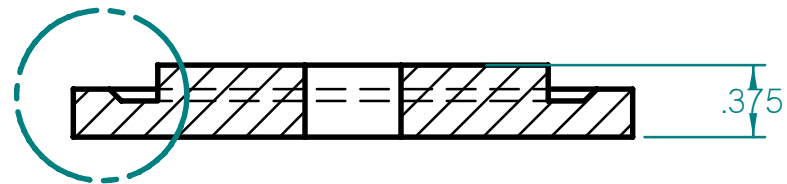

B SECTION A-A
1:1

UNLESS OTHERWISE SPECIFIED DIMENSIONS ARE IN INCHES		Hartvigsen-Hydro		
Support washers 2.75 dia turgo_gen@yahoo.com		26 Blue Spoon Runner		
MATERIAL: Delrin	SIZE A	Rev: Draft	16 April 2002	
DO NOT SCALE DRAWING	UNTESTED PART	CAD FILE: blue26hub.dft	SHEET 1 OF 2	

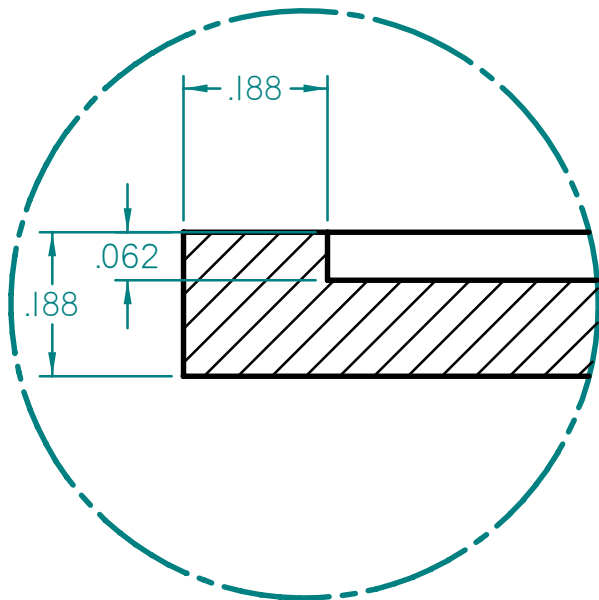
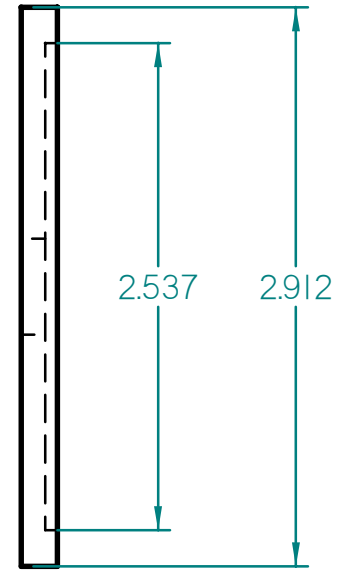
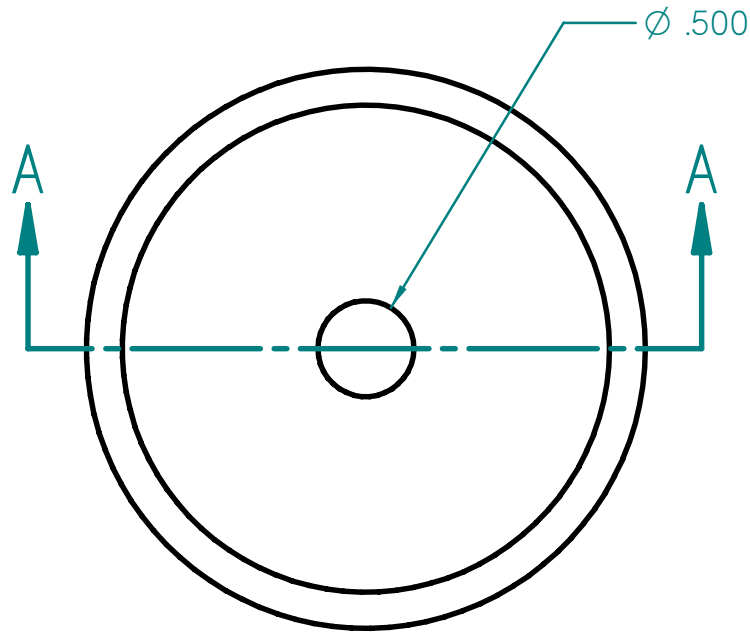
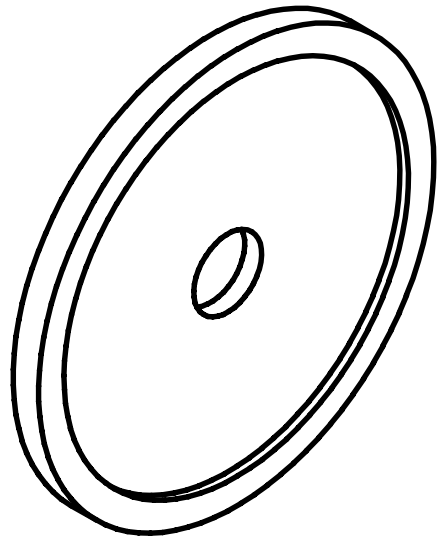

DETAIL B
4:1

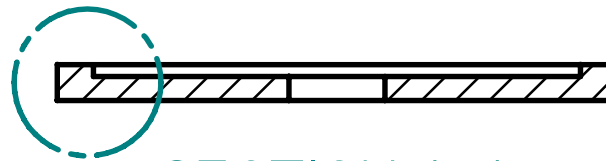

B SECTION A-A
1:1

UNLESS OTHERWISE SPECIFIED DIMENSIONS ARE IN INCHES Support washers 2.75 dia turgo_gen@yahoo.com	Hartvigsen-Hydro		
	26 Blue Spoon Runner		
MATERIAL: Delrin	SIZE A	Rev: Draft	16 April 2002
DO NOT SCALE DRAWING	UNTESTED PART	CAD FILE: blue26w.dft	SHEET 2 OF 2

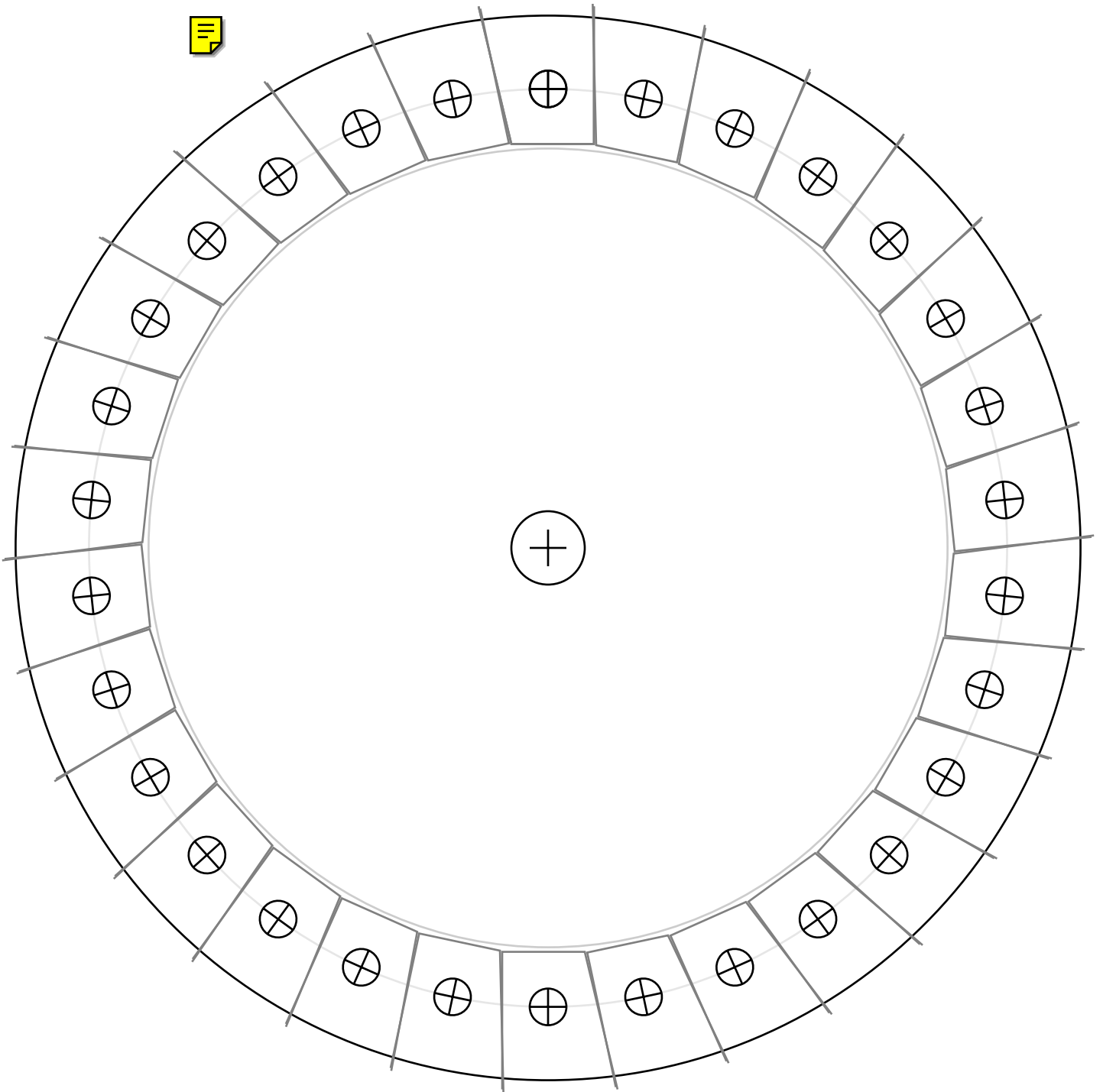

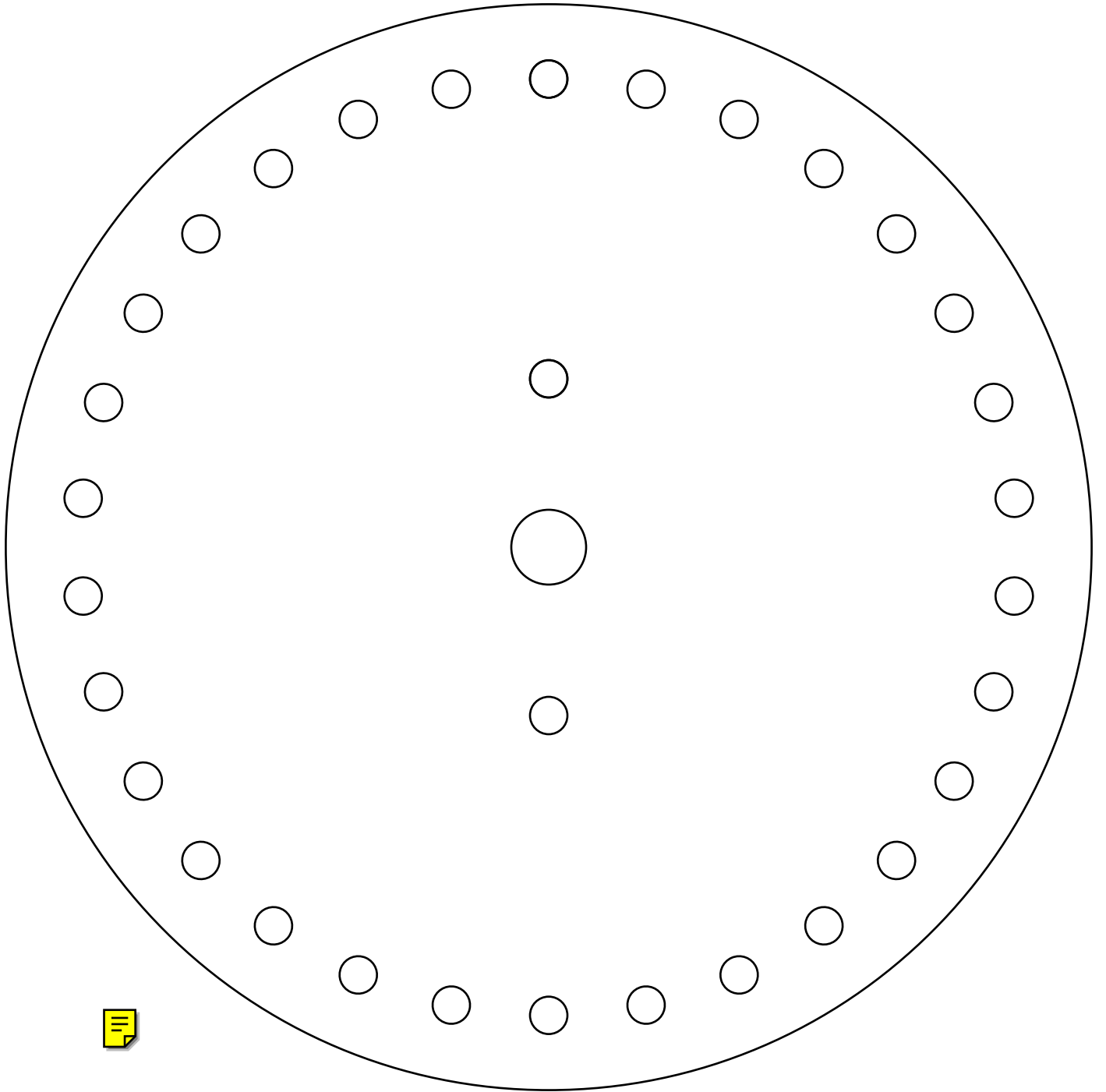

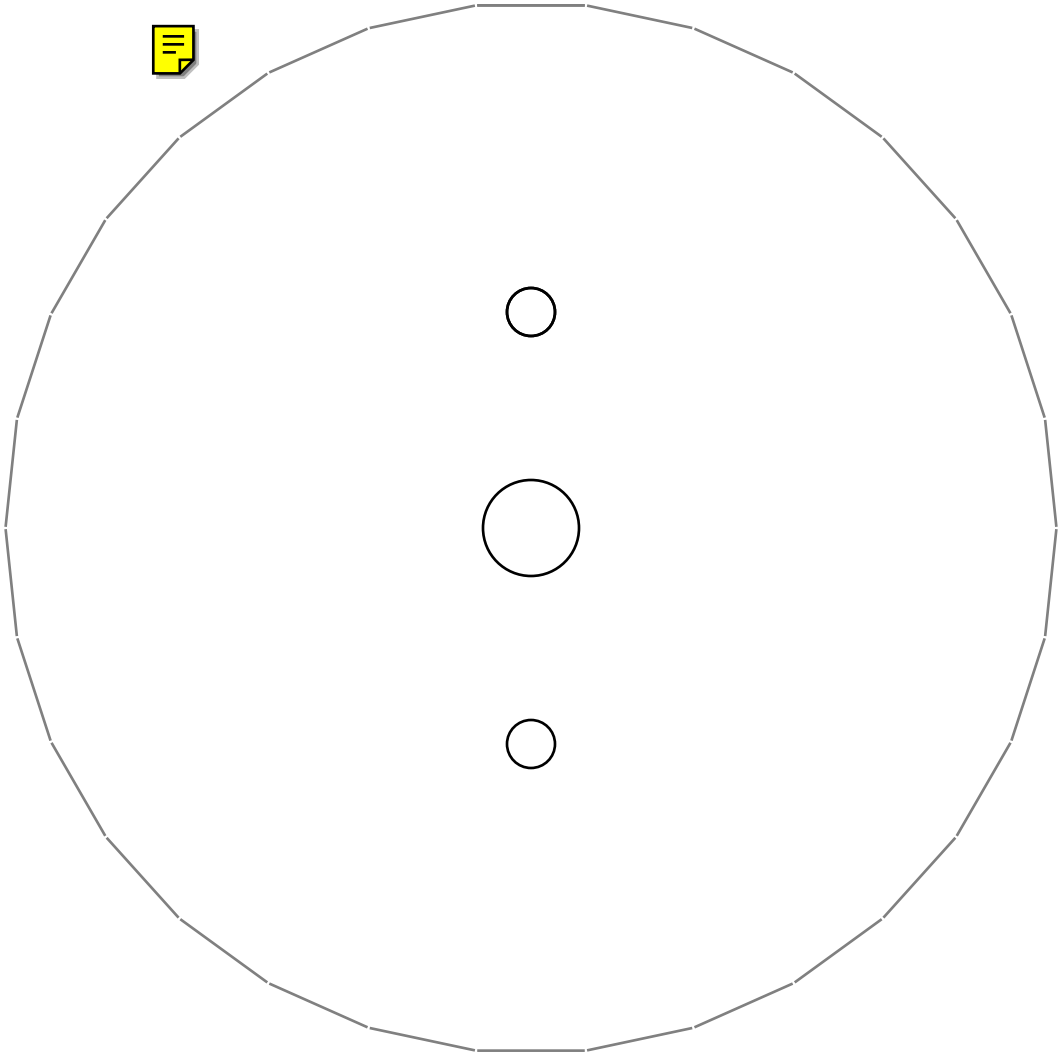

S M I T H | H A R T V I G S E N PLLC

ATTORNEYS AT LAW

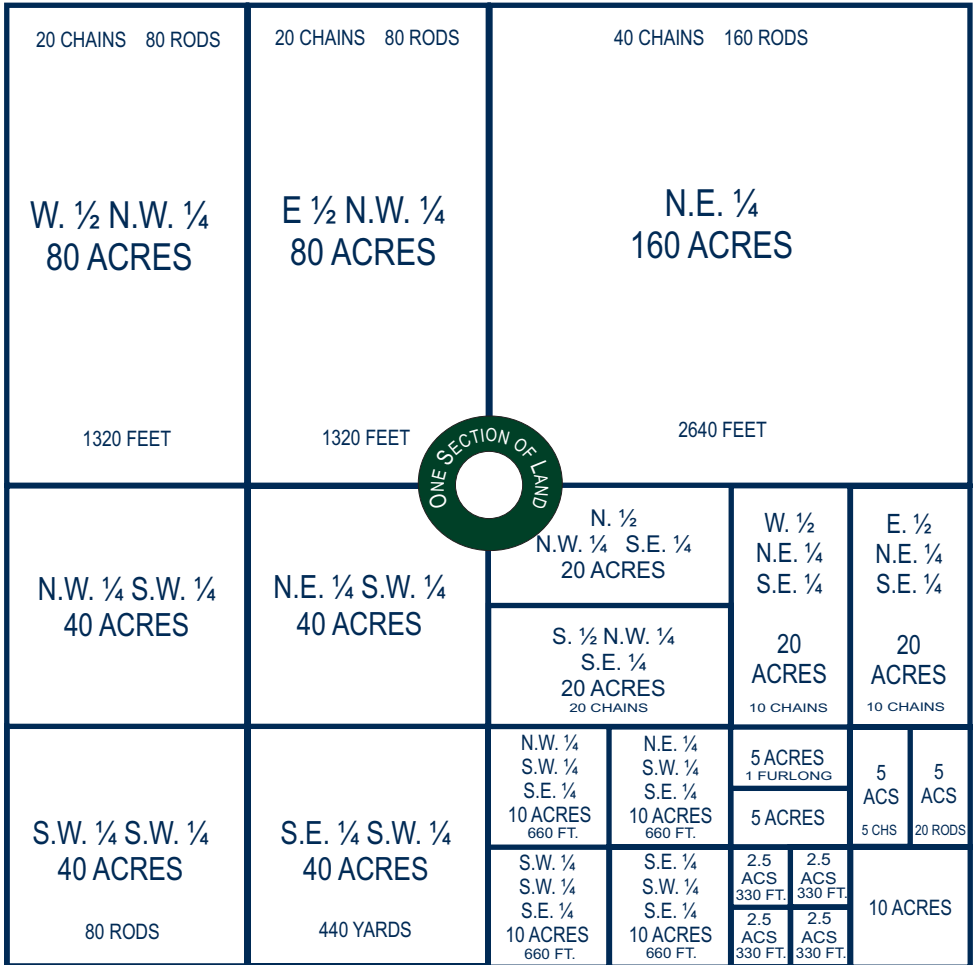

ONE SECTION OF LAND CONTAINS ONE SQUARE MILE OR 640 ACRES

- 1 LINK = 7.92 INCHES
- 1 ROD = 5.5 YARDS = 16.5 FEET = 25 LINKS
- 1 CHAIN = 4 RODS = 66 FEET = 100 LINKS
- 1 FURLONG = 40 RODS = 660 FEET
- 1 MILE = 8 FURLONGS = 80 CHAINS = 320 RODS = 5280 FEET
- 1 SQUARE ROD = 30 1/4 SQUARE YARDS = 272 1/4 SQUARE FEET
- 1 ACRE = 160 SQUARE RODS = 43,560 SQUARE FEET (208.7 x 208.7)
- 1 ACRE IS 8 RODS x 20 RODS (OR ANY TWO NUMBERS OF RODS WHOSE PRODUCT IS 160)



(This information is provided "as is" without any express or implied warranty of accuracy.)

S M I T H | H A R T V I G S E N PLLC

ATTORNEYS AT LAW

WATER CONVERSION CHART

VOLUME	gallons	cubic feet	acre feet	million gallons
One gallon equals	1	0.1337	0.00000307	0.000001
One cubic ft equals	7.48051	1	0.00002296	0.0000075
One ac-foot equals	325,851	43,560	1	0.32585
1 M gallons equals	1,000,000	133,680	3.0689	1

FLOW	gallons	cubic feet	acre feet	million gallons
One gallon per minute equals				
Second	0.01666667	0.002228	---	---
Minute	1	0.13368	0.0000031	0.000001
Hour	60	8.0208	0.00018	0.000060
Day	1,440	192.5	0.00442	0.001440
30-day month	43,200	5775	0.1326	0.043200
365-day Year	525,600	70,262.5	1.613	0.525596

One cubic foot per second equals				
Second	7.48051	1	---	---
Minute	448.83	60	0.0013771	---
Hour	26930	3600	0.082625	---
Day	646,315	86400	1.983	0.6462
30-day month	19,389,450	259,200	59.5	19.386
365-day Year	235,904,975	31,536,000	723.97	235.9

One acre-foot per year equals				
Second	0.01033	0.00138	---	---
Minute	0.62	0.083	---	---
Hour	37.198	4.973	0.0001142	---
Day	892.7425	119.343	0.00274	0.00089
30-day month	26,782	3,580	0.0822	0.02678
365-day Year	325,851	43,560	1	0.32559

One million gallons per day (MGD) equals				
Second	11.5741667	1.54721667	0.00004	---
Minute	694.45	92.833	0.0021	0.0007
Hour	41,667	5570	0.127875	0.04167
Day	1,000,000	133,680	3.069	1
30-day month	30,000,000	4,010,400	92	30
365-day Year	365,000,000	48,793,200	1,120.147	365

Note: Irrigation season of April to October (183 days), April through October (213 days.)

CONSUMPTIVE USE/ SOURCE REQUIREMENTS

Est. peak use in gallons per day	Culinary	Waste-water
Per Equivalent Residential		
Connection: ERC	800	400
High School Student	25	25
Hotel Guest	150	125
Hospital Bed	250	250
Recreational Home	400	400
Skier	10	5
Restaurant Seat	35 - 50	35
Tavern or Bar Seat		2
Swimmer*	10	

* Calculate swimming pools using water surface area as follows: 20 x Water Area (F12) / 30OE + Deck Area (F12).

Sources: Utah Admin. Rules R309-510-7 and R317-5-1.

Estimated Annual Use

	acre feet	gallons
Per Family	0.045	14,663.3
Cow or Horse	0.028	9,123.8
Pig, Sheep, Elk, Goat, or Moose	0.0056	1,824.8
Ostrich or Emu	0.0036	1,173.1
Llama	0.0022	716.9
Deer, Antelope, Mt. Goat/Sheep	0.0014	456.2
Chicken, Turkey or Sage hen	0.00084	273.7
Mink or Fox (caged)	0.00005	16.3

Source: Utah Div. of Water Rights

DUTY VALUES - Requirement of water per irrigated acre in these areas or counties.

(Duty is the total amount of water used for irrigation expressed in acre-feet per acre. The duty is equivalent to the consumptive irrigation requirement plus the return flow.)

3 acre-foot duty per acre

West Box Elder, Daggett, Rich, Southern Cache and Summit Counties and the Upper Sevier River Drainage

4 acre-foot duty per acre

Beaver, Iron, Millard, Tootle, Northern Cache, and Utah Counties and the Lower Sevier River Basin and South of the San Juan River.

5 acre-foot duty per acre

Salt Lake County, Kanab and Johnson Creek in Kane County, and East of Green/Colorado Rivers in Grand and San Juan Counties.

(This information is provided "as is" without any express or implied warranty of accuracy.)

215 South State Street
Suite 650
Salt Lake City, Utah 84111



T 801.413.1600
F 801.413.1620
www.smithhartvigsen.com