

# Induction Motors for Small-Scale Hydro



Bill Haveland

©1999 Bill Haveland

Richard & Nancy Lebo's 2 HP induction motor making juice in Costa Rica.

The standard three-phase induction motor is very well suited for hydroelectric generation. These motors, functioning as generators, can be used for both battery charging and stand-alone applications.

Induction motors are especially useful on streams and springs situated a long distance from where the power will be used. Excessive wire loss in these situations makes transmitting low voltage functionally impractical. The generation voltage of induction generators is typically from 120 to 480 volts, compared to the 12 to 48 volts of the small turbines commonly available on the market. This technology opens up many potential generation sites that were not previously usable with existing turbines.

## Economical & Low Impact

A 1 1/2 horsepower (HP) induction motor, generating at 500 watts, produces about 12 KWH per day, which is equivalent to fifty 75 watt PV panels installed in Phoenix, Arizona. The PV panels would cost nearly

\$18,000; the hydro turbine generator would only cost about \$2,000. Where the water resource exists, and local legal and social structures allow its use, battery charging hydro is almost always the most economical source of off-grid power.

With careful site development, small hydro installations, which generally do not use large impoundment structures, have a very low environmental impact. Where there are other creatures using the same water, consideration for their well-being should be practiced in all stages of development and operation.

Richard & Nancy in front of their hydro-powered home.



This article presents an overview of the technology with its advantages and disadvantages. For more on induction generator theory, see *HP3*, page 17, and sources at the end of this article. I've listed some of the pitfalls that I've learned from experience, and included a simplified development procedure to help you put your own hydro to work. Sources, suppliers, and references are listed at the end of the article.

## Advantages of Induction Generators

### 1. Readily Available

Three-phase induction motors are readily available nearly everywhere in the world—new, used, or reconditioned. These motors are manufactured in a wide variety of voltages, efficiencies, case types, service applications, and rpm configurations. This makes it possible to locate a motor to fit nearly any site, except those with very low head.

All motors used as generators in hydro applications should be of the totally enclosed fan-cooled (TEFC) type, with severe duty motors preferred. C-face motor mounting is usually used for direct coupling the motor to the runner. Harris Pelton or four inch (10 cm) Turgo runners are the products generally selected for most home-scale battery charging applications. The C-face mount limits the selection of suitable motors somewhat. High-power turbines or motors with standard mounting can be belt coupled, through a jack shaft, to the turbine runner.

The C-face motor is designed for bolting the turbine housing directly to the shaft end of the motor. Adapting the Harris or Turgo turbine runners to the selected C-face motor will require one of three things: making a coupling adapter, ordering the turbine runner with a keyway the same diameter as the motor shaft, or machining the motor shaft to match that of a Ford alternator. Ford and Delco are the most commonly used high output automobile alternator models in microhydro applications, and most runners are built with shaft sizes to fit them.

### 2. Inexpensive

A new, premium-efficiency, severe duty, 1 1/2 HP, 1,800 rpm, 230 V/460 V, 56C-face, TEFC, three-phase motor will cost US\$200 to \$450. These motors are also available reconditioned at a significant discount. This initial cost is similar to the DC Ford and Delco alternators now used on small hydros, but these alternators require frequent rebuilds and have a limited life expectancy.

The complete hardware package of an assembled turbine for a 1 1/2 HP motor—induction generator, capacitors, capacitor enclosure, fuses, transformer, and rectifiers—will cost about US\$2,000 to \$2,500. Where



**A typical filter tank at the top of the Lebos' penstock.**

the turbine is closer than 500 feet (152 m) to the batteries, the less expensive (US \$900–1,400) and more efficient low voltage DC alternator should be used. The additional cost of the induction machine can be attributed to components that are unnecessary with the low voltage DC machine. These include capacitors, transformer, protection devices, wiring, and rectifiers with their enclosures. Though induction generators are somewhat more expensive up front, they can outlast conventional alternators many times over.

### 3. Very Robust

These generators will last decades, with bearing replacement every three to five years of continuous service, if they are set up properly to begin with. The

**At the DC end, 258 V is stepped down to 24 V.**





The Bosque del Cabo system utilizes a 1 1/2 HP motor (left) to produce 180 watts from 21 gpm at 190 feet of head. 2,300 feet from the hydro unit, the rest of the system (right) steps down from 415 VAC to 12 VDC.

motor design is meant to withstand many years of industrial use and abuse. There are no brushes, slip rings, diodes, or wire windings on the rotor to fail.

Not having windings on the rotor allows the generator to tolerate significant sustained overspeed without damage. The sealed machine housing provides excellent protection against dust and liquids. Induction generators will survive serious mechanical and electrical abuse that would kill automotive alternators.

#### 4. Inherently Overload Protected

Sooner or later, a short circuit will be applied to the generator output. This might be caused by shorted wires in the transmission line or defective components in the battery charging system. With this type of failure, the generator will lose excitation and spin freely without suffering damage. If an overload occurs in the distribution of a stand-alone system, it will also cause the generator to lose excitation and begin to freewheel.

In contrast, a turbine using a Ford or Delco alternator subjected to a short on the output will cause the alternator to burn up. The induction generator will not restart until the overload is corrected. Although induction motors are inherently overload protected, runaway overload protection is necessary to protect against a disconnected load. This scenario is dealt with under *Disadvantages of Induction Generators*.

#### 5. Can Generate at a High Voltage

Because induction motors generate at high voltages, long distance transmission is possible using light gauge, inexpensive wire. For example, a 575 volt motor generating at 480 volts can transmit 750 watts with 5 percent voltage loss for one mile (1.6 km) on two strands of #12 (3.3 mm<sup>2</sup>) wire. This high voltage generation, transmitted over inexpensive wire, makes it possible to harness streams previously deemed too far away for battery charging hydro.

### Induction Generator Wiring

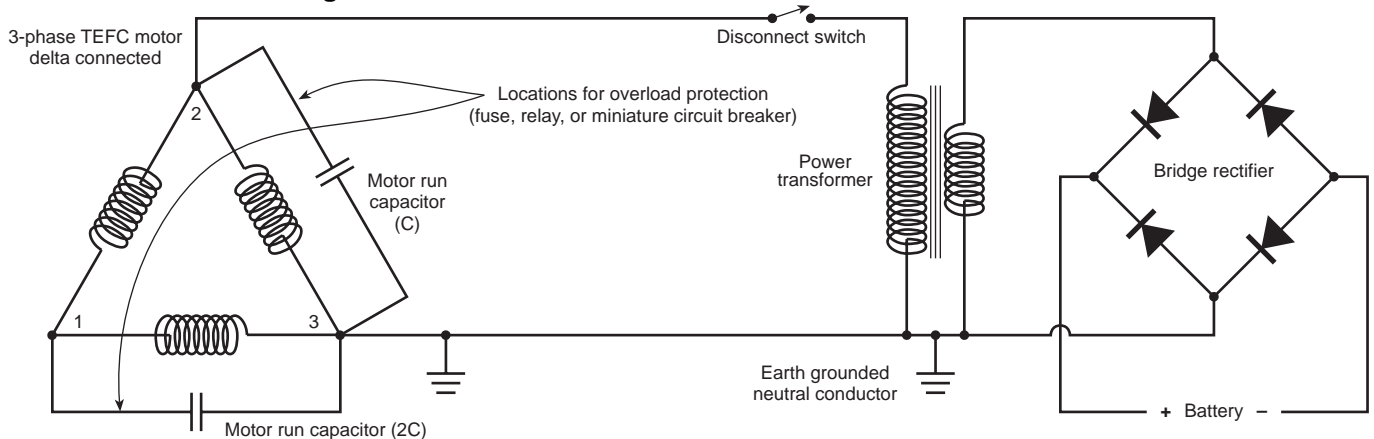



## Induction Hydro System Comparison

Owner	Bosque Del Cabo Lodge	Buena Vista Lodge	Casa Corcovado Lodge	Richard & Nancy Lebo	Joel Stewart & Belen Momene	German Llano
Motor manufacturer	Brooke Hansen	Brooke Hansen	Brooke Hansen	Baldor	Baldor	ESD (3 Phase Alternator)*
Motor rpm	3,600	1,800	1,800	1,200	1,200	N/A
Motor HP	1.5	1.5	1.5	2	2	N/A
Motor volts	575	575	575	480	480	N/A
Generation volts	415 VAC	415 VAC	386 VAC	258 VAC	334 VAC	28 VDC
Generation hertz	66	65	71	85	70	N/A
Test flow	21 gpm	55 gpm	60 gpm	300 gpm	185 gpm	73 gpm
Test net head	190 ft	81 ft	148 ft	55 ft	65 ft	55 ft
Net water potential	750 watts	840 watts	1,670 watts	3,100 watts	2,250 watts	760 watts
Turbine manufacturer	Harris / Pelton	Harris / Pelton	Harris / Pelton	ESD / Turgo	ESD / Turgo	Harris / Pelton
Turbine / generator efficiency	28.0%	50.0%	26.9%	17.1%	32.9%	60.5%
Transmission line efficiency	90.5%	97.6%	95.6%	90.6%	94.6%	97.8%
Transmission line length	2,300 ft	2,500 ft	1,600 ft	1,300 ft	1,100 ft	300 ft
Transmission line gauge	#12	#12	#12	#12	#10	#2
Transformer efficiency	97.4%	96.3%	97.7%	89.6%	95.7%	N/A
Rectifier efficiency	98.9%	93.7%	97.6%	88.8%	94.0%	N/A
System voltage	12 VDC	24 VDC	24 VDC	24 VDC	24 VDC	24 VDC
Overall efficiency	24.4%	44.0% **	24.6%	12.3% ***	28.0%	59.2%

\* For reference only, this is not an induction generator.

\*\* Without retesting, no explanation can be found for this abnormally high efficiency.

\*\*\* Poor efficiency likely caused by an old installation using two equal size capacitors connected instead of C-2C configuration, or a locally made transformer.

### Disadvantages of Induction Generators

#### 1. High Voltage!

*Danger!* Great care should be taken working with the 240 to 800 volts AC that these units generate. It can be lethal at worst, and at the least, it's memorable.

#### 2. Initial Setup

With this system, capacitors must be connected to the motor to supply excitation current, allowing the motor to become a generator. *Danger!* To prevent electrical shock, the excitation capacitors need to have a 1 megaohm, 2 watt discharge resistor connected terminal to terminal.

The connection method calls for "C" amount of capacitance across the phase where the output is taken and "2C" across the other phase (see diagram). As an initial value of capacitance, use 3  $\mu$ F per motor HP for "C" and 6  $\mu$ F per HP on the "2C" phase.

To maximize efficiency, capacitor sizing needs to be done on a trial and error basis. The machine should be

installed in its permanent site or with site conditions duplicated in a test situation. A clip-on ammeter, with a low scale such as 0-6 amps, is ideal for the procedure detailed below. If a clip-on meter is not available, the 10 amp range found in most multimeters will work, but the user will need a lot of patience and care. Each measurement will require shutting down the turbine and opening the circuit to allow connection of the meter for amp measurement.

When the three phases are combined into a single phase wire pair, then the electrical direction of motor rotation must be determined. The capacitors need to be connected between the correct phases for the rotational direction. First connect the motor as shown in the diagram. Carefully measure the current in the ungrounded output wire and note the result of the measurement. Change the 2C capacitor connection point from 3 to 2, leaving 1 connected. Again measure the current in the output wire. If the current is higher than in your first measurement, leave the capacitor in



**The Buena Vista Lodge uses a 1.5 HP motor to generate 370 watts from a three-nozzle pelton wheel.**

this position. If the current is lower than in your first measurement, return the connection to point 3.

The current in each motor lead should be checked for balance. Each leg needs to be within 30 percent of the others. Do not, under any circumstances, let the current exceed the motor nameplate rating for the selected wiring configuration. Most three-phase motors have dual voltage connections. For example, a nameplate rating list may show 2 amps for the 480 volt configuration and 4 amps when connected for 240 volts. So if the motor is wired for 480 volts, the 2 amp plate rating is the maximum allowed per phase even if the generation voltage is only 240 volts.

Capacitor substitution for the initial values will correct phase imbalances if they exist. It is very helpful to have industrial electrical experience for this process, but handy people with a good knowledge of electricity can usually muddle through it. A selection of motor run

**Casa Corcovado Lodge gets 410 watts from 60 gallons per minute at 148 feet of head.**



**415 VAC becomes 24 VDC at Buena Vista's power center, 2,500 feet from the Harris hydro unit.**

capacitors is necessary for maximizing machine output. This is a fairly significant cost outlay—about US\$200—and you will end up with some extra capacitors when you're done.

### 3. Low Generating Efficiency

Thomson and Howe is a company in British Columbia, Canada that did much of the early work on induction hydro generation. They reported efficiencies between 86 and 95 percent for three-phase induction motors used as generators. My experience does not confirm these efficiencies. The highest efficiency I've seen was achieved with a stand-alone system using a 10 HP motor, and that was about 70 percent efficient. It is tempting to assume that the larger HP motors produce higher efficiencies, but additional experimentation is needed. Most motor catalogues will list the efficiency of the product. Generally, the higher efficiency models will also produce an increased efficiency when used as a generator.

The 1-2 HP motors generally used for battery charging systems have produced efficiencies in the 25-35 percent range. This is significantly below the 50-60 percent that a properly installed Ford or ESD generator will produce. But the more efficient low voltage DC units are not practical for transmission distances over 800 feet (244 m) in 48 volt systems. For lower voltages, maximum transmission distance is considerably less. For sites with long distances, the practicality of the high voltage induction generators outweighs the lower efficiency.

### 4. Load Disconnection Runaway Overload Protection

Overload protection should be used on generators run near their output limit. When runaway occurs because of load disconnection, if the capacitors remain connected to the generator, both the voltage and

current will rise. The motor has an information plate that indicates its maximum current per phase. If any of the individual phase currents exceed the nameplate maximum current at runaway, then controls need to be installed. The controls disconnect the capacitors from the motor, allowing it to freewheel.

When the capacitors are disconnected, the generator voltage will collapse. This control circuitry can take several forms. The simplest is a 600 V fuse in series with each of the two capacitors in the C and 2C format (see diagram). This fuse should be no larger than the rating of maximum current on the motor plate. Miniature magnetic circuit breakers can be used in place of the fuses if loss of load is a common occurrence. With an additional level of control circuitry, the capacitors can be disconnected from the motor if either a high or low voltage occurs on the output. This same circuitry can actuate water valves that can shut off water flow to the turbine.

AC motor run capacitors with a voltage rating that exceeds the runaway voltage should be used. Newark Electronics has 660 VAC motor run capacitors that will withstand the peak runaway voltage on all but the 575 V induction generators.

When capacitors are not available with the correct voltage rating, lower voltage units can be used in series. With this configuration, the voltage rating of the capacitors will be additive. The capacitance is calculated with the formula  $1/C_{total} = 1/C1 + 1/C2 + 1/C3$ . Example: Two 440 V, 10  $\mu$ F capacitors in series would then be 880 V, 5  $\mu$ F.

##### 5. Large Inductive Loads Need Power Factor Correction

Stand-alone induction generators have difficulty running inductive loads such as motors. A stand-alone induction generator directly runs the loads and does not use batteries or an inverter. These systems require more sophisticated electronics to operate, in the form of a load controller with ballast resistors, which hold the voltage and frequency near 60 Hz 120/240 volts. The motor load inductance reacts with the generator's excitation capacitors, causing the voltage to fall and the frequency of generation to rise. If too large an inductive load is connected, it will cause the generator to lose excitation. To correct this problem, motors run directly



**Joel Stewart and Belan Momene are building a hydro-powered lodge. Currently, their system provides 15 KWH per day.**

on stand-alone induction generators should be power factor corrected with both start and run capacitance.

##### 6. Generator May Lose Residual Magnetism

Loss of residual magnetism occurs when the generator is rapidly shut down with a load connected, loses excitation because of an overload, or more often from running down (blocked intake water filter) with a load on. Residual magnetism is present in the iron core of the rotor. This allows the motor and capacitors to begin generation, which subsequently builds up to its normal voltage level.

If this magnetism is lost, it can be restored by connecting a simple 9 V radio battery between any two of the motor leads for a couple of seconds. The iron core material used in high efficiency motors holds less residual magnetism, so these motors are more susceptible to this minor problem.

**Joel and Belan's turbine receives 185 gpm with 65 feet of head. The 2 HP generator delivers 630 W at 334 VAC.**





### Experience Is The Best Teacher

Sistemas de Energia Eficientes is the company I operated in Costa Rica for eight years. We installed six induction generating systems there in the last five years, and maintained an additional unit. See the system comparison table for details on these systems.

Experience is the name we give to our mistakes. The good news is that all of the systems are still working and the clients are very happy with them. The bad news is that it took making some mistakes to gain lots of experience. These are some of the lessons we've learned through the school of hard knocks:

- The jungles of the third world are not the place for product experimentation. The same applies, to a lesser degree, to field conditions in developed countries.
- Standard transformers and water valve solenoids work best at 60 Hz or above. The net head, turbine type, wheel diameter, and motor nameplate rpm need to be selected to allow the generator frequency to be within 55-75 Hz.
- Keep it simple—Murphy's Law is always enforced eventually. Use the simplest protection controls that will do the job, which usually means 600 volt fuses on the two capacitors. The operator of the plant must understand what occurs at runaway and why the fuses blow, and needs to have spares on site. If the phase current exceeds the nameplate value during loss of load or runaway, the motor is at risk of burning up. This is when the controls need to be used, a smaller turbine jet installed, or a larger motor selected.
- The motor generation voltage is determined by a chain of system components. The links in this chain are battery voltage, rectifier type and configuration, the main step-down transformer, and to a lesser extent, the resistance losses in the transmission line from the generator to the transformer. These must be carefully selected or system frequency and voltage may be drastically different than the design value. Low generation voltage and frequency will cause problems. If this happens, transformers will not operate as efficiently and water valve solenoids may not fully actuate, resulting in control transformer failure.
- Don't skimp on the penstock size; larger is always better. Black poly pipe, at least the pipe manufactured in Central America, has very high frictional losses. For this reason, I do not recommend it for hydro installations. PVC works very well but contains vinyl chloride, which is not at all good environmentally. Does anyone out there have experience with ABS and a knowledge of its toxicity?
- Shottky rectifiers should not be used with these systems. They cannot withstand the runaway voltage present if someone removes a battery cable while the turbine is generating.

### Step-Down Transformers

High voltage from the generator needs to be lowered to the nominal battery voltage. A single-phase transformer is used, but it must be carefully selected for efficiency and proper voltage rating. Custom made high efficiency transformers are usually used on these systems. GE does make a production model with 480/240 primary and 48/24 secondary. They come in 0.75 and 1 KVA sizes retailing for US\$294 and \$370. These would function for 1 1/2 and 2 HP motors of 575 and 480 volts. The downside of production models is that they do not have multiple taps on the primary, which assist in maximizing output efficiency.

Generally, a motor can be used as a generator at voltages from 50 to 85 percent of the motor nameplate rating. For example, a 1 1/2 HP, 240/480 V, 1200 rpm motor is selected and connected as 480 volts. A custom transformer that would match this motor could be specified as 0.75 KVA, with primary voltages of 240, 280, 320, 360, and 400, and secondary voltages of 24 or 48 (depending on battery bank voltage), center tapped. If the GE production model is used, the 240 volt primary must be used. But custom wound, high quality transformers can be obtained at a cost very similar to the GE production models.

### Site Evaluation

A thorough and accurate site evaluation should be the first step to any hydroelectric project. Everything you find on the subject will basically get you two numbers: *net head* and *flow*. It is very important that the analysis is accurately done, since the whole hydro project is designed around these numbers.

### Step by Step Procedures

1. Determine whether or not there are legal or social obstacles to using the stream water. Get the permits or understand the risk.
2. Accurately determine the gross and net head available, and the water flow. An average yearly flow and minimum flow will be sufficient in most cases.
3. Calculate net stream potential using this formula:

$$P = H \times F \times E \div 100$$

Where P is power in watts (stream watts net), H is gross head in meters, F is flow in cubic meters per second, and E is overall efficiency.

Overall efficiency is expressed as a decimal, and includes penstock, turbine, generator, wire, transformer, and rectifier losses. A number that can be used for the efficiency of small stand-alone induction systems of less than 5 KW is 0.4 (40%). For battery charging configurations, 0.3 (30%) is appropriate.

4. Determine load in both KWH per day and peak KW. If the potential of the stream is equal to or greater than the peak KW needed, consider a stand-alone installation. A battery charging system is generally less than half the cost of a stand-alone system for the same peak KW. A properly installed stand-alone system is more reliable because it does not use batteries or inverters. It will also produce considerable excess power that can be used for water heating, etc.

5. If the turbine end of the penstock (pipe from water intake to turbine) is located farther than 500 feet (152 m) from the area where the power needs to be used, then an induction generator should be considered. If an induction machine is applicable, select the motor rpm and HP that is appropriate for the hydro resource available and the load needed.

See the rpm selection chart for induction motors used in battery charging systems. It assumes that the turbine runner diameter is four inches (10 cm). Try to stay as near as possible to the "ideal" shown in the chart. These ranges need to be experimentally verified under laboratory conditions, especially the minimums and maximums. Is any reader out there looking for a university thesis project?

**German Llano's filter tank, at the top of 55 feet of head, provides a clean 73 gallons per minute.**



**Motor RPM Selection Table**

Motor rpm	Head in Meters		
	Minimum	Ideal	Maximum
3500	60	80	150
1800	20	40	80
1200	12	20	40
900	6	10	20

6. To select the horsepower of the motor using the average stream flow, determine the potential of the stream in watts. Next, divide this number by 745 watts, which will give you theoretical motor HP. But the motor will not produce as a generator what it consumes as a motor. To derate a small motor under 3 HP used as a generator, divide the resultant motor HP rating by 0.75. This will give you the actual motor HP needed. Here it is in one formula:

$$HP = P \div 745 \div 0.75$$

Where HP is the necessary rating of the motor in horsepower, and P is stream watts net.

**Additional Technology Development In Process**

I am now experimenting with the excitation and synchronization of the induction generator to the output of Trace sine wave and modified sine wave inverters. This has the potential to decrease the number of components required and the associated costs, while at the same time increasing the efficiency of the generation process.

**Resources**

Technical information on selection, purchase, setup, installation, and maintenance of induction generators is difficult to obtain. Very few publications exist describing this useful technology. The exception is one excellent book, still in print, from IT Publications in England,

**Llano's ES&D 28 volt DC alternator acted as the control group in the comparison of AC induction generators.**





*Motors as Generators for Micro-Hydro Power.* In the Access section, you'll also find information on one company in Canada and two in the U.S. which offer assistance and sell equipment.

There are many books available on the subject of hydro site analysis. I highly recommend *Micro-Hydropower Sourcebook* and *Micro-Hydro Design Manual*. Both of these books are references on most facets of a hydro project and are well worth the expenditure. Also, see articles that deal with this topic in *HP42*, page 34, and *HP44*, page 24.

An excellent and accurate shareware computer program that is very easy to use is available for hydro site analysis. Preferred Energy Resources can supply this program for \$10, which covers copying and mailing costs.

### Care and Attention

I would like to advise care and attention to detail in all aspects of the design of microhydro installations, especially the civil works. A properly designed and built project will last a lifetime. Unfortunately, there are many installations abandoned shortly after they are built because of improper engineering or construction. So do it right, and if you have questions, seek professional help.

If the site parameters and budget lend themselves to a battery charging hydro but the water source is too far away for a DC turbine, then a high voltage induction generator should be able to satisfy the need. If properly engineered and installed, it will provide many years of clean reliable electricity at a fraction of the cost of other renewable energy options.

### Access

Induction motors, turbines, transformers, rectifiers, and technical assistance:

Bill Haveland, Preferred Energy Resources L.L.C. (formerly Sistemas de Energia Eficientes SEESA), 3032 County Road 7, Grand Marais, MN 55604 218-387-2160 • Fax: 218-387-2173 bhaveland@boreal.org

Alternative Energy Engineering, PO Box 339, Redway, CA 95560 • 800-777-6609 or 707-923-2277 Fax: 800-777-6648 or 707-923-3009 jay@alt-energy.com • www.alt-energy.com

Stand-alone turbine manufacturer, using synchronous generators: Canyon Industries, 5346 Mosquito Lake Rd., Deming, WA 98244 • 360-592-5552 Fax: 360-592-2235 • CIturbine@aol.com www.canyonindustriesinc.com

Stand-alone induction experts with the most experience in North America: Thomson and Howe, Site 17, Box 2, S.S. 1, Kimberley, BC, Canada V1A 2Y3 250-427-4326 • Fax: 250-427-3577 thes@cyberlink.bc.ca • www.smallhydropower.com

*Micro-Hydropower Sourcebook*, 1999. Allen Inversin, NRECA. US\$26 postpaid from NRECA International Foundation, Mail Code IPD9-202, 4301 Wilson Boulevard, Arlington, VA 22203-1860 703-907-5637 • Fax: 703-907-5532 allen.inversin@nreca.org • www.nreca.org

*Micro-Hydro Design Manual*, 1993. Adam Harvey, IT Publications. \$55 from Stylus Publishing L.L.C., PO Box 605, Herndon, VA 20172 • 703-661-1581 Fax: 703-661-1501 • styluspub@aol.com

*Motors as Generators For Micro-Hydro Power*, Nigel Smith, IT Publications. \$12 from Stylus Publishing L.L.C. (see above).



## Specializing in **COMPLETE** systems design

*Solar Electric, Heating,  
Water, & Appliances  
Including complete CAD  
design services*

We can supply everything you need to be off-grid...  
inverters to modules to batteries, including your kitchen stove.

All the best brands...  
**TRACE • KYOCERA**  
**APT • BUDERUS**  
**THERMOMAX**  
**WATTSUN**  
**SOLARJACK • IBE**  
**PEERLESS-PREMIER**



Authorized  
GOLDEN GENESIS  
Dealer



P.O. Box 340, 262 Badger Road  
Ennis, MT 59729

**Ph 406-682-5646 • Fx 406-682-5644**

